

Philco



TV PH55E30DSGW

<http://treinamento.britania.com.br>

0800-415300

VISTA EXPLODIDA

Acesse a LISTA BÁSICA em www.telecontrol.com.br e consulte os códigos das peças pela referência.

PRODUTO	CÓDIGO	TENSÃO	PADRÃO DE N° SÉRIE
TV PH 55E30DSGW	099553012ATX	BIV	0 00 00000 00 T 203 X
(X) - O último algarismo nas colunas "Código" e "Padrão N° Série" significa a versão do aparelho.			

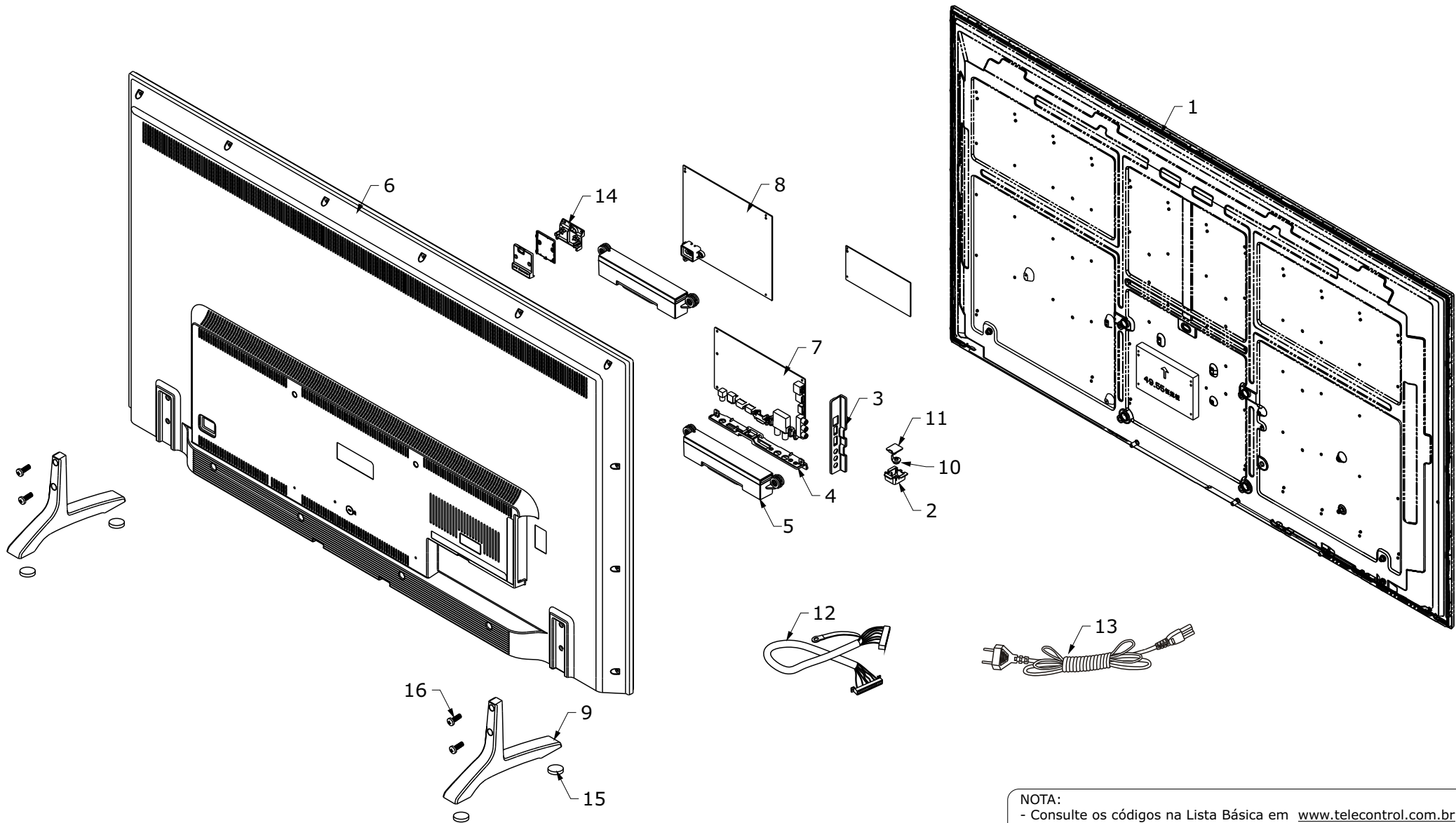

NOTA:
 - Consulte os códigos na Lista Básica em www.telecontrol.com.br
 - Somente os itens que possuem códigos serão fornecidos.
 - Em caso de dúvidas acessar <http://treinamento.britania.com.br> ou entrar em contato com o Suporte Técnico.
 - Este documento está sujeito a alterações sem aviso prévio

Inverter controller

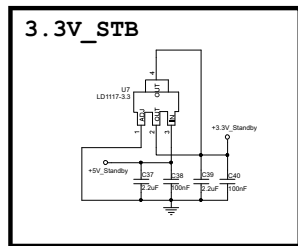
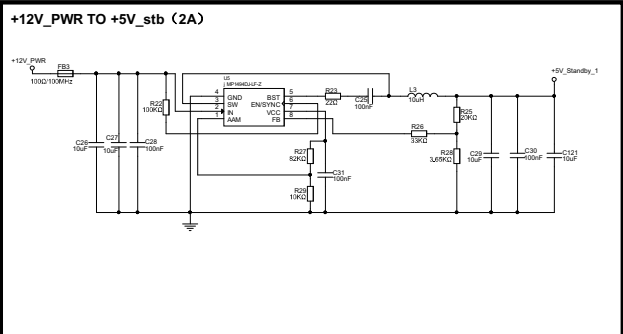
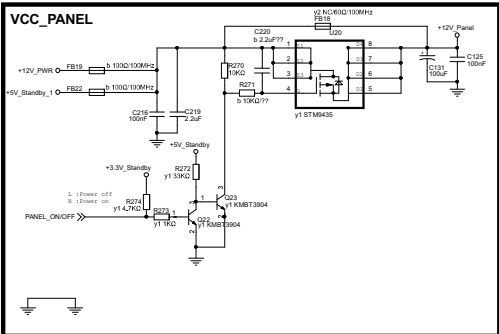
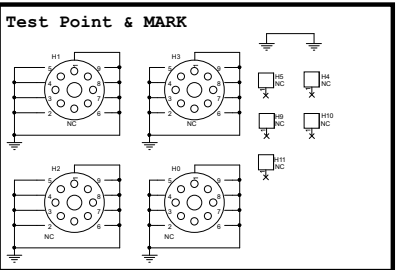
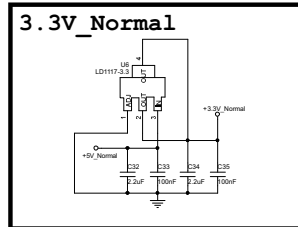
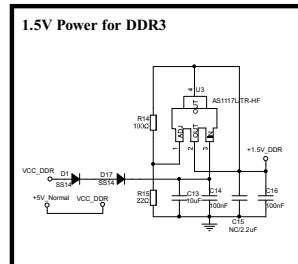
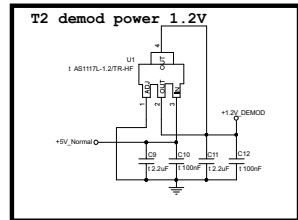
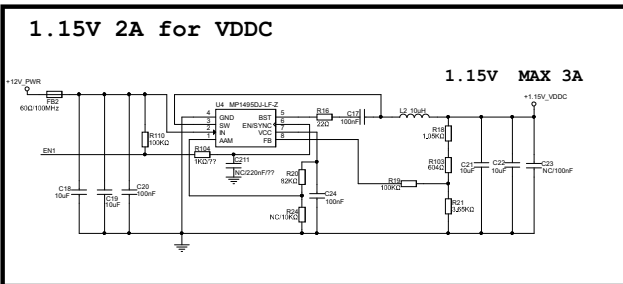
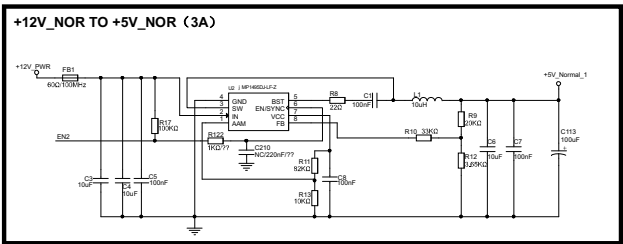
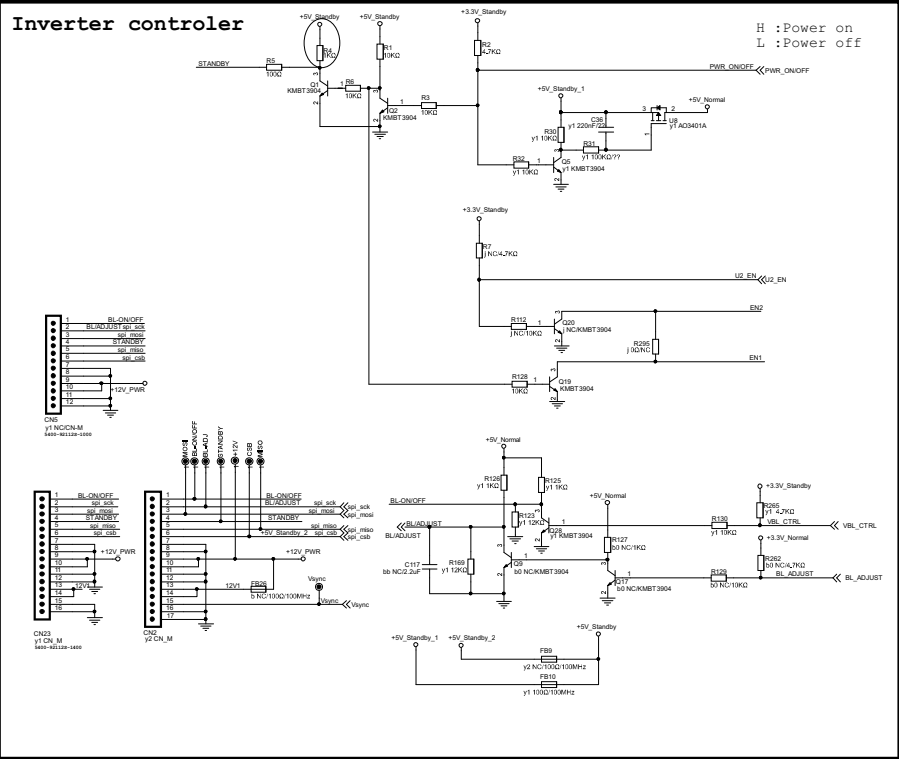

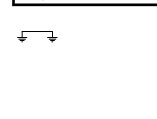
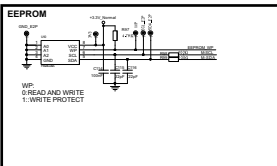
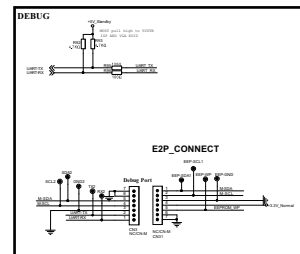
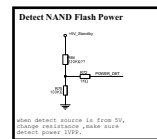
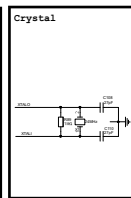
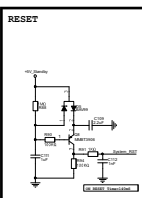
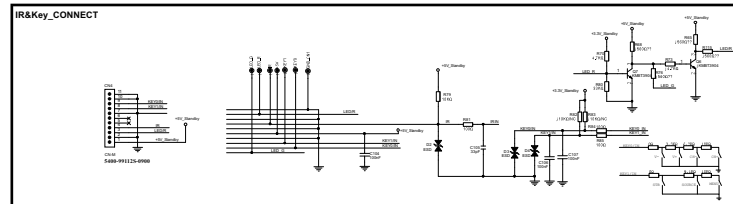
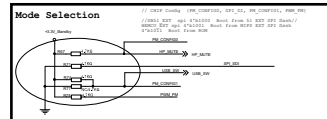
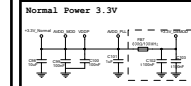
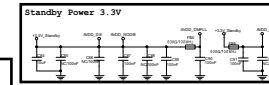
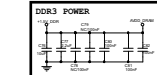
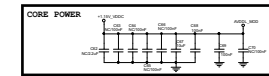
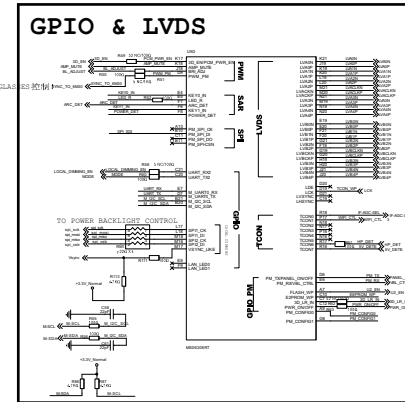
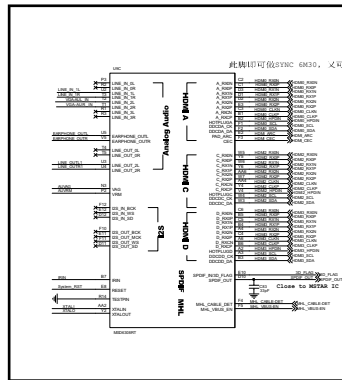
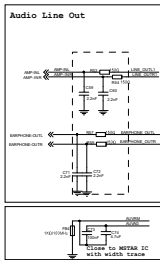
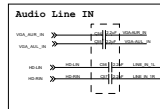
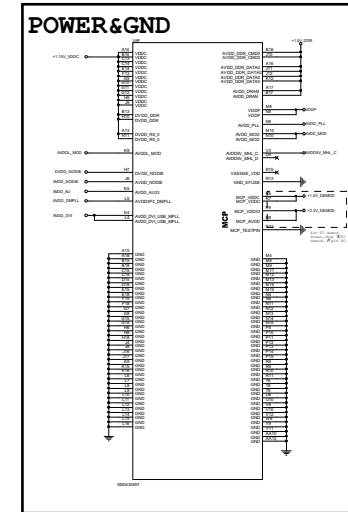
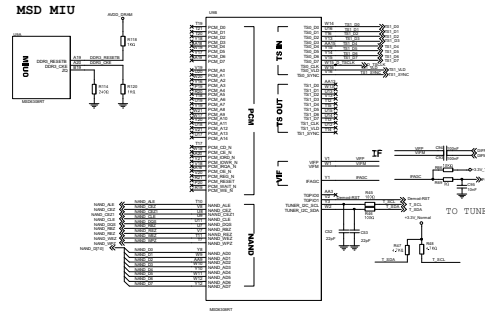
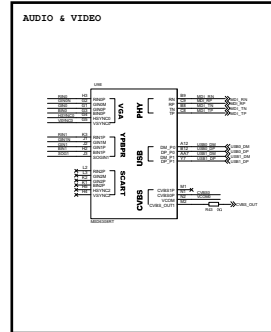
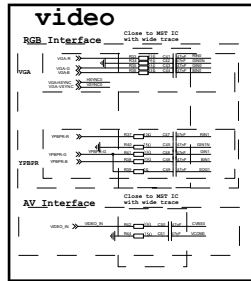

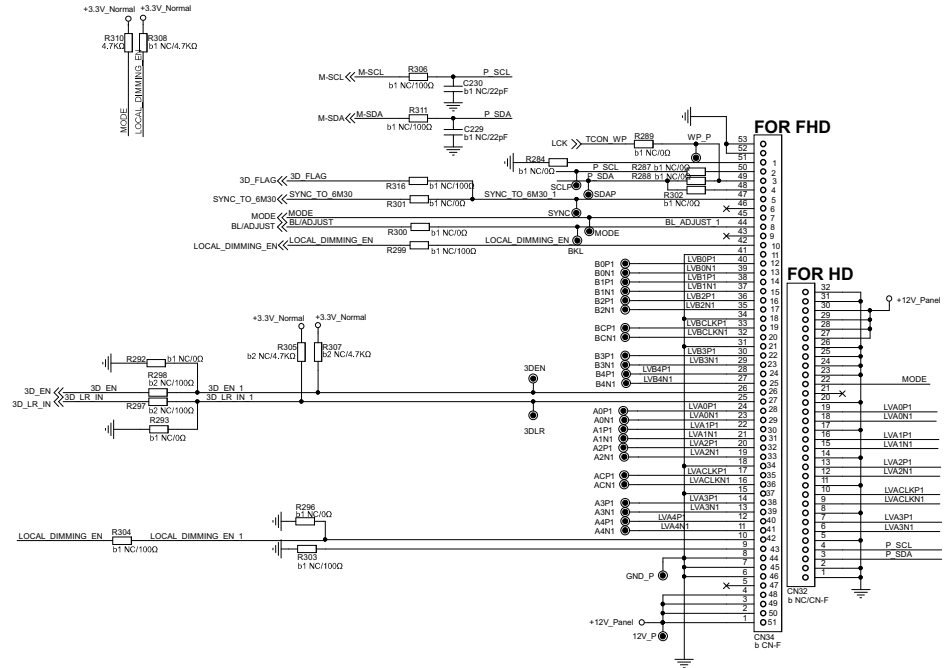
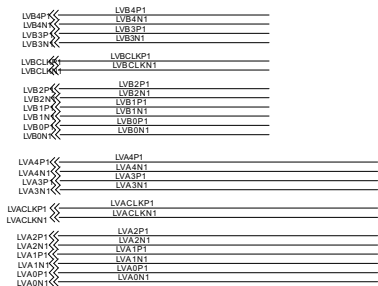
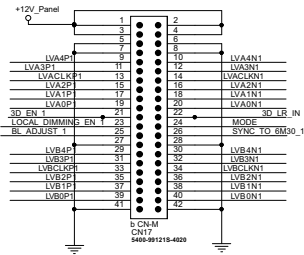
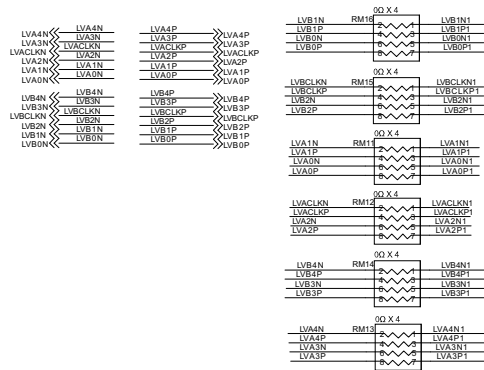

FOR FHD

FOR HD

HDMI 1 ARC

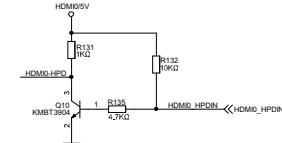
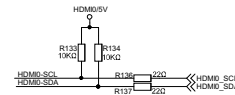
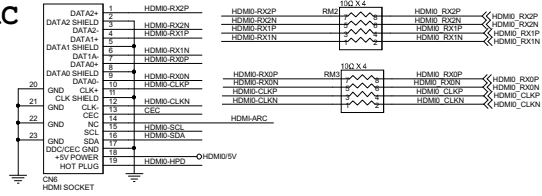

MHL HDMI 2

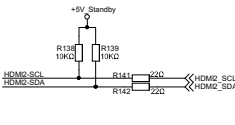
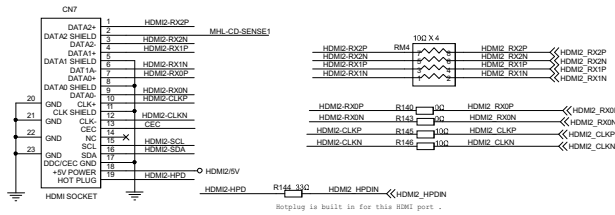

YPBPR

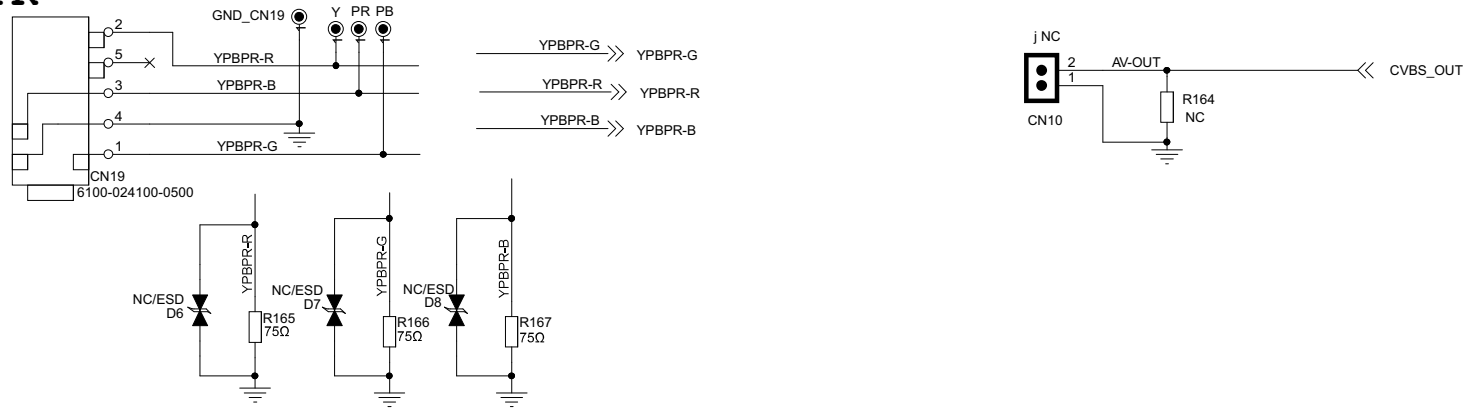

AV INPUT

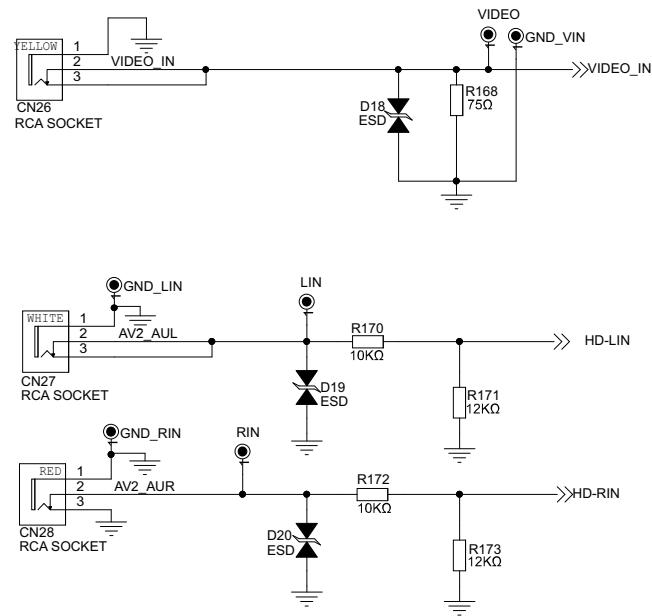

SPDIF OUT

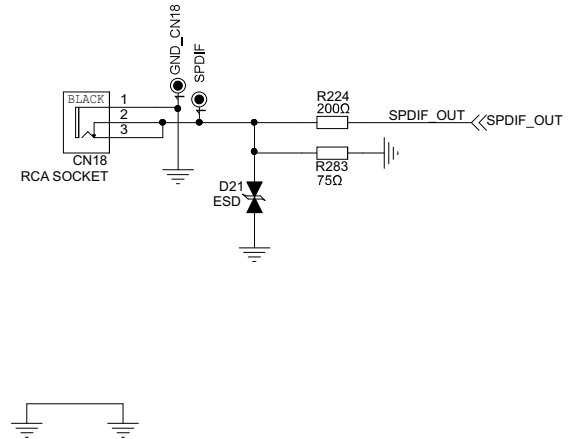

VGA

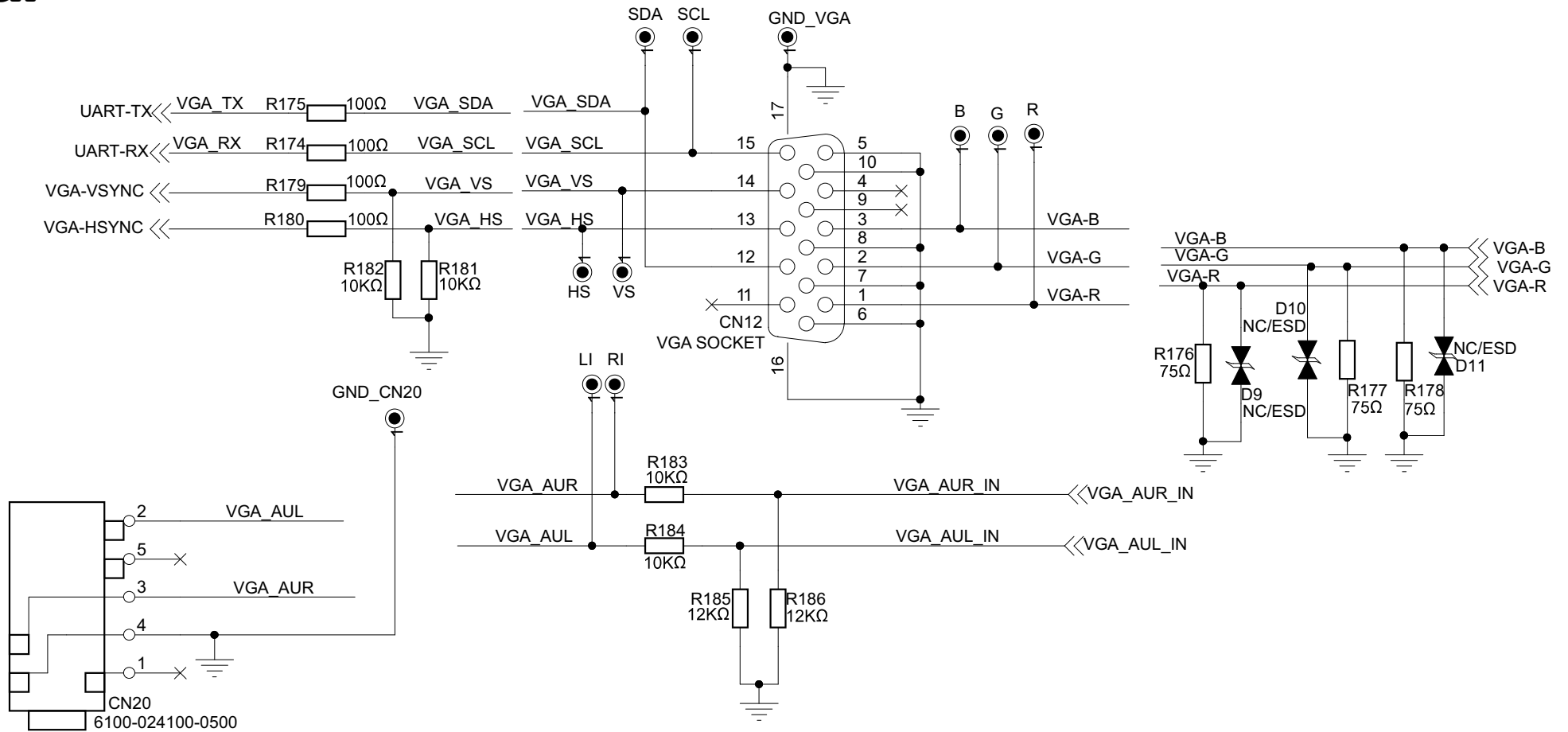

USB2.0 INTERFACE

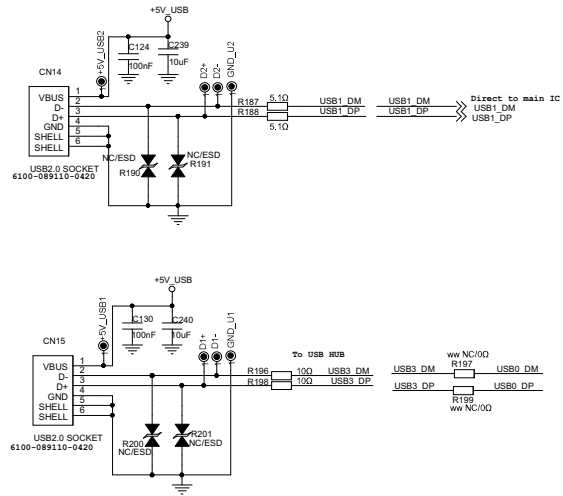

USB POWER

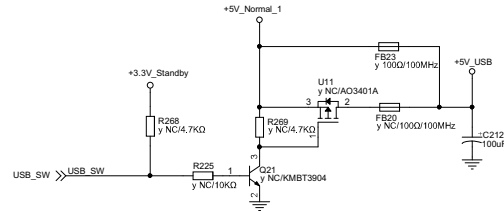

USB HUB

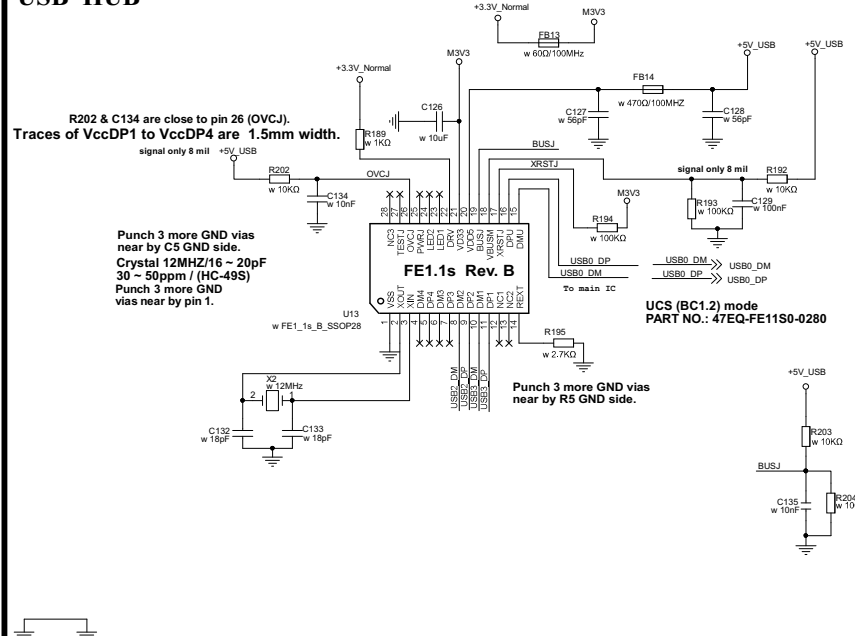

MUTE CONTROL

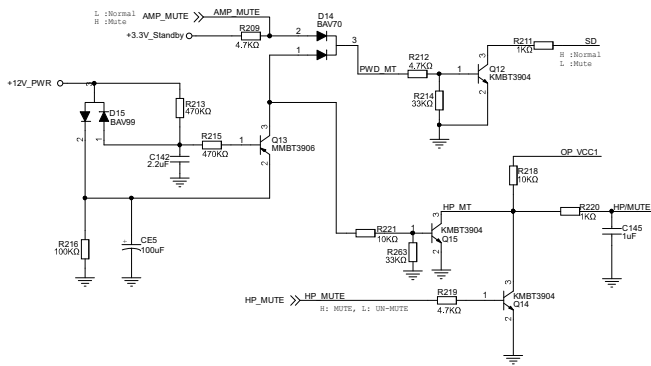

EARPHONE/LINE OUT

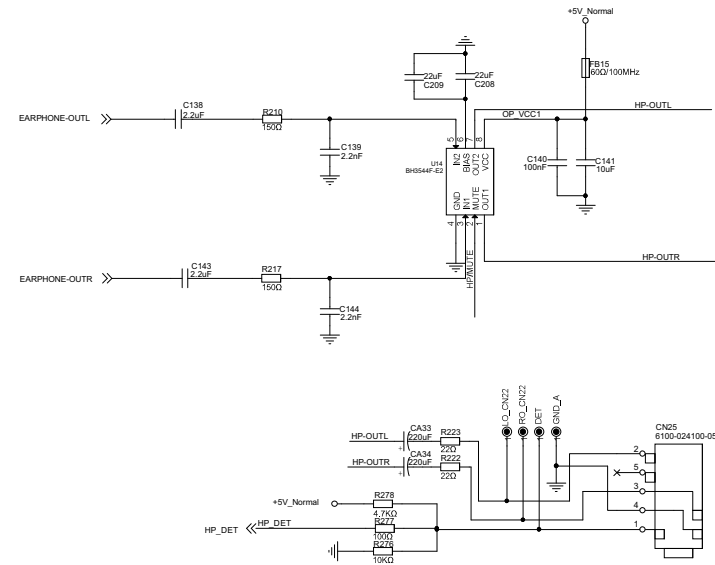

AUDIO AMP

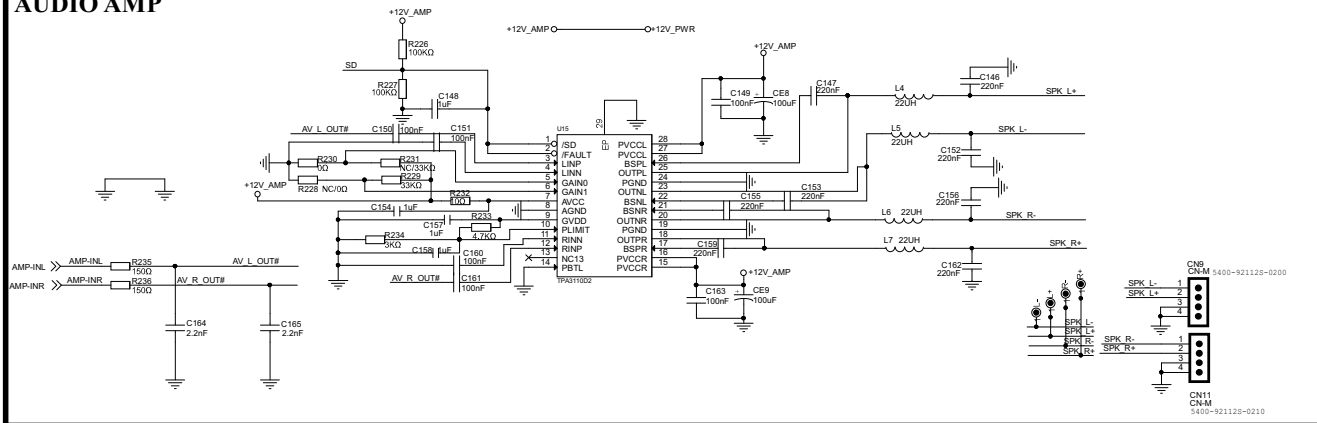

NAND FLASH

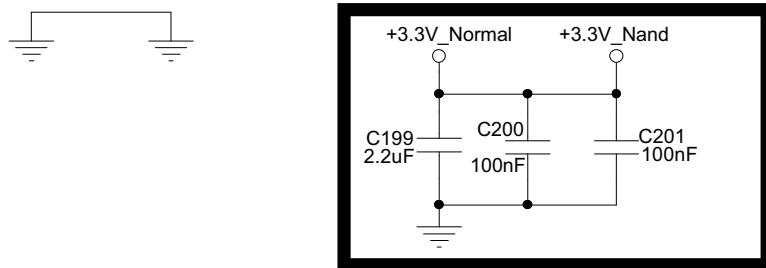
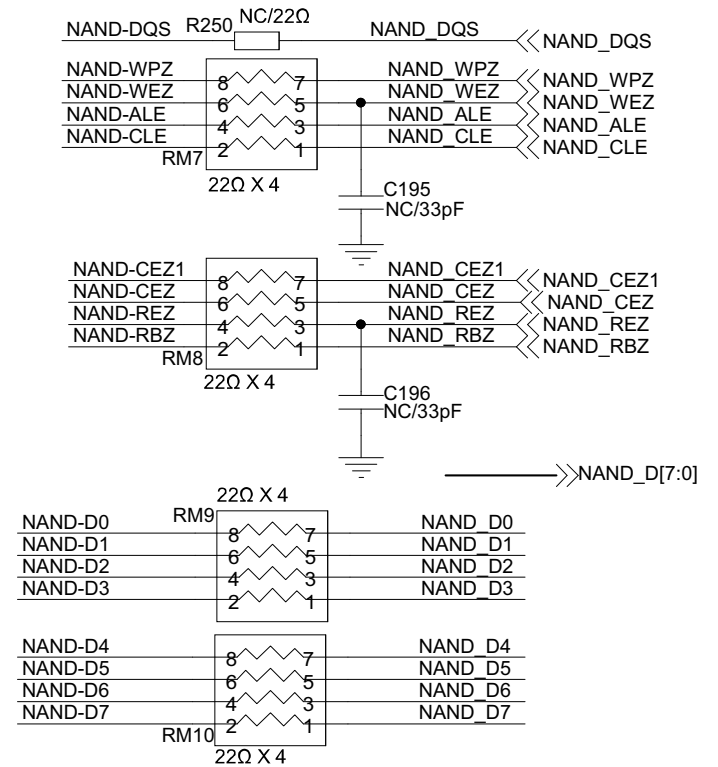
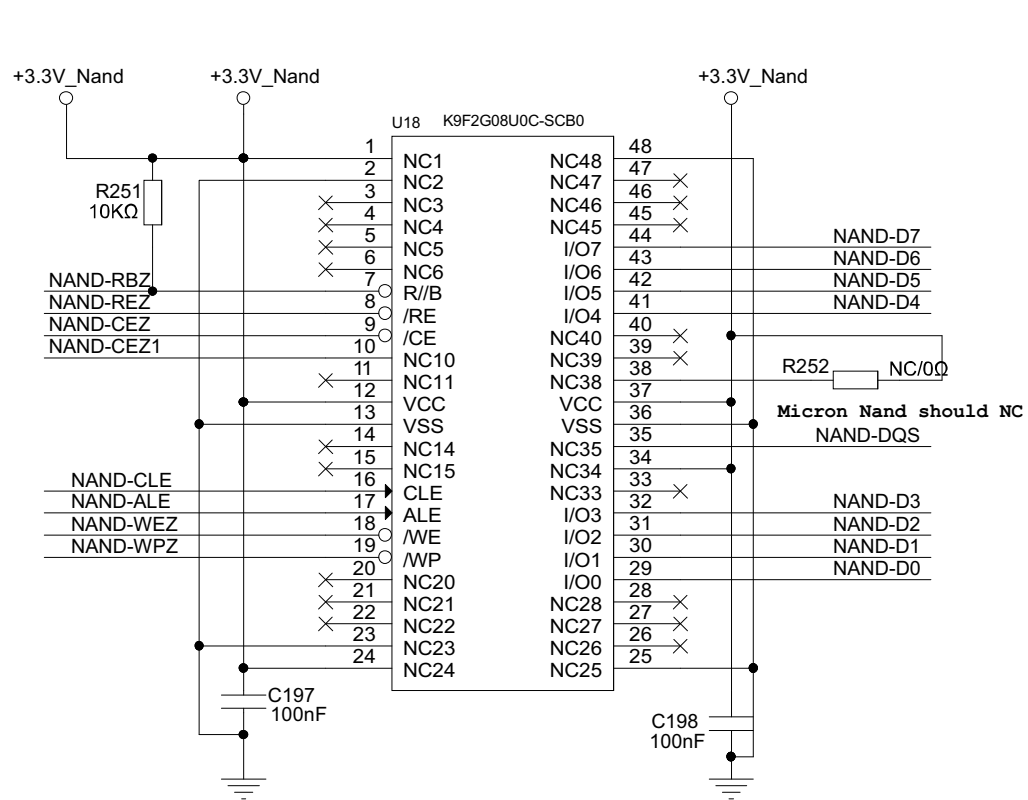

NAND Power

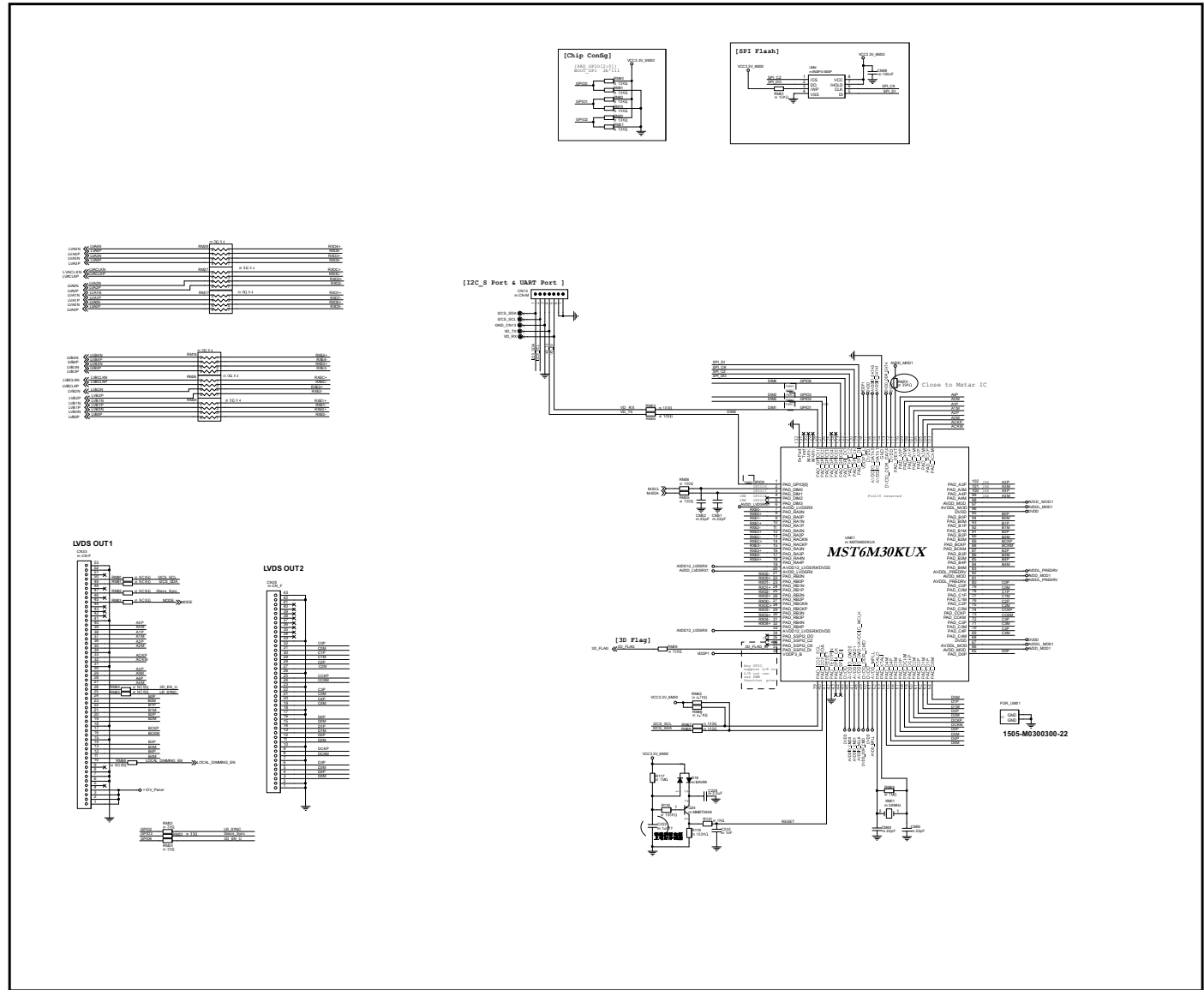
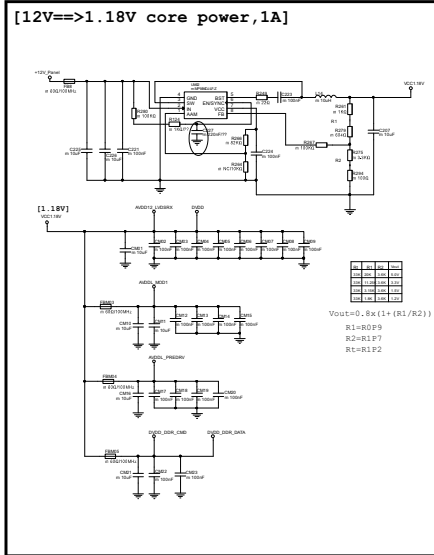
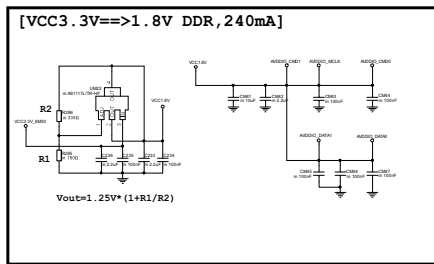
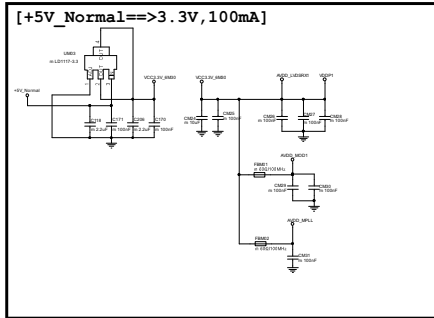

Connector

