

Bang&Olufsen

Beomaster 6000

TYPE 2251, 2252, 2253, 2254

Beomaster Terminal

TYPE 2035

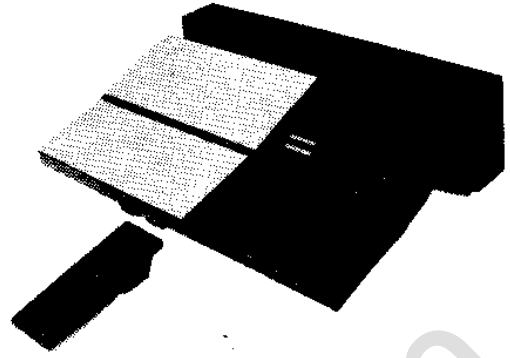

BeoCollectors.com



CONTENTS

Circuit Diagrams	1
Diagram 1	1-3
Diagram 2	1-4
Diagram 3	1-5
Diagram 4	1-6
Explanation to diagram	1-2
Measuring conditions	1-2
Adjustment of no-signal-current	1-2
Function tables	1-6
Survey of display pin connections	1-6
Drawing of PC9 (Microcomputer)	1-7
Block diagram for diagram 3	1-8
Survey of Semi-conductors	2
List of transistors	2-1
List of IC's	2-2
List of diodes and displays	2-3
List of Electrical Parts	3
List of Mechanical Parts	4
Upper chassis	4-2
Lower chassis	4-3
Rear chassis	4-6
Microcomputer PC	4-7
Beomaster Terminal	4-8
Parts not shown	4-9
Survey of packings for module transport	4-9
Guide to Adjustments	5
No-load current	5-1
Offset output amplifier	5-1
Tuning voltage	5-1
Tuner and IF-section	5-2
FM-AF output	5-3
AGC	5-3
Signal strength indicator	5-3
Opening of stereo decoder	5-3
Stereo decoder	5-3
FM light balance	5-4
Volume control	5-5
Reset	5-5
Electrical Description	6
Silent tuning	6-1
Tuning and AFC	6-2
AFC	6-2
Fault switch	6-3
FM frequency counter	6-4
Reset	6-5
µC power back-up	6-6
Time-base for µC	6-6
Adjustment of volume control	6-7
V \wedge adjustment	6-8
Dismantling	7
Technical specifications	8
Insulation test	9
Final testing	10
Service tips	11
Dial drive for volume	11-1
Repairs of volume dial	11-1
Dial drive for FM	11-1
Replacement of 9TR102/202	11-1
Replacement of power supply transformers	11-1
Survey of mounting of wires on power supply transformers	11-1
Survey of wires	11-3

2	Microcomputer diagr. 2-3
3	Tonecontrol and Switch diagr. 1-2-3
4	FM-Tuning diagr. 1
5	Motor diagr. 2-3
6	Motor Control diagr. 1-3
7	Risa Amp. diagr. 2
8	FM diagr. 1
9	Output Amp. diagr. 2
11	Fuse and Relay diagr. 3
12	Remote Transmitter diagr. 4
13	Remote Keyboard diagr. 4
14	Remote Receiver diagr. 4
16	Power Supply diagr. 3
17	Socket Panel diagr. 1-2

EXPLANATION TO DIAGRAM

Because of the large number of internal connections in the set the wire connections have been gathered into «bundles» in the diagram. The individual wire is provided with codes indicating where they lead to.

INTERNAL CONNECTION ON A DIAGRAM PAGE

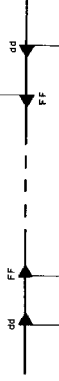

indicating by two identical letters (capital or small).

CONNECTION TO ANOTHER DIAGRAM PAGE

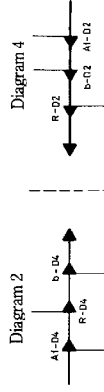

indicated by a letter (capital or small) and a diagram (D) number or by a small and a capital letter together with a diagram (D) number.

GROUND SYMBOLS

Two different ground symbols are used in the set.

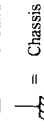
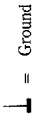

CO-ORDINATE NUMBERS

The biggest PC boards are provided with co-ordinate systems. The components on these PC boards are provided with a co-ordinate number on the diagram (smaller printing type than the position numbers) indicating in which co-ordinate they are placed on the PC board.

MEASURING CONDITIONS

All DC voltages are measured relative to ground with voltmeter (inner resistance 10 Mohms).

DC voltages are stated in volts (V), ex.: 0.7 V and are measured in position P at 104 MHz without signal and volume in step 0.

Oscillograms in the remote control receiver are measured with a signal transmitted from the control module at a distance of approx. 0.5 m.

Signal paths are shown for FM, remote control, and for AF right channel. Mechanical switches are shown in neutral position.

ADJUSTMENT OF NO-SIGNAL-CURRENT

Adjust no-signal-current with receiver cold and volume control turned down. **SPEAKERS MUST NOT BE CONNECTED.**
With 9R134 (9R234) adjust to 22 mV DC measured across 9R143 and 9R144, TP100/TP101 (9R243 and 9R244, TP200/TP201), or adjust to 50 mA in collector of 9IC103 (9IC203).

Symbol for safety resistors

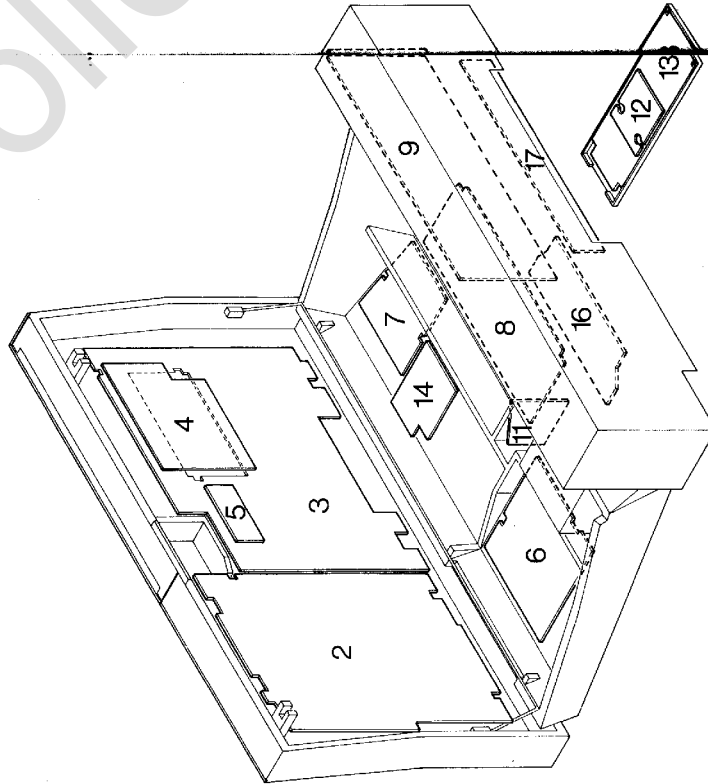

Beomaster 6000
TYPE 2251, 2252, 2253, 2254
Beomaster Terminal
TYPE 2035

DIAGRAM 1

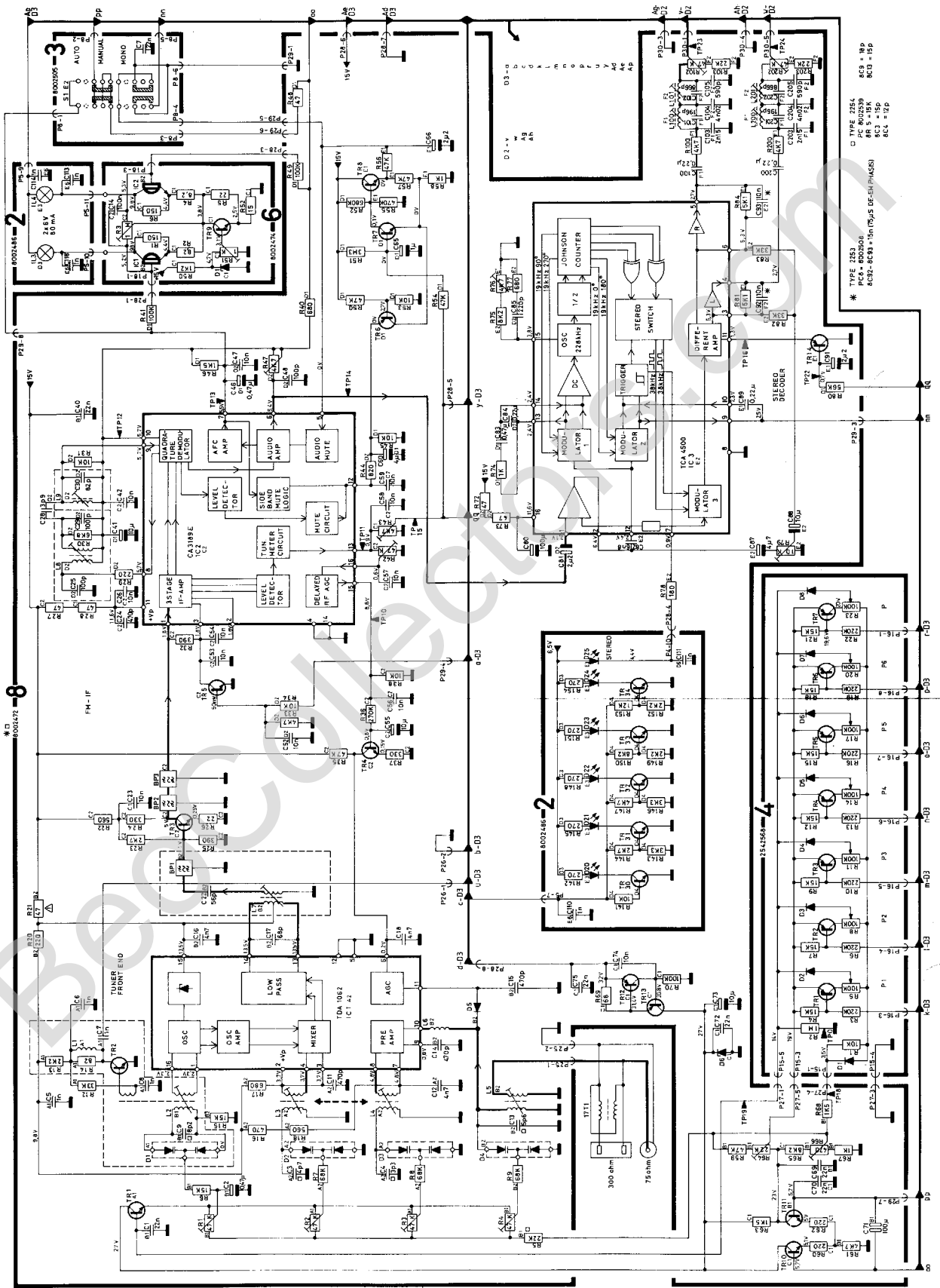

DIAGRAM 2

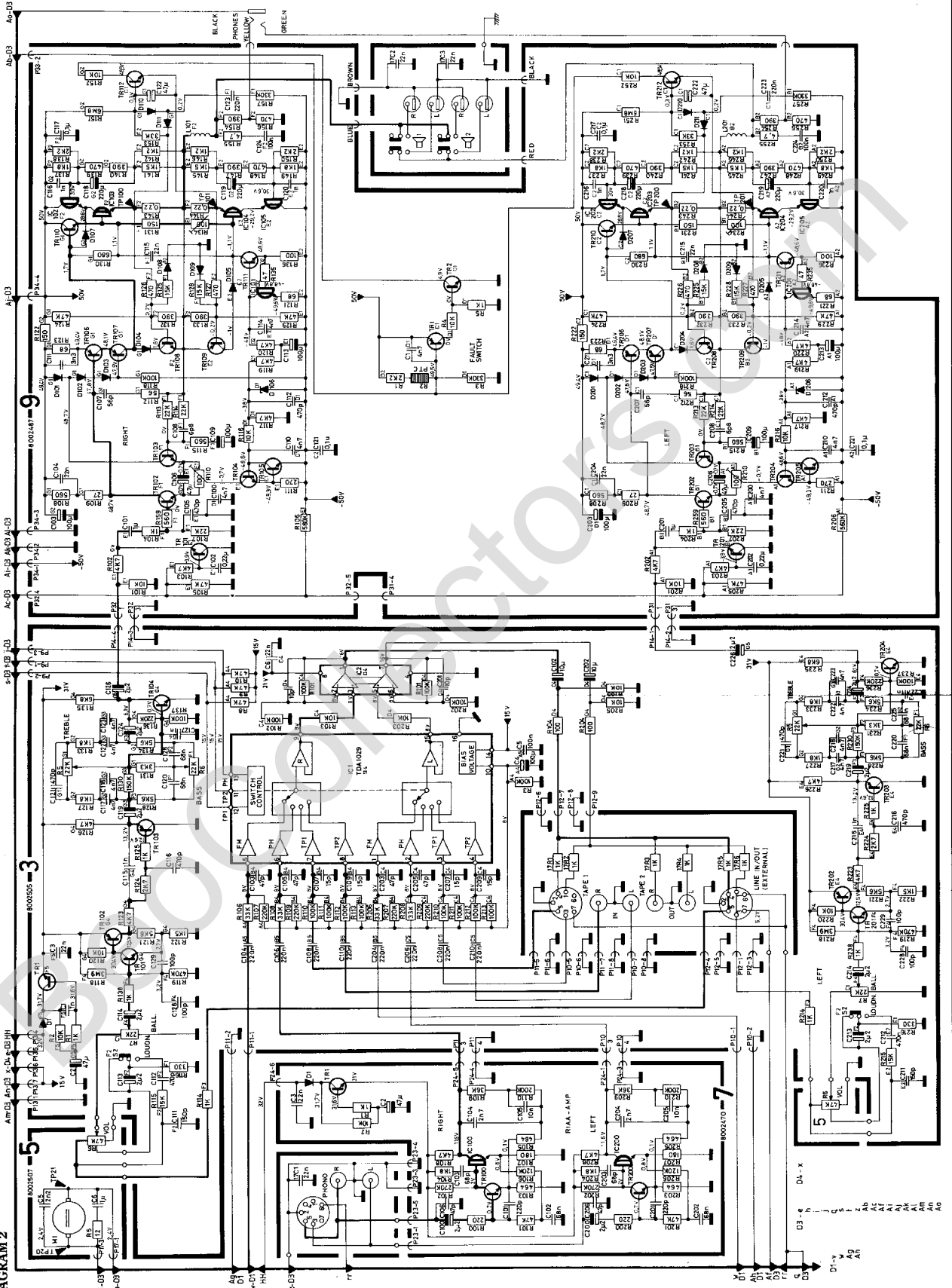
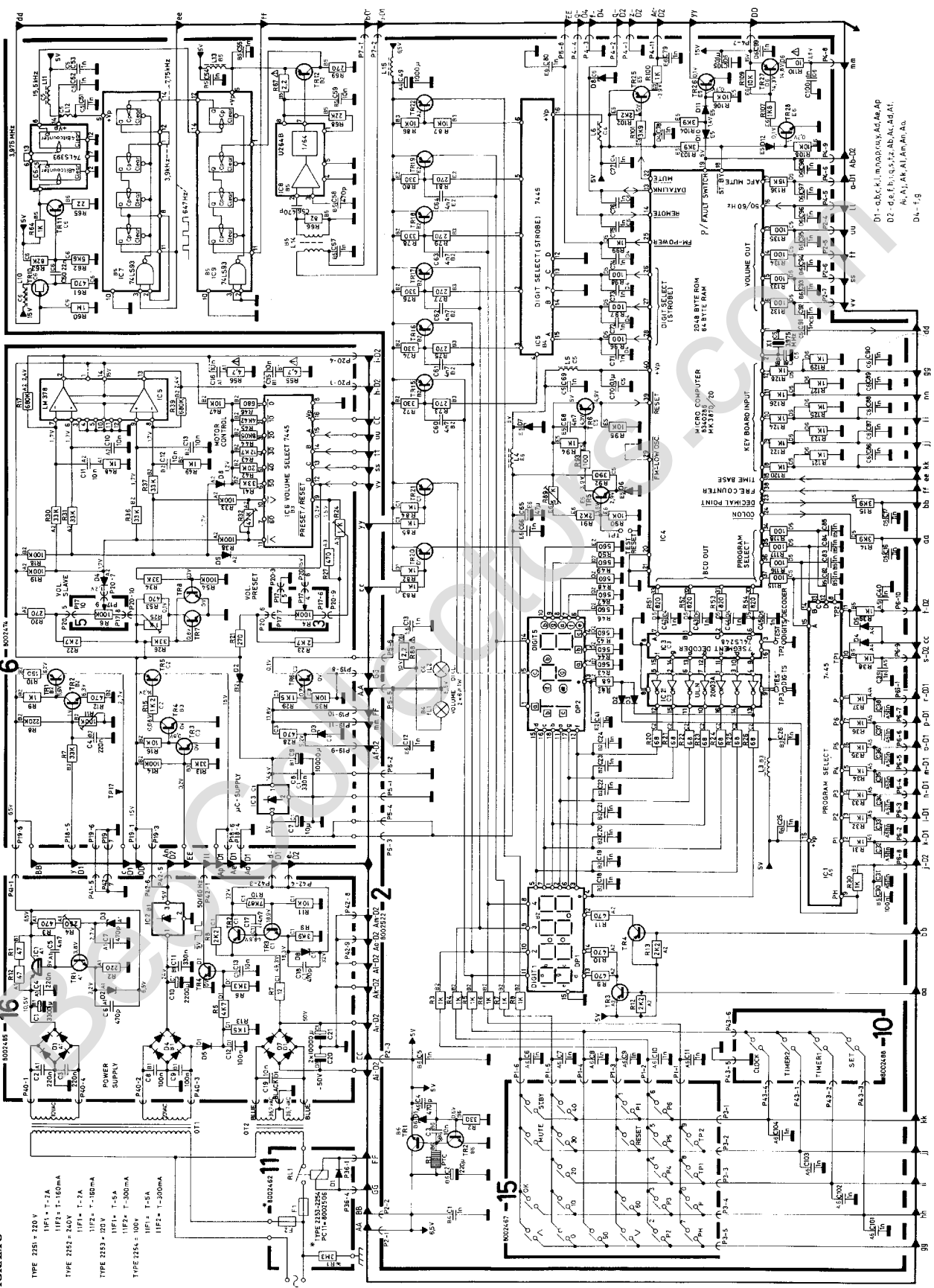

DIAGRAM 3



- TYPE 2251 - T-20V
- 11F1 - T-2A
- 11F2 - T-160mA
- TYPE 2252 - 240V
- 11F1 - T-2A
- 11F2 - T-160mA
- TYPE 2253 - 120V
- 11F1 - T-2A
- 11F2 - T-300mA
- TYPE 2274 - 100V
- 11F1 - T-2A
- 11F2 - T-300mA

D1 - 03C.K.I. 10000044, AG, AM, AP
 D2 - 03 F.B. 16512 AB, AC, AD, AE, AF
 A1, A2, A3, A4, A5, A6, A7, A8, A9, A10

PC2, 8002522 Microcomputer

PC-pladen er vist fra komponentisiden
The PC board is shown from the component side
Printplatte von der Bauteilseite angesehen
Le circuit imprimé est indiqué du côté des composants.

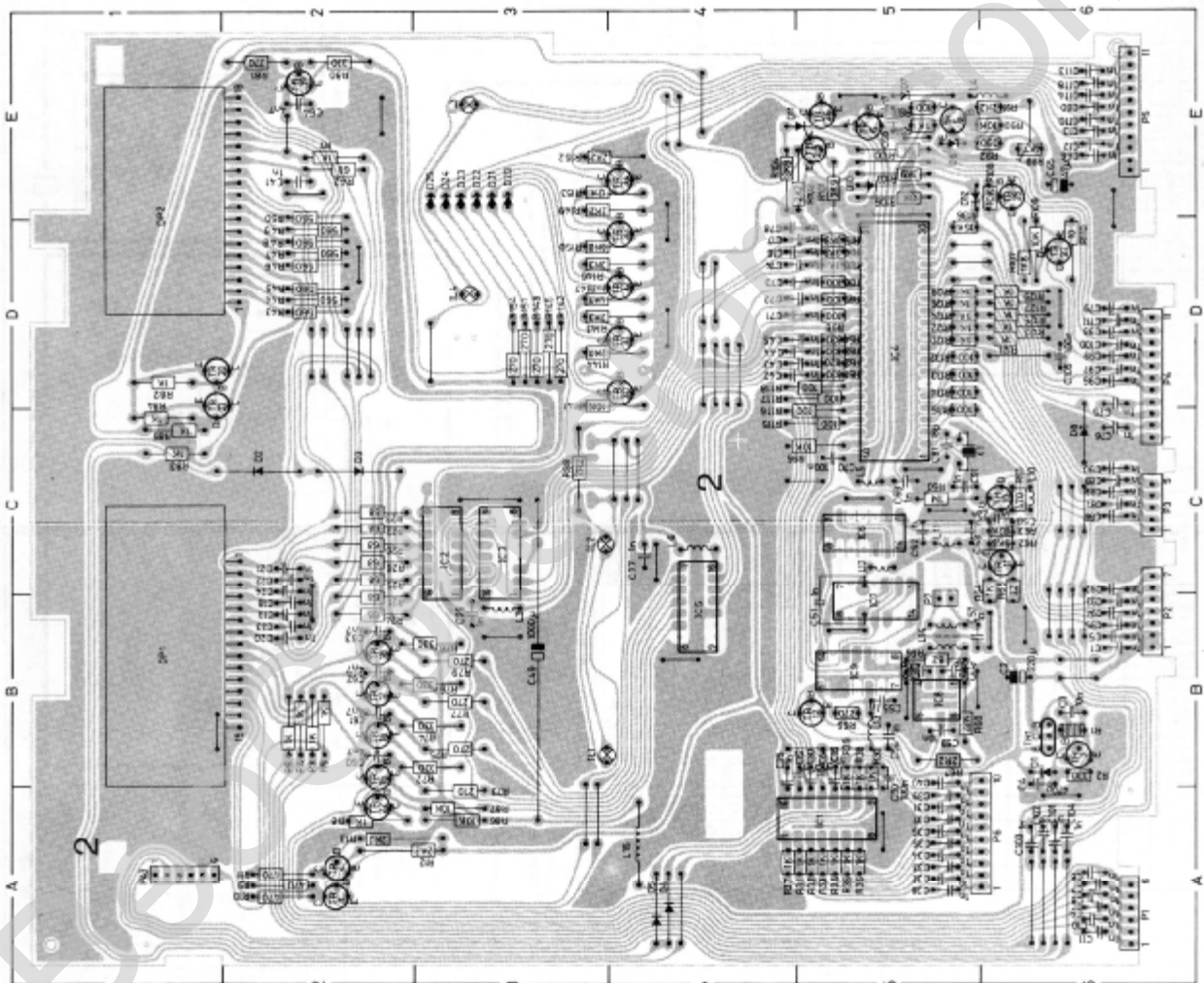
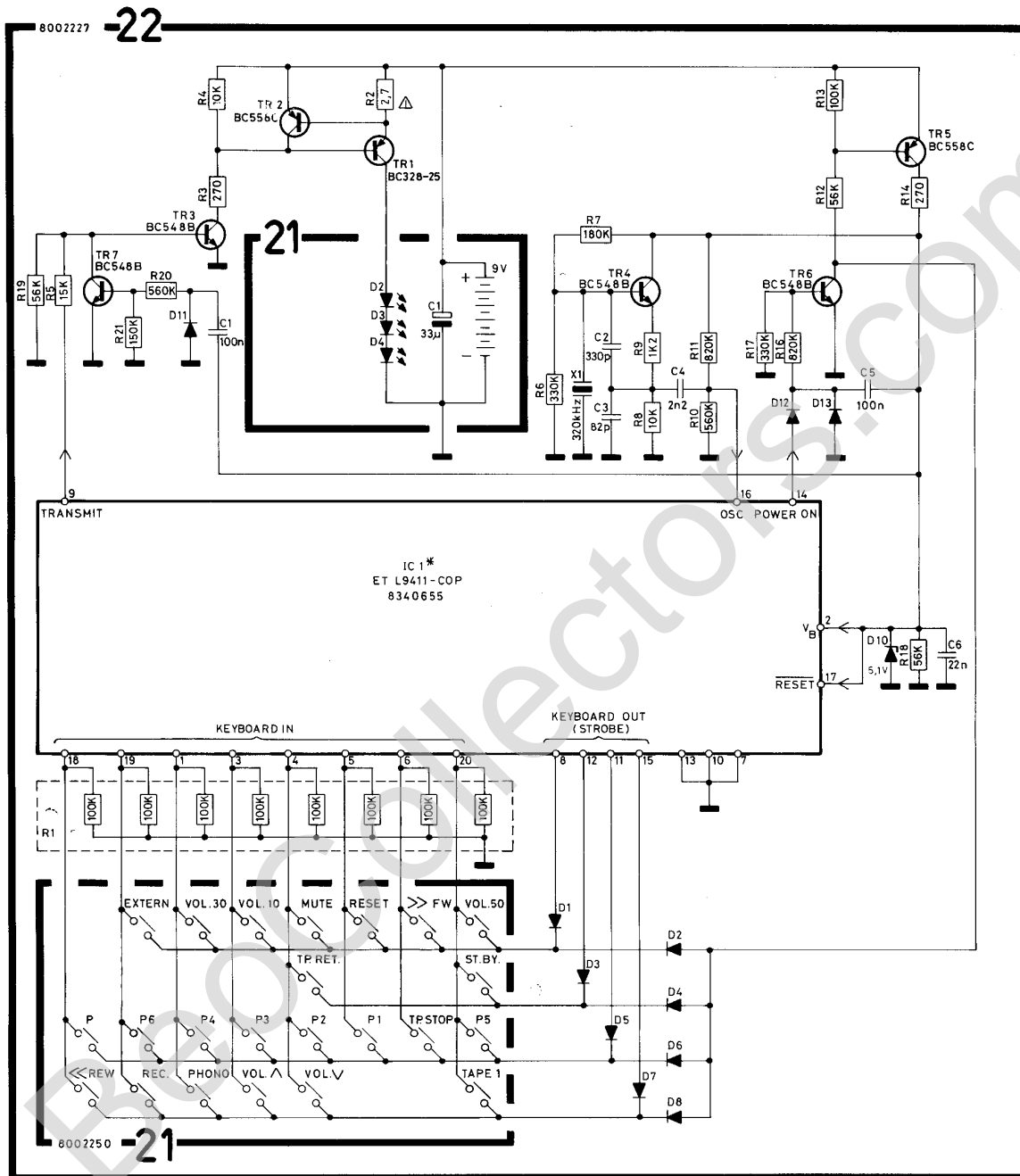

DIAGRAM 4 FOR BEOMASTER TERMINAL TYPE 2035
(Based on IC - 8340655)



To paste into service manual 3538523, 3538524, 3538525 or 3538526 for Beomaster 6000 types 225x after page 1-7

12-84

3538613

1-7b

Bang & Olufsen

SEMI-CONDUCTORS

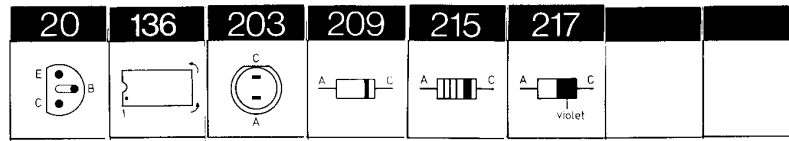

21D2-4	8330022	203	LD 271	22TR1	8320331	20	BC 328-25
			203 V-290-P				
22D1-8	8300058	217	SFD 184	22TR2	8320398	20	BC 558 C
			209 1N 4148	22TR3-4	8320108	20	BC 548 B
			215 1N 4148	22TR5	8320398	20	BC 558 C
22D10	8300169	209	BZX 79 5.1V	22TR6-7	8320108	20	BC 548 B
			209 ZPD 5.1V	22IC1* Δ	8340655	136	μ C
			209 BZX 83 5.1V				
22D11-13	8300058	217	SFD 184				
			209 1N 4148				
			215 1N 4148				

* Specially selected or adapted sample.
 Δ Static electricity may destroy the component.

LIST OF ELECTRICAL PARTS

Resistors not mentioned are standard 5%, 1/4 W carbon film.

PCB21, 8002250 Keyboard

C1 4200414 33 μ F 16V

PCB22, 8002227 Remote Transmitter

R1 5030017 8 x 100 k Ω 5% 1/8W
 R2 5020625 2.7 Ω 5% 0.3W

C1 4130224 100 nF 10% 63V
 C2 4010062 330 pF 10% 63V
 C3 4000200 82 pF 5% 63V
 C4 4010061 2.2 nF 10% 63V
 C5 4130224 100 nF 10% 63V
 C6 4130193 22 nF 20% 63V

X1 8030039 320 kHz \pm 1 kHz

LIST OF MECHANICAL PARTS

1804 3454303 Bund
 1806 2011032 Skrue 2,5 x 6 mm

Styklisten for de øvrige mekaniske dele findes på side 4-8

1804 3454303 Bottom
 1806 2011032 Screw 2.5 x 6 mm

The parts list for the other mechanical parts see page 4-8

1804 3454303 Boden
 1806 2011032 Schraube 2,5 x 6 mm

Stückliste für übrige mechanischen Teile sehen Sie Seite 4-8

1804 3454303 Fond
 1806 2011032 Vis 2,5 x 6 mm

Liste des pièces détachées des autres pièces mécaniques voir page 4-8

LIST OF TRANSISTORS

43							

2TR1	8320368	31	BD 533	6TR1	8320104	20	BC 558B
2TR2	8320329	20	BC 338-25	6TR2-	8320108	20	BC 548B
2TR3	8320152	20	BC 557B	6TR4			
2TR4				6TR5	8320316	20	BC 327-25
2TR5	8320097	20	BC 547B	6TR6	8320429	32	BD 435
2TR6	8320152	20	BC 557B	6TR7	8320108	20	BC 548B
2TR10	8320119	21	TIS 88A	6TR8			
2TR11	8320097	20	BC 547B	6TR9	8320295	20	BC 337-25
2TR12	8320152	20	BC 557B	7TR1	8320097	20	BC 547B
2TR15-	8320331	20	BC 328-25	7TR100/200	8320344	20	BC 550B
2TR19				8TR1	8320285	20	BC 548C
2TR20-	8320152	20	BC 557B	8TR2	8320281	42	BF 199
2TR22				8TR3			
2TR25	8320152	20	BC 557B	8TR4	8320108	20	BC 548B
2TR26	8320097	20	BC 547B	8TR5			
2TR27	8320152	20	BC 557B	8TR6	8320104	20	BC 558B
2TR28	8320097	20	BC 547B	8TR7	8320108	20	BC 548B
2TR30-	8320097	20	BC 547B	8TR8			
2TR34				8TR10	8320108	20	BC 548B
3TR1	8320097	20	BC 547B	8TR11			
3TR101/201	8320344	20	BC 550B	8TR12	8320104	20	BC 558B
3TR102/202	8320069	20	BC 559B	8TR13	8320152	20	BC 557B
3TR103/203				8TR14	8320104	20	BC 558B
3TR104/204	8320095	20	BC 549B	9TR1	8320242	20	BC 556B
4TR1-	8320152	20	BC 557B	9TR2	8320097	20	BC 547B
4TR7				9TR101/201	8320108	20	BC 548B

LIST OF P

9TR102/202	8320532	20	BC 550BS
9TR103/203			
9TR104/204	8320237	20	BC 546B
9TR105/205	8320108	20	BC 548B
9TR106/206	8320104	20	BC 558B
9TR107/207	8320454	17	BF 423
9TR108/208	8320108	20	BC 548B
9TR109/209	8320104	20	BC 558B
9TR110/210	8320460	43	BF 857
9TR111/211			

9TR112/212	8320370	26	BF 422
12TR1	8320331	20	BC 328-25
14TR1	8320152	20	BC 557B
14TR2	8320097	20	BC 547B
16TR1	8320097	20	BC 547B
16TR2	8320460	33	BD 536
16TR3	8320237	20	BC 546B
16TR4	8320097	20	BC 547B

LIST OF IC's

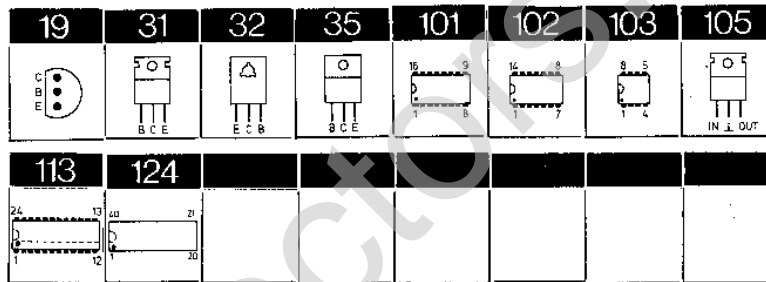

2IC1	8340192	101	SN 7445
2IC2	8340291	101	ULN 2003A
2IC3	8340290	101	SN 74LS248N
2IC4	8340285	124	μ C MK 3870/ 20
2IC5	8340192	101	SN 7445
2IC6	8340219	102	SN 74LS393
2IC7	8340289	102	SN 74LS93
2IC8	8340220	103	U264B
2IC9	8340289	102	SN 74LS93
3IC1	8340188	101	TDA 1029
3IC2	8340195	103	LF 353N 103 TL 072CP 103 μ AF 772TC
6IC1	8340054	19	MPSA 13
6IC2			

6IC3	8340212	105	MC 78M5CT 105 μ A 78M5 μ C
6IC5	8340232	102	LM 378N
6IC6	8340192	101	SN 7445
7IC100/200	8340054	19	MPSA 13
8IC1	8340198	101	TDA 1062
8IC2	8340233	101	CA 3189E
8IC3	8340284	101	TCA 4500A
9IC101/201	8340054	19	MPSA 13
9IC102/202	8340132	32	BDV 65A
9IC103/203			
9IC104/204	8340133	32	BDV 64A
9IC105/205			
12IC1	8340191	113	SN 76831 N- 24

14IC1	8340025	19	SPS 5431
		19	MPSA 65
14IC2	8340193	103	TDA 4050
16IC1	8340118	31	BDX 34A
		35	TEO 1089

16IC2	8340064	105	LM 340T-15
		105	μ A 7815 μ C
		105	MC 7815 CT

LIST OF DIODES AND DISPLAYS

203	206	209	215	217	219	222	226
230							

2D1	8300309	209	ZPD 4.7 2%
		209	BZX 83 C4V7
			2%
		209	BZX 79 C4V7
			2%
2D2-	8300058	217	SFD 184
2D5		215	1N 4148
		209	1N 4148
2D6	8300222	209	ZPD 2.7V 5%
		209	BZX 83C2V7
2D7	8300201	209	ZPD 6.2V 5%
2D8		209	BZX 79C6V2
		209	BZX 83C6V2
2D10-	8300058	217	SFD 184
2D12		215	1N 4148
		209	1N 4148
2D20-	8300255	206	CQX 10 red
2D24			
2D25	8330048	230	CQV 39-4 green
2DP1	8330036		FCS 8498
2DP2	8330029		FNA 8399
3D1	8300058	217	SFD 184
		215	1N 4148
		209	1N 4148
4D1-	8300058	217	SFD 184
4D8		215	1N 4148
		209	1N 4148

6D1	8300036	209	ZPD 4.7V 5%
		209	BZX 79 C4V7
		209	BZX 83 C4V7
6D2	8300023	209	1N 4002RL
6D3	8300169	209	ZPD 5.1V 5%
		209	BZX 79 C5V1
		209	BZX 83 C5V1
6D4	8300058	217	SFD 184
6D5		215	1N 4148
		209	1N 4148
6D8	8300058	217	SFD 184
		215	1N 4148
		209	1N 4148
7D1	8300058	217	SFD 184
		215	1N 4148
		209	1N 4148
8D1-	8300308	222	BB 204 blue
8D4			
8D5	8300306	226	BA 479
8D6	8340105	209	ZTK 27
9D101/201-	8300058	217	SFD 184
9D105/205		215	1N 4148
		209	1N 4148
9D106/206	8300029	209	ZPD 12V 5%
		209	BZX 79 12V
		209	BZX 83 12V

203	206	209	215	217	219	222	226
230							

9D107/207-	8300058	217	SFD 184	16D3	8300222	209	ZPD 2.7V 5%
9D111/211		215	1N 4148			209	BZX 83 C2V7
		209	1N 4148				
11D1	8300023	209	1N 4002 RL	16D4	8300303		B80C1500/ 1000
12D1	8300056	209	ZTE 1.5V 10%	16D5	8300058	217	SFD 184
12D2-	8330022	203	LD 271			215	1N 4148
12D4			V-290-P			209	1N 4148
14D1	8330004	219	SFH 205	16D7	8300323		125V 8/4A
14D2	8300058	217	SFD 184	16D8	8300313	209	ZPD 15V 2%
14D3		215	1N 4148			209	BZX 79 15V
		209	1N 4148				2%
						209	BZX 83 15V
							2%
16D1	8300297		B80C3700/ 2200				
16D2	8300135	209	ZPD 3.3V				
		209	BZX 79 C3V3				
		209	BZX 83 C3V3				

BeoCollection

LIST OF ELECTRICAL PARTS PC2, 8002522 Microcomputer

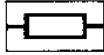

R1	5230008	50 ohms ±30% PTC	R80	5010044	330 ohms ±5% 1/8W
R2	5010044	330 ohms ±5% 1/8W	R81	5010044	270 ohms ±5% 1/8W
R3	5010040	1 kohms ±5% 1/8W	R82	5010040	1 kohms ±5% 1/8W
R4	5010040	1 kohms ±5% 1/8W	R83	5010040	1 kohms ±5% 1/8W
R5	5010040	1 kohms ±5% 1/8W	R84	5010040	1 kohms ±5% 1/8W
R6	5010040	1 kohms ±5% 1/8W	R85	5010040	1 kohms ±5% 1/8W
R7	5010040	1 kohms ±5% 1/8W	R86	5010059	10 kohms ±5% 1/8W
R8	5010040	1 kohms ±5% 1/8W	R87	5010059	10 kohms ±5% 1/8W
R9	5010058	470 ohms ±5% 1/8W	R88	5020469	2.2 ohms ±10% 1/2W
R10	5010058	470 ohms ±5% 1/8W	R89	5370058	4.7 kohms ±20% 0.1W
R11	5010058	470 ohms ±5% 1/8W	R90	5010059	10 kohms ±5% 1/8W
R12	5010064	2.2 kohms ±5% 1/8W	R91	5010064	2.2 kohms ±5% 1/8W
R13	5010064	2.2 kohms ±5% 1/8W	R92	5010070	390 ohms ±5% 1/8W
R14	5010069	3.9 kohms ±5% 1/8W	R93	5010065	100 ohms ±5% 1/8W
R15	5010069	3.9 kohms ±5% 1/8W	R94	5010040	1 kohms ±5% 1/8W
R20	5001010	68 ohms ±10% 1/2W	R95	5010059	10 kohms ±5% 1/8W
R21	5001010	68 ohms ±10% 1/2W	R96	5010065	100 ohms ±5% 1/8W
R22	5001010	68 ohms ±10% 1/2W	R97	5010065	100 ohms ±5% 1/8W
R23	5001010	68 ohms ±10% 1/2W	R98	5010065	100 ohms ±5% 1/8W
R24	5001010	68 ohms ±10% 1/2W	R99	5010040	1 kohms ±5% 1/8W
R25	5001010	68 ohms ±10% 1/2W	R100	5010040	1 kohms ±5% 1/8W
R26	5001010	68 ohms ±10% 1/2W	R101	5010069	3.9 kohms ±5% 1/8W
R30	5010040	1 kohms ±5% 1/8W	R102	5010064	2.2 kohms ±5% 1/8W
R31	5010040	1 kohms ±5% 1/8W	R103	5010069	3.9 kohms ±5% 1/8W
R32	5010040	1 kohms ±5% 1/8W	R104	5010069	3.9 kohms ±5% 1/8W
R33	5010040	1 kohms ±5% 1/8W	R106	5010059	10 kohms ±5% 1/8W
R34	5010040	1 kohms ±5% 1/8W	R107	5010066	1.8 kohms ±5% 1/8W
R35	5010040	1 kohms ±5% 1/8W	R108	5010059	10 kohms ±5% 1/8W
R36	5010040	1 kohms ±5% 1/8W	R109	5010059	10 kohms ±5% 1/8W
R37	5010040	1 kohms ±5% 1/8W	R110	5020489	10 ohms ±10% 1/4W
R38	5010040	1 kohms ±5% 1/8W	R115	5010065	100 ohms ±5% 1/8W
R39	5010040	1 kohms ±5% 1/8W	R116	5010065	100 ohms ±5% 1/8W
R42	5010039	68 ohms ±5% 1/8W	R117	5010065	100 ohms ±5% 1/8W
R43	5010067	560 ohms ±5% 1/8W	R118	5010065	100 ohms ±5% 1/8W
R44	5010067	560 ohms ±5% 1/8W	R120	5010040	1 kohms ±5% 1/8W
R45	5010067	560 ohms ±5% 1/8W	R121	5010040	1 kohms ±5% 1/8W
R46	5010067	560 ohms ±5% 1/8W	R122	5010040	1 kohms ±5% 1/8W
R47	5010067	560 ohms ±5% 1/8W	R123	5010040	1 kohms ±5% 1/8W
R48	5010067	560 ohms ±5% 1/8W	R124	5010040	1 kohms ±5% 1/8W
R49	5010067	560 ohms ±5% 1/8W	R125	5010040	1 kohms ±5% 1/8W
R50	5010067	560 ohms ±5% 1/8W	R126	5010040	1 kohms ±5% 1/8W
R51	5010068	820 ohms ±5% 1/8W	R127	5010040	1 kohms ±5% 1/8W
R52	5010068	820 ohms ±5% 1/8W	R128	5010040	1 kohms ±5% 1/8W
R53	5010068	820 ohms ±5% 1/8W	R129	5010040	1 kohms ±5% 1/8W
R54	5010068	820 ohms ±5% 1/8W	R132	5010065	100 ohms ±5% 1/8W
R60	5010054	1 Mohms ±5% 1/8W	R133	5010065	100 ohms ±5% 1/8W
R61	5010058	470 ohms ±5% 1/8W	R134	5010065	100 ohms ±5% 1/8W
R62	5010041	5.6 kohms ±5% 1/8W	R135	5010065	100 ohms ±5% 1/8W
R63	5010091	82 kohms ±5% 1/8W	R136	5010053	15 kohms ±5% 1/8W
R64	5010040	1 kohms ±5% 1/8W	R141	5010059	10 kohms ±5% 1/8W
R65	5010048	22 ohms ±5% 1/8W	R142	5010000	270 ohms ±5% 1/8W
R66	5010056	82 ohms ±5% 1/8W	R143	5010076	3.3 kohms ±5% 1/8W
R67	5020488	2.2 ohms ±10% 1/4W	R144	5010298	2.7 kohms ±5% 1/8W
R68	5010079	22 kohms ±5% 1/8W	R145	5010000	270 ohms ±5% 1/8W
R69	5010000	270 ohms ±5% 1/8W	R146	5010076	3.3 kohms ±5% 1/8W
R72	5010044	330 ohms ±5% 1/8W	R147	5010048	4.7 kohms ±5% 1/8W
R73	5010000	270 ohms ±5% 1/8W	R148	5010000	270 ohms ±5% 1/8W
R74	5010044	330 ohms ±5% 1/8W	R149	5010064	2.2 kohms ±5% 1/8W
R75	5010000	270 ohms ±5% 1/8W	R150	5010154	8.2 kohms ±5% 1/8W
R76	5010044	330 ohms ±5% 1/8W	R151	5010000	270 ohms ±5% 1/8W
R77	5010000	270 ohms ±5% 1/8W	R152	5010064	2.2 kohms ±5% 1/8W
R78	5010044	330 ohms ±5% 1/8W	R153	5010046	12 kohms ±5% 1/8W
R79	5010000	270 ohms ±5% 1/8W	R154	5010000	270 ohms ±5% 1/8W

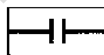

C1	4010098	1 nF ±10% 100V	C13	4010027	1 nF ±10% 100V
C2	4200118	220 nF 10V	C16	4010027	1 nF ±10% 100V
C3	4010041	10 nF -20+80% 40V	C17	4010027	1 nF ±10% 100V
C4	4010024	470 pF ±10% 100V	C18	4010027	1 nF ±10% 100V
C5	4010098	1 nF ±10% 100V	C19	4010027	1 nF ±10% 100V
C6	4010027	1 nF ±10% 100V	C20	4010027	1 nF ±10% 100V
C7	4010027	1 nF ±10% 100V	C21	4010027	1 nF ±10% 100V
C8	4010027	1 nF ±10% 100V	C22	4010027	1 nF ±10% 100V
C9	4010027	1 nF ±10% 100V	C23	4010027	1 nF ±10% 100V
C10	4010027	1 nF ±10% 100V	C24	4010027	1 nF ±10% 100V
C11	4010027	1 nF ±10% 100V	C25	4010027	1 nF ±10% 100V
C12	4010027	1 nF ±10% 100V	C26	4010027	1 nF ±10% 100V

C30	4030027	100 nF ±20% 25V	C73	4010027	1 nF ±10% 100V
C31	4010027	1 nF ±10% 100V	C74	4010027	1 nF ±10% 100V
C32	4010027	1 nF ±10% 100V	C75	4010098	1 nF ±10% 100V
C33	4010027	1 nF ±10% 100V	C76	4010098	1 nF ±10% 100V
C34	4010027	1 nF ±10% 100V	C77	4010027	1 nF ±10% 100V
C35	4010027	1 nF ±10% 100V	C78	4010027	1 nF ±10% 100V
C36	4010027	1 nF ±10% 100V	C79	4010098	1 nF ±10% 100V
C37	4010027	1 nF ±10% 100V	C80	4010027	1 nF ±10% 100V
C38	4010027	1 nF ±10% 100V	C81	4000081	18 pF ±5% 63V
C39	4010027	1 nF ±10% 100V	C82	4010027	1 nF ±10% 100V
C40	4010027	1 nF ±10% 100V	C83	4010027	1 nF ±10% 100V
C41	4010027	1 nF ±10% 100V	C84	4010027	1 nF ±10% 100V
C42	4010027	1 nF ±10% 100V	C85	4010027	1 nF ±10% 100V
C43	4010027	1 nF ±10% 100V	C86	4010098	1 nF ±10% 100V
C44	4010027	1 nF ±10% 100V	C87	4010098	1 nF ±10% 100V
C45	4010027	1 nF ±10% 100V	C88	4010098	1 nF ±10% 100V
C49	4200111	1000 µF 10V	C89	4010098	1 nF ±10% 100V
C50	4010060	22 nF -20+80% 40V	C90	4010098	1 nF ±10% 100V
C51	4010027	1 nF ±10% 100V	C91	4010027	1 nF ±10% 100V
C52	4010027	1 nF ±10% 100V	C92	4010098	1 nF ±10% 100V
C53	4010027	1 nF ±10% 100V	C93	4010098	1 nF ±10% 100V
C54	4010027	1 nF ±10% 100V	C94	4010098	1 nF ±10% 100V
C55	4010027	1 nF ±10% 100V	C95	4010098	1 nF ±10% 100V
C56	4010024	470 pF ±10% 100V	C96	4010098	1 nF ±10% 100V
C57	4010027	1 nF ±10% 100V	C97	4010098	1 nF ±10% 100V
C58	4010024	470 pF ±10% 100V	C98	4010098	1 nF ±10% 100V
C59	4010041	10 nF -20+80% 40V	C99	4010098	1 nF ±10% 100V
C60	4010063	4.7 nF ±10% 63V	C100	4010098	1 nF ±10% 100V
C61	4010063	4.7 nF ±10% 63V	C101	4010027	1 nF ±10% 100V
C62	4010063	4.7 nF ±10% 63V	C102	4010027	1 nF ±10% 100V
C63	4010063	4.7 nF ±10% 63V	C103	4010027	1 nF ±10% 100V
C64	4010063	4.7 nF ±10% 63V	C104	4010027	1 nF ±10% 100V
C65	4200092	47 µF 10V	C105	4030027	100 nF ±20% 25V
C66	4010027	1 nF ±10% 100V	C110	4010027	1 nF ±10% 100V
C68	4010063	4.7 nF ±10% 63V	C111	4010098	1 nF ±10% 100V
C69	4010027	1 nF ±10% 100V	C113	4010027	1 nF ±10% 100V
C70	4030027	100 nF ±20% 25V	C114	4010027	1 nF ±10% 100V
C71	4010027	1 nF ±10% 100V	C118	4010027	1 nF ±10% 100V
C72	4010027	1 nF ±10% 100V			

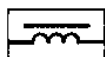

L3	8020342	10 mH	L11	8020342	10 mH
L4	8020342	10 mH	L12	8020342	10 mH
L5	8020342	10 mH	L13	8020342	10 mH
L6	8020342	10 mH	L14	8020341	100 mH
L10	8020342	10 mH	L15	8020092	Coil



X1	8090010	3.975 MHz
----	---------	-----------



IL1	8230062	6V 1W	IL3	8230060	6V 80 mA
IL2	8230062	6V 1W	IL4	8230060	6V 80 mA

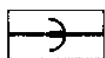

P1	7220167	Plug 6 pins	P5	7220177	Plug 11 pins
P2	7220247	Plug 7 pins	P6	7220169	Plug 10 pins
P3	7220246	Plug 5 pins	P7	7220176	Plug 2 pins
P4	7220177	Plug 11 pins	P43	7220167	Plug 6 pins

7200045 Socket for IC

PC3, 8002505 Tonecontrol and Switch

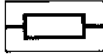

R1	5010040	1 kohms ±5% 1/8W	R214	5010040	1 kohms ±5% 1/8W
R2	5010059	10 kohms ±5% 1/8W	R215	5010053	15 kohms ±5% 1/8W
R3	5010049	100 kohms ±5% 1/8W	R216	5010044	330 ohms ±5% 1/8W
R4	5300113	100 kohms -	R218	5010392	3.9 Mohms ±5% 1/4W
R5	5310103	2 x 22 kohms - <i>træbe</i>	R219	5010077	470 kohms ±5% 1/8W
R6	5310103	2 x 22 kohms - <i>baa</i>	R220	5010059	10 kohms ±5% 1/8W
R7	5310104	2 x 22 kohms - <i>baa</i>	R221	5020080	5.6 kohms ±5% 1/8W
R8	5010045	47 kohms ±5% 1/8W	R222	5020106	1.5 kohms ±5% 1/8W
R9	5010045	47 kohms ±5% 1/8W	R223	5010048	4.7 kohms ±5% 1/8W
R10	5010045	47 kohms ±5% 1/8W	R224	5010298	2.7 kohms ±5% 1/8W
R201	5020263	100 kohms ±1% 1/8W	R225	5010040	1 kohms ±5% 1/8W
R202	5020263	100 kohms ±1% 1/8W	R226	5010048	4.7 kohms ±5% 1/8W
R203	5010059	10 kohms ±5% 1/8W	R227	5010066	1.8 kohms ±5% 1/8W
R204	5010065	100 ohms ±5% 1/8W	R228	5010041	5.6 kohms ±5% 1/8W
R205	5010059	10 kohms ±5% 1/8W	R230	5010063	150 kohms ±5% 1/8W
R206	5010075	33 kohms ±5% 1/8W	R231	5010076	3.3 kohms ±5% 1/8W
R207	5010120	220 kohms ±5% 1/8W	R233	5010066	1.8 kohms ±5% 1/8W
R208	5010075	33 kohms ±5% 1/8W	R234	5010041	5.6 kohms ±5% 1/8W
R209	5010120	220 kohms ±5% 1/8W	R235	5010052	6.8 kohms ±5% 1/8W
R210	5010049	100 kohms ±5% 1/8W	R236	5010120	220 kohms ±5% 1/8W
R211	5010049	100 kohms ±5% 1/8W	R237	5010049	100 kohms ±5% 1/8W
R212	5010049	100 kohms ±5% 1/8W	R238	5010040	1 kohms ±5% 1/8W
R213	5010049	100 kohms ±5% 1/8W			

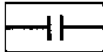

C1	4010027	1 nF ±10% 100V	C212	4010024	470 pF ±10% 100V
C2	4201074	47 µF 40V	C213	4201069	2.2 µF ±20% 35V
C3	4010060	22 nF -20+80% 40V	C214	4201035	2.2 µF -10+50% 63V
C4	4200099	100 µF 16V	C215	4010027	1 nF ±10% 100V
C5	4130150	100 nF ±20% 100V	C216	4010024	470 pF ±10% 100V
C6	4010060	22 nF -20+80% 40V	C217	4010063	4.7 nF ±10% 63V
C7	4010060	22 nF -20+80% 40V	C218	4010063	4.7 nF ±10% 63V
C201	4000016	10 pF ±2% 63V	C219	4200471	2.2 µF -10+50% 63V
C202	4200342	10 µF -10+50% 63V	C220	4130100	68 nF ±10% 250V
C203	4000057	47 pF ±5% 63V	C221	4010024	470 pF ±10% 100V
C204	4130104	220 nF ±20% 100V	C222	4010063	4.7 nF ±10% 63V
C205	4000057	47 pF ±5% 63V	C223	4010063	4.7 nF ±10% 63V
C206	4130104	220 nF ±20% 100V	C224	4200471	2.2 µF -10+50% 63V
C207	4000030	15 pF ±5% 63V	C225	4130100	68 nF ±10% 250V
C208	4130104	220 nF ±20% 100V	C226	4201035	2.2 µF -10+50% 63V
C209	4000030	15 pF ±5% 63V	C227	4010027	1 nF ±10% 100V
C210	4130104	220 nF ±20% 100V	C228	4003128	100 pF ±5% 63V
C211	4000023	150 pF ±5% 63V	C229	4003128	100 pF ±5% 63V

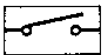

S1	7400232	FM-switch
S2	7400200	Loudn. - switch

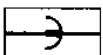

P8	7220167	Plug 6 pins	P12	7220144	Plug 9/8 pins
P9	7220166	Plug 3 pins	P13	7220181	Plug 7/6 pins
P10	7220168	Plug 8 pins	P14	7220201	Plug 4 pins
P11	7220168	Plug 8 pins			

PC4, 2542568 FM-Tuning



R1	5010059	10 kohms ±5% 1/8W	R13	5010120	220 kohms ±5% 1/8W
R2	5010054	1 Mohms ±5% 1/8W	R14	5320021	100 kohms Spec.
R3	5010120	220 kohms ±5% 1/8W	R15	5010053	15 kohms ±5% 1/8W
R4	5010053	15 kohms ±5% 1/8W	R16	5010120	220 kohms ±5% 1/8W
R5	5320021	100 kohms Spec.	R17	5320021	100 kohms Spec.
R6	5010120	220 kohms ±5% 1/8W	R18	5010053	15 kohms ±5% 1/8W
R7	5010053	15 kohms ±5% 1/8W	R19	5010120	220 kohms ±5% 1/8W
R8	5320021	100 kohms Spec.	R20	5320021	100 kohms Spec.
R9	5010053	15 kohms ±5% 1/8W	R21	5010053	15 kohms ±5% 1/8W
R10	5010120	220 kohms ±5% 1/8W	R22	5010120	220 kohms ±5% 1/8W
R11	5320021	100 kohms Spec.	R23	5320022	100 kohms Spec.
R12	5010053	15 kohms ±5% 1/8W			

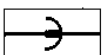

P15	7220266	Plug 5/4 pins
P16	7220268	Plug 8/7 pins

3-4

Bang & Olufsen

PC5, 8002507 Motor

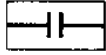

R5	5020135	12 ohms ±10% 1/4W
R6	5310102	2 x 47 kohms + 100 kohms

C5	4011005	2.2 nF -20+50% 400V
C6	4130155	1 µF ±10% 100V

PC6, 8002474 Motorcontrol



P17	7220182	Plug 10/9 pins
-----	---------	----------------

R1	5001016	150 ohms ±10% 1/2W	R29	5001032	1.5 kohms ±10% 1/2W
R2	5001000	8.2 ohms ±10% 1/2W	R30	5010075	33 kohms ±5% 1/8W
R3	5370049	1 Mohms ±20% 0.1W	R31	5010075	33 kohms ±5% 1/8W
R4	5001000	8.2 ohms ±10% 1/2W	R32	5370061	47 kohms ±20% 0.1W
R5	5001004	22 ohms ±10% 1/2W	R33	5020263	100 kohms ±1% 1/8W
R6	5001016	150 ohms ±10% 1/2W	R34	5010075	33 kohms ±5% 1/8W
R7	5010075	33 kohms ±5% 1/8W	R35	5010059	10 kohms ±5% 1/8W
R8	5010120	220 kohms ±5% 1/8W	R36	5010075	33 kohms ±5% 1/8W
R9	5010040	1 kohms ±5% 1/8W	R37	5010075	33 kohms ±5% 1/8W
R10	5010057	150 ohms ±5% 1/8W	R38	5020263	100 kohms ±1% 1/8W
R11	5370128	100 kohms ±20% 0.1W	R39	5010074	680 kohms ±5% 1/8W
R12	5010058	470 ohms ±5% 1/8W	R41	5020247	34 kohms ±1% 1/8W
R13	5010075	33 kohms ±5% 1/8W	R42	5020236	20 kohms ±1% 1/8W
R14	5010049	100 kohms ±5% 1/8W	R43	5020139	12.1 kohms ±1% 1/8W
R15	5010153	1.2 kohms ±5% 1/8W	R44	5020340	8.06 kohms ±1% 1/8W
R16	5010059	10 kohms ±5% 1/8W	R45	5020374	4.42 kohms ±0.5% 1/8W
R17	5010074	680 kohms ±5% 1/8W	R46	5010144	680 ohms ±5% 1/8W
R18	5020263	100 kohms ±1% 1/8W	R47	5020110	10 kohms ±1% 1/8W
R19	5020263	100 kohms ±1% 1/8W	R48	5010040	1 kohms ±5% 1/8W
R20	5010000	270 ohms ±5% 1/8W	R49	5010040	1 kohms ±5% 1/8W
R21	5010000	270 ohms ±5% 1/8W	R50	5010153	1.2 kohms ±5% 1/8W
R22	5010298	2.7 kohms ±5% 1/8W	R51	5370050	1 kohms ±20% 0.1W
R23	5010298	2.7 kohms ±5% 1/8W	R52	5001002	15 ohms ±10% 1/2W
R24	5370050	1 kohms ±20% 0.1W	R53	5010058	470 ohms ±5% 1/8W
R25	5370050	1 kohms ±20% 0.1W	R54	5010049	100 kohms ±5% 1/8W
R26	5010075	33 kohms ±5% 1/8W	R55	5020482	4.7 ohms ±10% 0.7W
R27	5010058	470 ohms ±5% 1/8W	R56	5020482	4.7 ohms ±10% 0.7W
R28	5001024	470 ohms ±10% 1/2W			

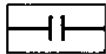

C4	4130215	220 nF ±20% 63V	C12	4010041	10 nF -20+80% 40V
C7	4200484	10 µF 63V	C13	4010041	10 nF -20+80% 40V
C8	4130106	330 nF ±20% 100V	C14	4130179	100 nF ±20% 63V
C9	4200472	10000 µF 25V	C15	4130213	10 nF ±10% 63V
C10	4010041	10 nF -20+80% 40V	C16	4130213	10 nF ±10% 63V
C11	4010041	10 nF -20+80% 40V			

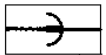

P2	6275460	Wire bundle with plug	P18	7220128	Socket/housing 6/5 pol.
	7500114	Contact pin	P19	7220269	Socket/housing 10/11 pol.
P5	6275460	Wire bundle with plug	P20	7220203	Socket/housing 10/9 pol.
	7500161	Contact pin			

3358083	Heat sink for IC3	2380011	Nut M3 DIN 934
2039020	Screw AM3 x 5 DIN 7985	2624032	Washer

PC7, 8002470 Rias Amp.



R1	5010040	1 kohms ±5% 1/8W	R205	5020183	464 ohms ±1% 1/8W
R2	5010059	10 kohms ±5% 1/8W	R206	5010047	120 kohms ±5% 1/8W
R200	5010092	220 ohms ±5% 1/8W	R207	5010362	180 ohms ±5% 1/8W
R201	5010045	47 kohms ±5% 1/8W	R208	5010048	4.7 kohms ±5% 1/8W
R202	5020275	267 kohms ±1% 1/8W	R209	5020019	36 kohms ±2% 1/8W
R203	5020183	464 ohms ±1% 1/8W	R210	5020456	200 kohms ±1% 1/8W
R204	5010066	1.8 kohms ±5% 1/8W			

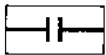

C2	4201074	47 µF 40V	C203	4000091	68 pF ±2% 63V
C3	4010060	22 nF -20+80% 40V	C204	4010102	2.7 nF ±10% 63V
C200	4200423	2.2 µF ±20% 50V	C205	4130109	10 nF ±10% 250V
C201	4000029	220 pF ±5% 63V	C206	4000057	47 pF ±5% 63V
C202	4130100	68 nF ±10% 250V			

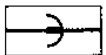

P23	7220160	Plug 5/4 pins
P24	7220267	Plug 6/5 pins

PC8, 8002472 FM
(Type 2251, 2252)



R1	5370225	47 kohms ±10% 0.1W	R47	5370058	4.7 kohms ±20% 0.1W
R2	5370225	47 kohms ±10% 0.1W	R48	5010411	47 ohms ±5% 1/8W
R3	5370225	47 kohms ±10% 0.1W	R49	5010049	100 kohms ±5% 1/8W
R4	5370225	47 kohms ±10% 0.1W	R50	5010045	47 kohms ±5% 1/8W
R5	5010079	22 kohms ±5% 1/8W	R51	5010848	3.3 Mohms ±5% 1/8W
R6	5010053	15 kohms ±5% 1/8W	R52	5010074	680 kohms ±5% 1/8W
R7	5010062	68 kohms ±5% 1/8W	R53	5010059	10 kohms ±5% 1/8W
R8	5010062	68 kohms ±5% 1/8W	R54	5010045	47 kohms ±5% 1/8W
R9	5010062	68 kohms ±5% 1/8W	R55	5010077	470 kohms ±5% 1/8W
R12	5010075	33 kohms ±5% 1/8W	R56	5010045	47 kohms ±5% 1/8W
R13	5010064	2.2 kohms ±5% 1/8W	R57	5010045	47 kohms ±5% 1/8W
R15	5010053	15 kohms ±5% 1/8W	R58	5010040	1 kohms ±5% 1/8W
R16	5010058	470 ohms ±5% 1/8W	R59	5010045	47 kohms ±5% 1/8W
R17	5010144	680 ohms ±5% 1/8W	R60	5010092	220 ohms ±5% 1/8W
R18	5010067	560 ohms ±5% 1/8W	R61	5010048	4.7 kohms ±5% 1/8W
R20	5010092	220 ohms ±5% 1/8W	R62	5010092	220 ohms ±5% 1/8W
R21	5020345	47 ohms ±10% 1/4W	R63	5010247	1.5 kohms ±5% 1/8W
R22	5010067	560 ohms ±5% 1/8W	R64	5370068	22 kohms ±20% 0.1W
R23	5010298	2.7 kohms ±5% 1/8W	R65	5010154	8.2 kohms ±5% 1/8W
R24	5010044	330 ohms ±5% 1/8W	R66	5370150	470 ohms ±20% 0.1W
R25	5010070	390 ohms ±5% 1/8W	R67	5010040	1 kohms ±5% 1/8W
R26	5010448	22 ohms ±5% 1/8W	R68	5010247	1.5 kohms ±5% 1/8W
R27	5011009	47 ohms ±5% 1/4W	R69	5010039	68 ohms ±5% 1/8W
R28	5011009	47 ohms ±5% 1/4W	R70	5010049	100 kohms ±5% 1/8W
R29	5010092	220 ohms ±5% 1/8W	R72	5011009	47 ohms ±5% 1/4W
R30	5010839	6.8 kohms ±5% 1/16W	R73	5011009	47 ohms ±5% 1/4W
R31	5010059	10 kohms ±5% 1/8W	R74	5010040	1 kohms ±5% 1/8W
R32	5010070	390 ohms ±5% 1/8W	R75	5010154	8.2 kohms ±5% 1/4W
R33	5010048	4.7 kohms ±5% 1/8W	R76	5370058	4.7 kohms ±20% 0.1W
R34	5010059	10 kohms ±5% 1/8W	R77	5010144	680 ohms ±5% 1/8W
R35	5010045	47 kohms ±5% 1/8W	R78	5001017	180 ohms ±10% 1/2W
R36	5010083	270 kohms ±5% 1/8W	R79	5370074	10 kohms ±20% 0.1W
R37	5010044	330 ohms ±5% 1/8W	R80	5010061	56 kohms ±5% 1/8W
R38	5010059	10 kohms ±5% 1/8W	R81	5010733	5.1 kohms ±5% 1/8W
R40	5010144	680 ohms ±5% 1/8W	R82	5010075	33 kohms ±5% 1/8W
R41	5010049	100 kohms ±5% 1/8W	R83	5010075	33 kohms ±5% 1/8W
R42	5370061	47 kohms ±20% 0.1W	R84	5010733	5.1 kohms ±5% 1/8W
R43	5370058	4.7 kohms ±20% 0.1W	R200	5010048	4.7 kohms ±5% 1/8W
R44	5010068	820 ohms ±5% 1/8W	R202	5370225	47 kohms ±10% 0.1W
R45	5010059	10 kohms ±5% 1/8W	R203	5010079	22 kohms ±5% 1/8W
R46	5010247	1.5 kohms ±5% 1/8W			

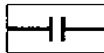

C1	4010060	22 nF -20+80% 40V	C55	4201065	10 µF 63V
C2	4200476	0.47 µF ±20% 50V	C56	4010041	10 nF -20+80% 40V
C3	4000104	4.7 pF ±0.25 pF 63V	C57	4010041	10 nF -20+80% 40V
C4	4000099	3.3 pF ±0.25 pF 63V	C58	4010041	10 nF -20+80% 40V
C5	4010027	1 nF ±10% 100V	C59	4010041	10 nF -20+80% 40V
C6	4010027	1 nF ±10% 100V	C60	4201061	4.7 µF 63V
C7	4010027	1 nF ±10% 100V	C65	4200380	1 µF -10+50% 63V
C8	4010027	1 nF ±10% 100V	C66	4201035	2.2 µF -10+50% 63V
C9	4000106	8.2 pF ±0.25 pF 250V	C69	4010060	22 nF -20+80% 40V
C11	4010087	470 pF ±10% 63V	C70	4010060	22 nF -20+80% 40V
C12	4011022	4.7 nF -20+80% 40V	C71	4200493	100 µF -10+100% 10V
C13	4000105	5.6 pF ±0.25 pF 63V	C72	4010060	22 nF -20+80% 40V
C14	4010087	470 pF ±10% 63V	C73	4201065	10 µF 63V
C15	4010024	470 pF ±10% 100V	C74	4010041	10 nF -20+80% 40V
C16	4011022	4.7 nF -20+80% 40V	C75	4010060	22 nF -20+80% 40V
C17	4000107	68 pF ±2% 63V	C80	4200099	100 µF 16V
C18	4011022	4.7 nF -20+80% 40V	C81	4201035	2.2 µF -10+50% 63V
C22	4000109	56 pF ±2% 63V	C82	4130050	6.8 nF ±10% 250V
C23	4010041	10 nF -20+80% 40V	C83	4130114	470 nF ±10% 100V
C24	4010024	470 pF ±10% 100V	C84	4130104	220 nF ±10% 100V
C25	4000085	100 pF ±2% 63V	C85	4101007	220 pF ±5% 63V
C26	4010041	10 nF -20+80% 40V	C87	4201061	4.7 µF 63V
C28	4000082	3.9 pF ±0.25 pF 63V	C88	4201065	10 µF 63V
C29	4000085	100 pF ±2% 63V	C89	4130104	220 nF ±20% 100V
C30	4000110	82 pF ±5% 63V	C91	4200296	2.2 µF 63V
C40	4010060	22 nF -20+80% 40V	C92	4130190	10 nF ±5% 250V
C41	4200342	10 µF -10+50% 63V	C93	4130190	10 nF ±5% 250V
C42	4010041	10 nF -20+80% 40V	C200	4130104	220 nF ±20% 100V
C46	4200476	0.47 µF ±20% 50V	C201	4100077	196 pF ±2.5% 63V
C47	4010041	10 nF -20+80% 40V	C202	4100080	866 pF ±2.5% 63V
C48	4000085	100 pF ±2% 63V	C203	4100081	2.15 nF ±2.5% 63V
C52	4010041	10 nF -20+80% 40V	C204	4100078	4.02 nF ±2.5% 63V
C53	4010041	10 nF -20+80% 40V	C205	4100079	590 pF ±2.5% 63V
C54	4010041	10 nF -20+80% 40V			

3-6

Bang & Olufsen

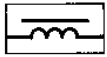

L1/R14	8020361	Coil	L7	8020323	IF 10.7 MHz
L2	8020322	Osc.	L8	8020368	IF 10.7 MHz
L3	8020321	RF	L9	8020369	IF 10.7 MHz
L4	8020320	RF coil	L200	8022079	78 mH
L5	8020319	Aerial coil	L201	8022079	78 mH
L6	6850127	1.2 µH			



BP1	8030014	10.7 MHz ±0.03 MHz
BP2	8030014	10.7 MHz ±0.03 MHz
BP3	8030014	10.7 MHz ±0.03 MHz



P25	7220279	Plug 2 pins	P28	7220116	Plug 8/7 pins
P26	7220279	Plug 2 pins	P29	7220116	Plug 8/7 pins
P27	7220160	Plug 5/4 pins	P30	7220160	Plug 5/4 pins

3304014	Cover for L1/L2 - L7
3304102	Cover for L8/L9
3302334	Cover for wire bundle
2395005	Contact spring

PC8, 8002508 FM (Type 2253)

C92	4130218	15 nF ±5% 250V
C93	4130218	15 nF ±5% 250V

Øvrige komponenter som i styklisten for PC8, 8002472

Other components as in parts list for PC8, 8002472

Übrige Komponenten wie in Stückliste für PC8, 8002472

Concernant la liste des autres composants voir PC8, 8002472

PC8, 8002539 FM (Type 2254)

R5	5010053	15 kohms ±5% 1/8W
----	---------	-------------------

C3	4000049	15 pF ±2% 63V
C4	4000075	12 pF ±2% 63V
C9	4000159	18 pF ±2% 100V
C13	4000049	15 pF ±2% 63V

Øvrige komponenter som i styklisten for PC8, 8002472

Other components as in parts list for PC8, 8002472

Übrige Komponenten wie in Stückliste für PC8, 8002472

Concernant la liste des autres composants voir PC8, 8002472

PC9, 8002487 Output Amp.

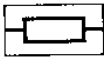

R1	5010064	2.2 kohms ±5% 1/8W	R228	5010053	15 kohms ±5% 1/8W
R2	5230008	50 ohms ±30%	R229	5010045	47 kohms ±5% 1/8W
R3	5010117	330 kohms ±5% 1/8W	R230	5010144	680 ohms ±5% 1/8W
R4	5010059	10 kohms ±5% 1/8W	R231	5010057	150 ohms ±5% 1/8W
R5	5010040	1 kohms ±5% 1/8W	R232	5010070	390 ohms ±5% 1/8W
R201	5010059	10 kohms ±5% 1/8W	R233	5010070	390 ohms ±5% 1/8W
R202	5010048	4.7 kohms ±5% 1/8W	R234	5370208	100 ohms ±20% 0.1W
R203	5010048	4.7 kohms ±5% 1/8W	R235	5010411	47 ohms ±5% 1/8W
R204	5010040	1 kohms ±5% 1/8W	R236	5010065	100 ohms ±5% 1/8W
R205	5010045	47 kohms ±5% 1/8W	R237	5001033	1.8 kohms ±10% 1/2W
R206	5010071	560 kohms ±5% 1/8W	R238	5001034	2.2 kohms ±10% 1/2W
R207	5010079	22 kohms ±5% 1/8W	R239	5001024	470 ohms ±10% 1/2W
R208	5010067	560 ohms ±5% 1/8W	R240	5001022	390 ohms ±10% 1/2W
R209	5010403	27 ohms ±5% 1/8W	R241	5001032	1.5 kohms ±10% 1/2W
R210	5370208	100 ohms ±20% 0.1W	R242	5001030	1.2 kohms ±10% 1/2W
R211	5010000	270 ohms ±5% 1/8W	R243	5100302	0.22 ohms ±10% 2W
R212	5010151	56 ohms ±5% 1/8W	R244	5100302	0.22 ohms ±10% 2W
R213	5010079	22 kohms ±5% 1/8W	R245	5001032	1.5 kohms ±10% 1/2W
R214	5010079	22 kohms ±5% 1/8W	R246	5001030	1.2 kohms ±10% 1/2W
R215	5010067	560 ohms ±5% 1/8W	R247	5001022	390 ohms ±10% 1/2W
R216	5010059	10 kohms ±5% 1/8W	R248	5001024	470 ohms ±10% 1/2W
R217	5001038	4.7 kohms ±10% 1/2W	R249	5001033	1.8 kohms ±10% 1/2W
R218	5010049	100 kohms ±5% 1/8W	R250	5001034	2.2 kohms ±10% 1/2W
R219	5010048	4.7 kohms ±5% 1/8W	R251	5011080	6.8 Mohms ±5% 1/4W
R220	5010048	4.7 kohms ±5% 1/8W	R252	5010059	10 kohms ±5% 1/8W
R221	5010039	68 ohms ±5% 1/8W	R253	5010075	33 kohms ±5% 1/8W
R222	5010057	150 ohms ±5% 1/8W	R254	5001022	390 ohms ±10% 1/2W
R223	5010039	68 ohms ±5% 1/8W	R255	5020482	4.7 ohms ±10% 1/2W
R224	5010045	47 kohms ±5% 1/8W	R256	5001024	470 ohms ±10% 1/2W
R225	5010053	15 kohms ±5% 1/8W	R257	5010117	330 kohms ±5% 1/8W
R226	5010058	470 ohms ±5% 1/8W	R259	5010067	560 ohms ±5% 1/8W
R227	5010058	470 ohms ±5% 1/8W			

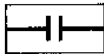

C1	4010063	4.7 nF ±10% 63V	C212	4010024	470 pF ±10% 100V
C200	4010063	4.7 nF ±10% 63V	C213	4200099	100 μF 16V
C201	4130155	1 μF ±10% 100V	C214	4010063	4.7 nF ±10% 63V
C202	4130104	220 nF ±20% 100V	C215	4130089	22 nF ±10% 250V
C203	4200368	100 μF 63V	C216	4010027	1 nF ±10% 100V
C204	4130193	22 nF ±20% 63V	C217	4130150	100 nF ±20% 100V
C205	4010024	470 pF ±10% 100V	C218	4200299	220 μF 40V
C206	4200364	47 μF -10+50% 10V	C219	4200328	220 μF -10+50% 40V
C207	4000112	56 pF ±5% 250V	C220	4010027	1 nF ±10% 100V
C208	4000021	6.8 pF ±0.25 pF 63V	C221	4130150	100 nF ±20% 100V
C209	4200378	100 μF -10+50% 4V	C222	4200411	47 μF -10+100% 6.3V
C210	4010063	4.7 nF ±10% 63V	C223	4130104	220 nF ±20% 100V
C211	4011025	3.3 nF ±10% 100V	C224	4130150	100 nF ±20% 100V

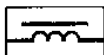

L201 6850114 Coil 0.5 μH

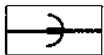

P31	7220266	Plug 5/4 pins	P34	7500080	Contact spear
P32	7220160	Plug 5/4 pins		7500158	Plug
P33	7220212	Plug 3 pins			

PC11, 8002462 Fuse and Relay (Type 2251, 2252)



F1	6600009	2A-T 250V S IEC 127
F2	6600039	160 mA-T 250V S IEC 127
	7500002	Fuse holder

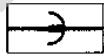

RL1 7600061 12V

P36	7220122	Plug 4/3 pins
	6275467	Wire bundle

50.000019 <100 ma

PC11, 8002506 Fuse and Relay (Type 2253, 2254)

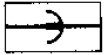

PC12, 8002496 Remote Transmitter

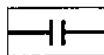

PC14, 8002476 Remote Receiver

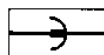
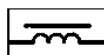
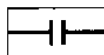
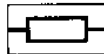

R1 5000194 3.3 Mohms $\pm 10\%$ 1/2W

F1 6600019 5A-T 250V
F2 6600040 300 mA-T 250V
7500002 Fuse holder

RL1 7600061 12V

P36 7220122 Plug 4/3 pins
6275467 Wire bundle

R1 5010064 2.2 kohms $\pm 5\%$ 1/8W
R2 5001164 3.3 ohms $\pm 10\%$ 1/2W
R3 5010040 1 kohms $\pm 5\%$ 1/8W

C1 4010024 470 pF $\pm 10\%$ 100V
C2 4010024 470 pF $\pm 10\%$ 100V
C4 4010021 220 pF $\pm 10\%$ 100V
C5 4010021 220 pF $\pm 10\%$ 100V
C6 4010021 220 pF $\pm 10\%$ 100V
C7 4010021 220 pF $\pm 10\%$ 100V
C8 4010021 220 pF $\pm 10\%$ 100V

X1 8030013 455 kHz

R1 5010120 220 kohms $\pm 5\%$ 1/8W
R2 5010059 10 kohms $\pm 5\%$ 1/8W
R3 5010298 2.7 kohms $\pm 5\%$ 1/8W
R4 5010298 2.7 kohms $\pm 5\%$ 1/8W
R7 5010247 1.5 kohms $\pm 5\%$ 1/8W
R8 5010040 1 kohms $\pm 5\%$ 1/8W
R9 5010065 100 ohms $\pm 5\%$ 1/8W
R16 5010059 10 kohms $\pm 5\%$ 1/8W
R17 5010059 10 kohms $\pm 5\%$ 1/8W
R18 5010061 56 kohms $\pm 5\%$ 1/8W
R19 5010052 6.8 kohms $\pm 5\%$ 1/8W

C1 4200016 22 μ F -10+50% 25V
C2 4000023 150 pF $\pm 5\%$ 63V
C3 4130193 22 nF $\pm 20\%$ 63V
C4 4010041 10 nF -20+80% 40V
C5 4201035 2.2 μ F -10+50% 63V
C6 4201035 2.2 μ F -10+50% 63V
C7 4100058 3.3 nF $\pm 2.5\%$ 63V
C8 4010067 1.5 nF $\pm 10\%$ 63V
C9 4010067 1.5 nF $\pm 10\%$ 63V
C10 4010063 4.7 nF $\pm 10\%$ 63V
C11 4200342 10 μ F -10+50% 63V
C12 4200342 10 μ F -10+50% 63V
C13 4010027 1 nF $\pm 10\%$ 100V

L1 8022106 78 mH

P37 7220122 Plug 4/3 pins

3304006 Cover for L1
3304052 Cover

PC16, 8002485 Power Supply



R1	5001008	47 ohms $\pm 10\%$ 1/2W	R8	5001034	2.2 kohms $\pm 10\%$ 1/2W
R2	5010092	220 ohms $\pm 5\%$ 1/8W	R9	5010069	3.9 kohms $\pm 5\%$ 1/8W
R3	5010058	470 ohms $\pm 5\%$ 1/8W	R10	5020116	7.87 kohms $\pm 1\%$ 1/8W
R4	5370059	250 ohms $\pm 20\%$ 0.1W	R11	5020110	10 kohms $\pm 1\%$ 1/8W
R5	5010048	4.7 kohms $\pm 5\%$ 1/8W	R12	5001008	47 ohms $\pm 10\%$ 1/2W
R6	5010076	3.3 kohms $\pm 5\%$ 1/8W	R13	5001032	1.5 kohms $\pm 10\%$ 1/2W
R7	5020135	12 ohms $\pm 10\%$ 1/4W			

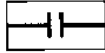

C1	4200470	3300 μ F 16V	C10	4200393	2200 μ F 40V
C2	4130104	220 nF $\pm 20\%$ 100V	C11	4130171	330 nF $\pm 20\%$ 63V
C3	4130104	220 nF $\pm 20\%$ 100V	C12	4130179	100 nF $\pm 20\%$ 63V
C4	4130104	220 nF $\pm 20\%$ 100V	C13	4010041	10 nF -20+80% 40V
C5	4010063	4.7 nF $\pm 10\%$ 63V	C17	4010063	4.7 nF $\pm 10\%$ 63V
C6	4010024	470 pF $\pm 10\%$ 100V	C18	4010024	470 pF $\pm 10\%$ 100V
C7	4010024	470 pF $\pm 10\%$ 100V	C19	4012002	10 nF -20+50% 400V
C8	4130103	100 nF $\pm 20\%$ 250V	C20	4200412	10000 μ F -10+50% 63V
C9	4130103	100 nF $\pm 20\%$ 250V	C21	4200412	10000 μ F -10+50% 63V

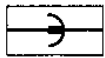

P34	6275468	Wire bundle with plug	P42	7220144	Plug 9/8 pins
P40	7220133	Plug 4 pins		7500013	Contact spear
P41	7220114	Plug 5/4 pins		7500158	Plug

PC17, 7219030 Socket Panel

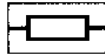

R1	5010040	1 kohms $\pm 5\%$ 1/8W	R4	5010040	1 kohms $\pm 5\%$ 1/8W
R2	5010040	1 kohms $\pm 5\%$ 1/8W	R5	5010040	1 kohms $\pm 5\%$ 1/8W
R3	5010040	1 kohms $\pm 5\%$ 1/8W	R6	5010040	1 kohms $\pm 5\%$ 1/8W

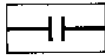

C1	4010060	22 nF -20+80% 40V
C2	4010060	22 nF -20+80% 40V
C3	4010060	22 nF -20+80% 40V



T1	8020341	Coil
----	---------	------

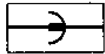

P10	7210117	Socket/housing 8 pol.	P30	7210161	Socket/housing 5/4 pol.
P11	7210117	Socket/housing 8 pol.		7500114	Contact pin
P12	7210155	Socket/housing 9/8 pol.	P25	6274032	Wire bundle with plug
P23	7210161	Socket/housing 5/4 pol.		6275459	Wire bundle for socket panel
P24	7210164	Socket/housing 6/5 pol.		7500161	Contact pin

BeoCollection

MEKANISK STYKLISTE LIST OF MECHANICAL PARTS

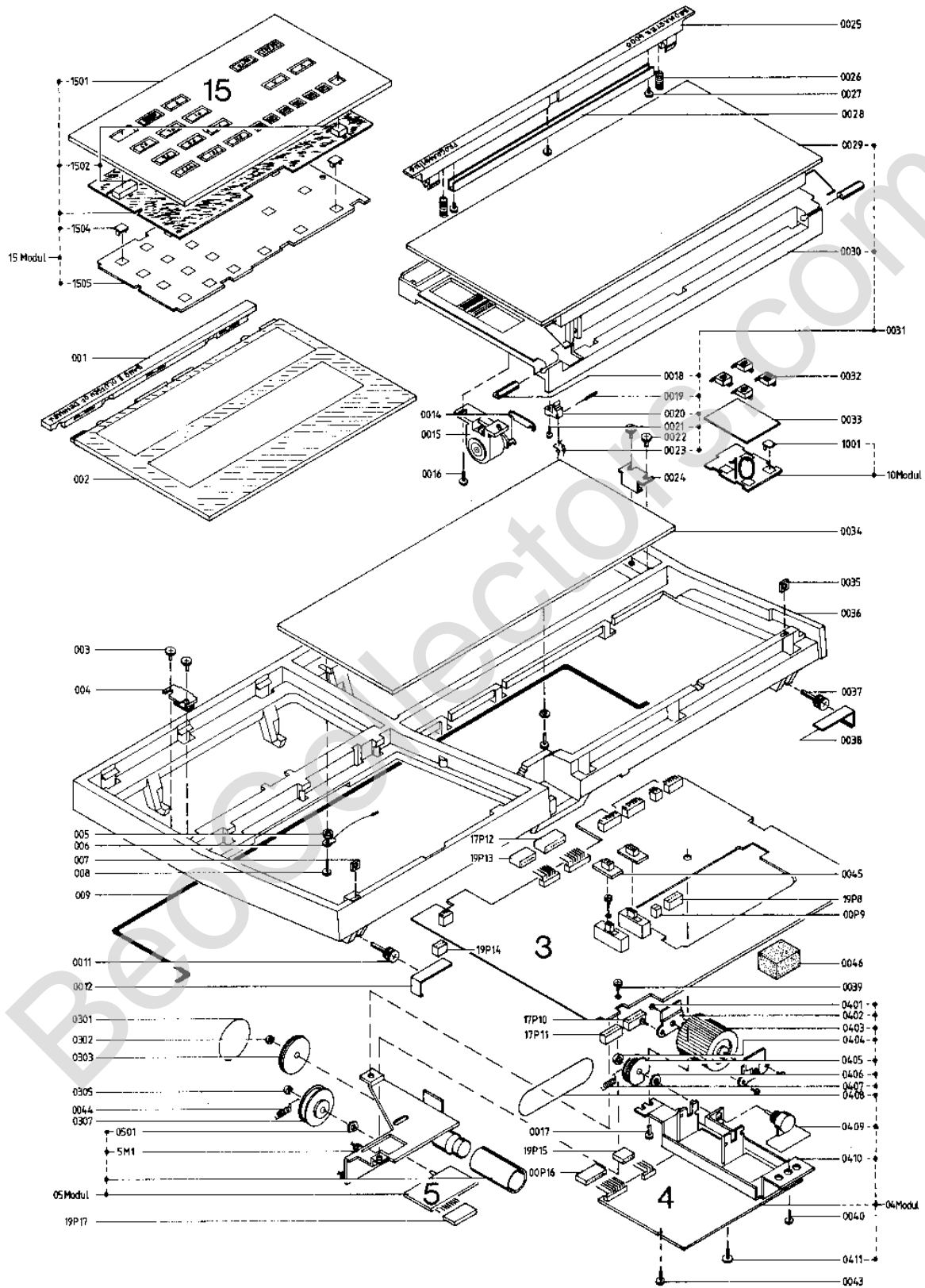

Upper Chassis

001	2560084	Profile	0026	2812084	Spring
002	3162148	Lid	0027	2013094	Screw 2.8 x 6.4 mm
003	2015090	Screw 3.5 x 6.4 mm	0028	2572024	Rail
004	2530361	Bracket	0029	3164418	Lid
005	2622015	Washer	0030	3168155	Panel
006	6273864	Chassis lead	0031	3164448	Cover, complete
007	2380122	Nut M4	0032	2775815	Knob
008	2039905	Screw AM 3 x 12 DIN 7985	0033	3170178	Foil
009	3150045	Clamp	0034	3162129	Lid
0011	2042031	Screw AM 4 x 30 DIN 933	0035	2380122	Nut M4
0012	3300088	Bracket	0036	3413891	Cabinet, teak
0014	2570063	Arm		3413893	Cabinet, rosewood
0015	3130061	Damping system		3413894	Cabinet, oak
0016	2013095	Screw 2.8 x 9.5 mm		3413895	Cabinet, white
0017	2015091	Screw 3.5 x 9.5 mm	0037	2042031	Screw AM 4 x 30 DIN 933
0018	2905080	Hinge	0038	3300088	Bracket
0019	2830071	Pin	0039	2039026	Screw AM 3 x 4 DIN 7985
0020	2391052	Lock	0040	2015091	Screw 3.5 x 9.5 mm
0021	2034046	Screw AM 2 x 8 DIN 7985	0043	2039903	Screw AM 3 x 5 DIN 7985
0022	2015090	Screw 3.5 x 6.4 mm	0044	2810131	Spring
0023	2819146	Spring	0045	2775709	Knob
0024	2530361	Bracket	0046	3947090	Foam
0025	2775832	Knob		3955035	Dial cord
<hr/>					
00P9	6275461	Wire bundle with plug			
00P16	6275461	Wire bundle with plug			
	7500114	Contact pin			
<hr/>					
03Modul	8002505	PC3, Tonecontrol and Switch	0303	2794087	Wheel
0301	2732054	Rubber belt	0305	2395006	Spire
0302	2395006	Spire	0307	2794087	Wheel
<hr/>					
04Modul	2542568	PC4, FM-Tuning	0407	2810131	Spring
0401	2013099	Screw 2.8 x 6.5 mm	0408	3955034	Dial cord
0402	2905090	Bearing	0409	6140812	PC-board, unassembled
0403	2794088	Wheel	0410	2542559	Bracket
0404	2395031	Spire	0411	2013112	Screw 2.9 x 4.5 mm DIN 7981
0405	2724033	Cord pulley			
0406	2380047	Nut			
<hr/>					
05Modul	8002507	PC5, Motor			
0501	2380047	Nut			
05M1	3151204	Motor with bracket			
<hr/>					
10Modul	8002488	PC10, Secondary Keyboard			
1001	7500148	Contact spring			
<hr/>					
10P43	6273963	Wire bundle with plug			
	7500161	Contact pin			
<hr/>					
15Modul	2775841	PC15, Primary Keyboard	1504	7500148	Contact spring
1501	3168147	Operating panel	1505	8002467	PC-board
1502	2775863	Set of knobs			
<hr/>					
17P10	7210117	Socket/housing 8 pol		7500114	Contact pin
17P11	7210117	Socket/housing 8 pol		6275459	Wire bundle with plug
17P12	7210155	Socket/housing 9/8 pol			
<hr/>					
19Modul	6275469	Main wire bundle	19P15	7210161	Socket/housing 5/4 pol
19P8	7210132	Socket/housing 6 pol	19P17	7210198	Socket/housing 10/9 pol
19P13	7210128	Socket/housing 7/6 pol		7500114	Contact pin
19P14	7210148	Socket/housing 4 pol			

4-3

Bang & Olufsen

Lower Chassis

0050	2015067	Screw 3.5 x 19 mm	0060	2530358	Bracket
0051	2938125	Rubber bushing	0061	7530008	Solder tag
0052	2015090	Screw 3.5 x 6.4 mm	0062	2015090	Screw 3.5 x 6.4 mm
0053	2389045	Nut	0063	3454281	Bottom plate
0054	3152304	Holder	0064	2015090	Screw 3.5 x 6.4 mm
0055	7210224	Jack-socket	0065	7530008	Solder tag
0056	2015090	Screw 3.5 x 6.4 mm	0066	3035026	Rubber foot
0057	2015090	Screw 3.5 x 6.4 mm	0067	3010010	Stop
0058	2015090	Screw 3.5 x 6.4 mm	0069	2819152	Spring
0059	2015202	Screw 3.5 x 13 m			
<hr/>					
00T1	8013258	Transformer, for type 2251-2252, 240V			
	8013271	Transformer, for type 2253, 120V			
	8013273	Transformer, for type 2254, 100V			
<hr/>					
00P26	6274038	Lead with plug			
	7500161	Contact pin			
00P40	6275464	Lead with plug			
	7500114	Contact pin			
<hr/>					
06Modul	8002474	PC6, Motor Control			
<hr/>					
07Modul	8002470	PC7, Rias-Amplifier			
<hr/>					
08Modul	8002472	PC8, FM for type 2251, 2252			
	8002508	PC8, FM for type 2253			
	8002539	PC8, FM for type 2254			
<hr/>					
11Modul	8002462	PC11, Fuse and Relay for type 2251, 2252			
	8002506	PC11, Fuse and Relay for type 2253, 2254			
<hr/>					
14Modul	8002476	PC14, Remote Receiver			
<hr/>					
17P23	7210161	Socket/housing 5/4 pol	6275459	Wire bundle for socket panel	
17P24	7210164	Socket/housing 6/5 pol	17P25	6274032	Wire bundle with plug
17P30	7210161	Socket/housing 5/4 pol		7500161	Contact pin
	7500114	Contact pin			
<hr/>					
19Modul	6275469	Main wire bundle	19P28	7210129	Socket/housing 8/7 pol
19P18	7210164	Socket/housing 6/5 pol	19P29	7210129	Socket/housing 8/7 pol
19P19	7210163	Socket/housing 11/10 pol	19P36	7210113	Socket/housing 4/3 pol
19P20	7210198	Socket/housing 10/9 pol	19P37	7210113	Socket/housing 4/3 pol
19P27	7210161	Socket/housing 5/4 pol		7500114	Contact pin

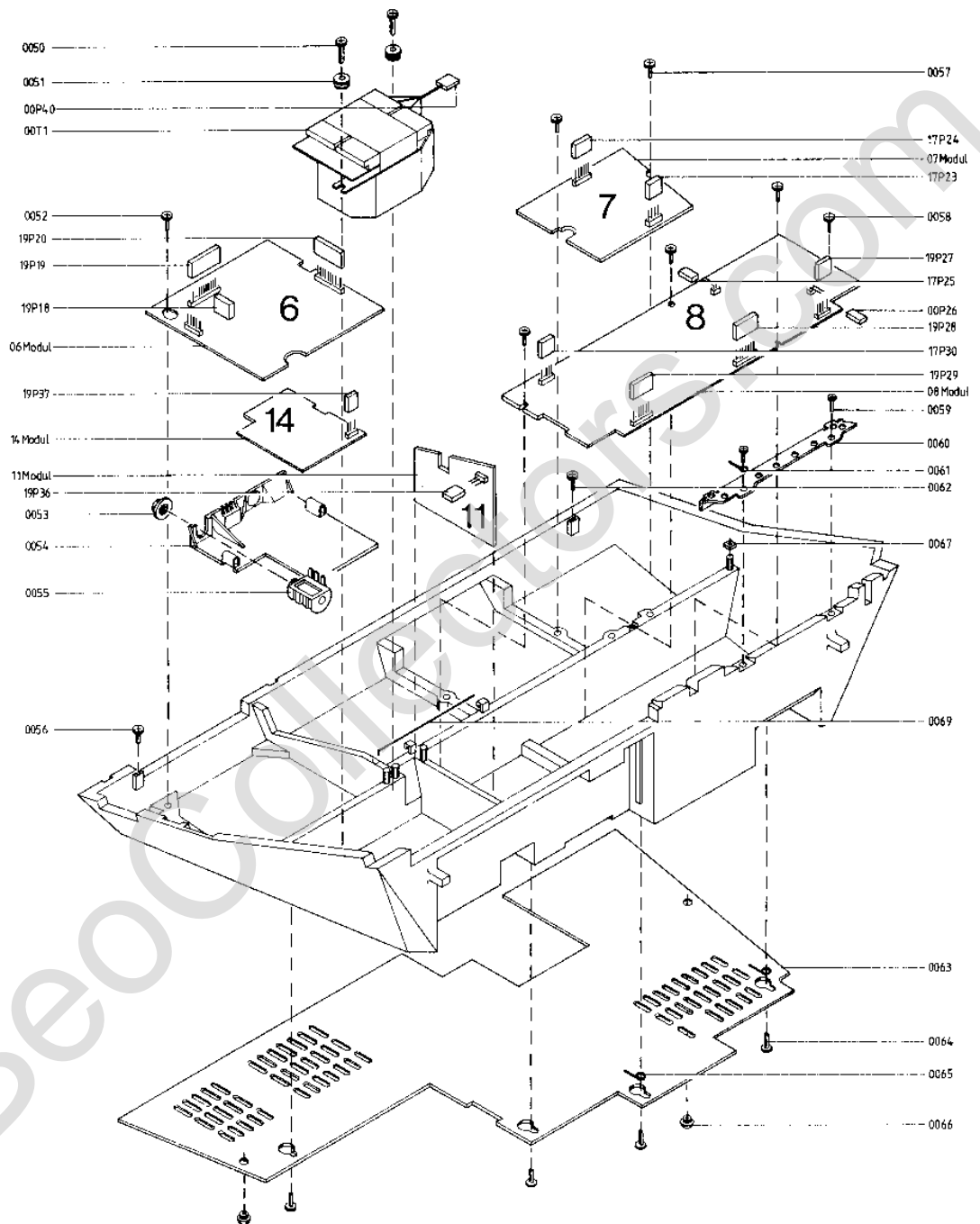

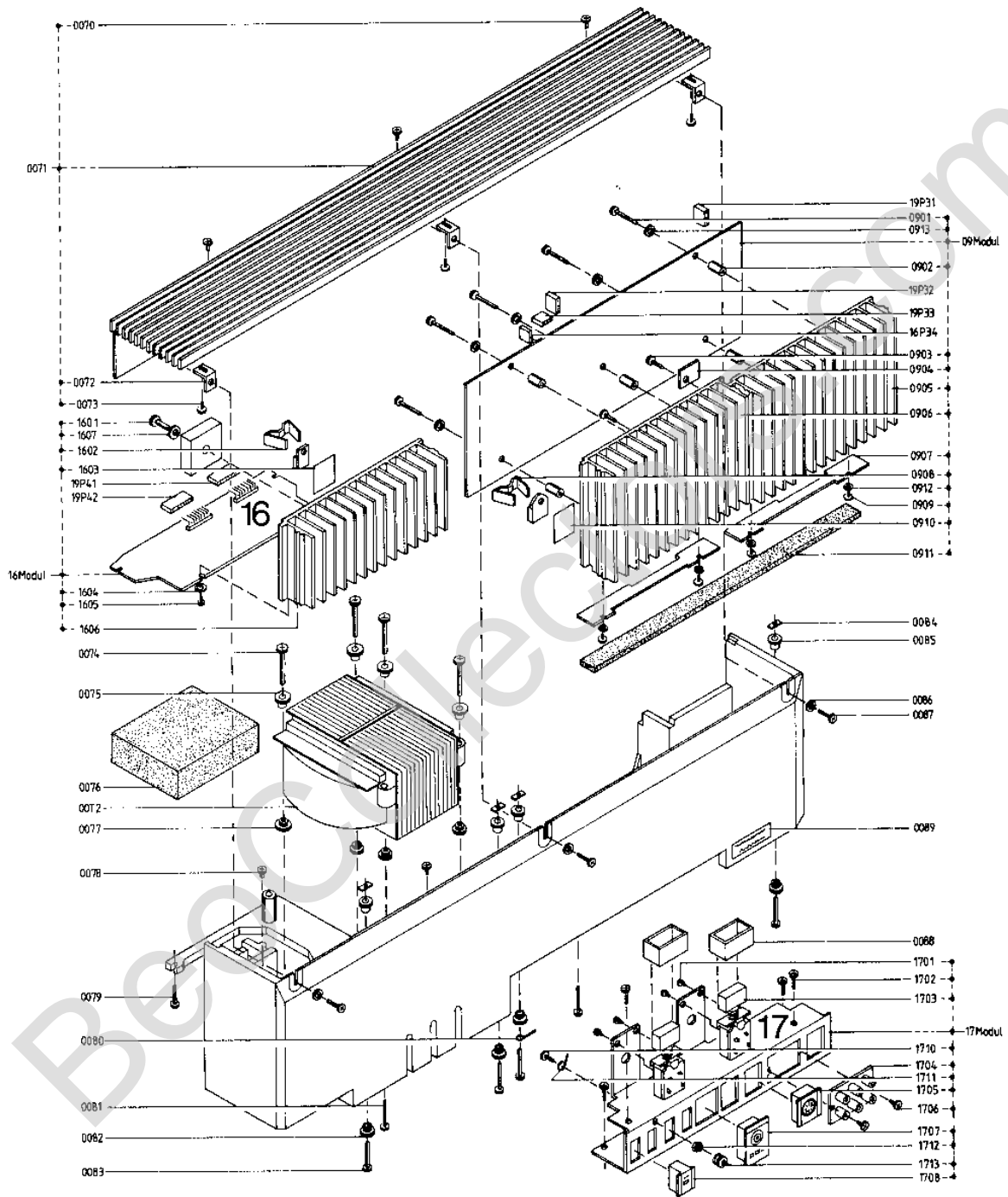

Rear Chassis

0070	2039026	Screw AM 3 x 4 DIN 7985	0081	2015071	Screw 3.5 x 25.4 mm
0071	3444127	Grill, assembled	0082	2938180	Bushing
0072	3151205	Bracket	0083	2013097	Screw 2.9 x 25 mm DIN 7981
0073	2039026	Screw AM 3 x 4 DIN 7985	0084	2395042	Spire
0074	2015072	Screw 3.5 x 31.8 mm	0085	2938180	Bushing
0075	2938154	Bushing	0086	2622048	Washer
0076	3917046	Foam	0087	2039028	Screw AM 3 x 8 DIN 7985
0077	2938154	Bushing	0088	3938013	Spacer
0078	2015090	Screw 3.5 x 6.4 mm	0089	3180889	Rear plate label, for type 2252
0079	2015066	Screw 3.5 x 16 mm		3180888	Rear plate label, for type 2253
0080	7530006	Solder tag		3180890	Rear plate label, for type 2254

00T2	8013257	Transformer, for type 2251-2252, 240V
	8013270	Transformer, for type 2253, 120V
	8013272	Transformer, for type 2254, 100V

09Modul	8002487	PC9, LF Output Amplifier	0908	2819157	Spring
0901	2039014	Screw AM 3 x 20 DIN 7985	0909	2013200	Screw 2.9 x 6.5 mm DIN 7981
0902	2938179	Spacer	0910	3170169	Mica sheet
0903	2039028	Screw AM 3 x 8 DIN 7985	0911	3947089	Tape
0904	6140808	PC-board, unassembled	0912	2622052	Fibre washer
0905	3358163	Heat sink, left	0913	2622052	Fibre washer
0906	3358164	Heat sink, right			
0907	6140808	PC-board, unassembled			

16Modul	8002485	PC16, Power Supply	1605	2013200	Screw 2.9 x 6.5 mm DIN 7981
1601	2043002	Screw AM 4 x 16 DIN 7985	1606	3358165	Heat sink
1602	2819157	Spring	1607	2624037	Washer
1603	3170169	Mica sheet			
1604	2622052	Fibre washer			

16P34	6275468	Wire bundle with plug
-------	---------	-----------------------

17Modul	7219030	PC17, Socket Panel	1707	7210279	Plug FM 240/60 ohms
	6140811	PC-board, unassembled	1708	7211047	2 pole DIN-plug
1701	2013094	Screw 2.8 x 6.4 mm	1710	2039028	Screw AM 3 x 8 DIN 7985
1702	2039028	Screw 2.9 x 8 mm DIN 7985	1711	7530008	Solder tag
1703	7450060	Mains switch for loud-speaker switch	1712	2380011	Nut M3
			1713	2382009	Milled nut
1704	7210298	Phono socket panel		6275459	Wire bundle for socket panel
1705	7210269	7 pole DIN-plug		7500161	Contact pin
1706	2039026	Screw AM 3 x 4 DIN 7985			

Microcomputer PC

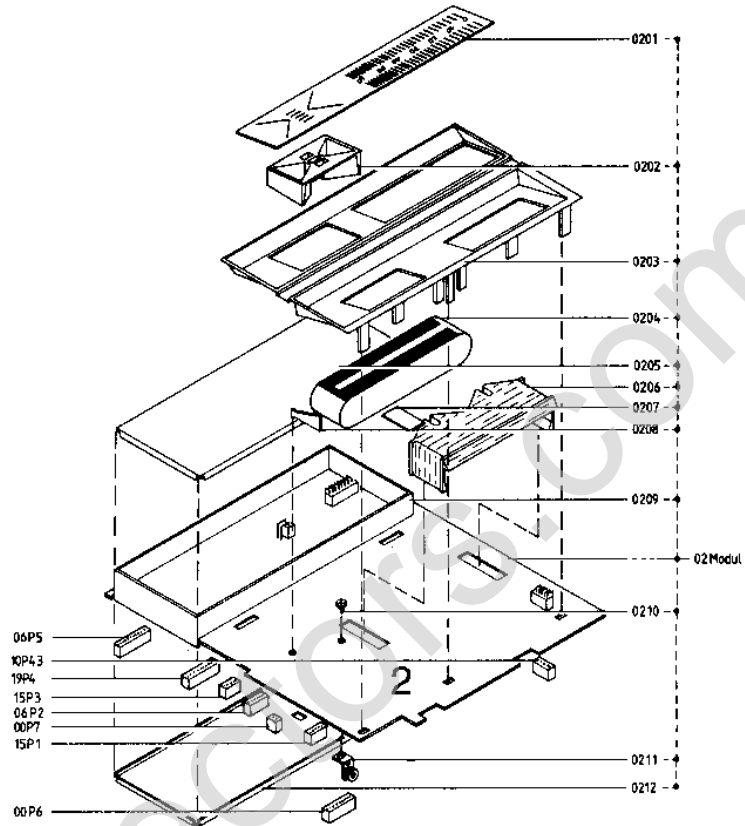

02Modul	8002522	PC2, Microcomputer	0207	3152110	Cord holder
0201	3199059	Dial		3947100	Tape
0202	3300086	Screen for tuning indicator	0208	3300086	Holder
0203	3300084	Screen for display	0209	3302336	Screen
0204	3946029	Dial ribbon	0210	2039026	Screw AM 3 x 4 DIN 7985
	3947099	Tape	0211	2530415	Bracket
0205	3302328	Screen, top	0212	3302333	Screen, bottom
0206	3190082	Light conductor with tape			
	3947091	Tape			

00P6	6275461	Wire bundle with plug	00P7	6274038	Lead with plug
	7500114	Contact pin		7500161	Contact pin
06P2	6275460	Wire bundle with plug	06P5	6275460	Wire bundle with plug
	7500114	Contact pin		7500161	Contact pin

10P43	6273963	Wire bundle with plug
	7500161	Contact pin

15P1	6273960	Wire bundle with plug
15P3	6273961	Wire bundle with plug
	7500161	Contact pin

19Modul	6275469	Main wire bundle
19P4	7210330	Socket/housing 11 poi
	7500161	Contact pin

Beomaster Terminal

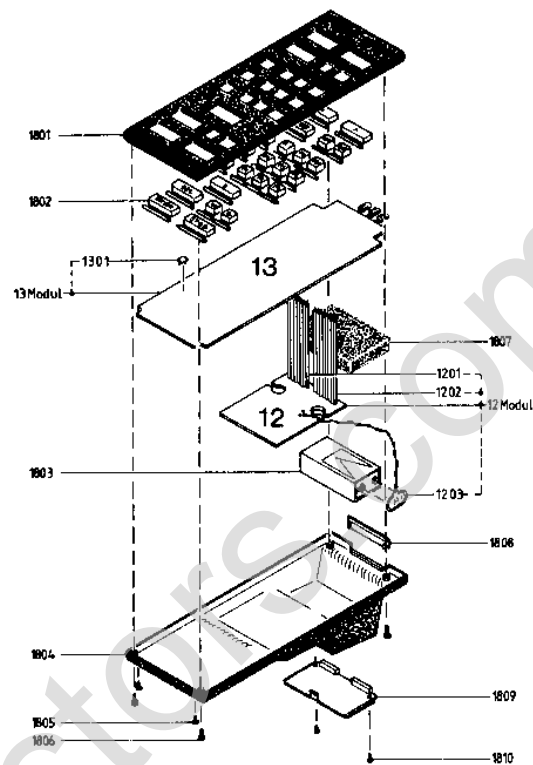

12Modul	8002496	PC12, Remote Transmitter
1201	6200016	Set of wires - 7 leads
1202	6200036	Set of wires - 8 leads
1203	7229020	Battery connection

13Modul	8002484	PC13, Remote Keyboard
1301	7500148	Contact spring

18Modul	8052139	Beomaster Terminal, complete
1801	3164464	Cover
1802	2775887	Set of buttons
1803	8700008	Battery 9V
1804	3454289	Bottom
1805	3010007	Rubber foot
1806	2011023	Screw 2.2 x 6.5 mm DIN 7981
1807	3917036	Foam
1808	3322058	Window
1809	3160031	Cover
1810	3010007	Rubber foot

4-9

Bang & Olufsen

Parts Not Shown

3532153	Instruction diagram	6270222	Signal lead
3532154	Instruction diagram for type 2254	7220252	Connector accessories
3540005	Instructions for installation of remote control receiver	3391626	Outer carton
3955035	Dial cord	3397461	Foam packing (complete)
3152214	Wire binder	3917044	Foam
3152178	Wire holder	3946015	Plastic foil
6271143	Mains lead with plug for type 2251-2252	3391630	Packing for Beomaster Terminal
6271168	Mains lead with plug for type 2253	3390001	Plastic bag for Beomaster Terminal
6271119	Mains lead with plug for type 2254		

7220265 - plug f. "external" socket

Survey of Packings for Module Transport

Module No.	Designation	Packing No.	Remarks
02	Microcomputer	3391576	To be packed in bag with protection against static electricity
03	Tone Control and Switch	3391576	To be packed in bag with protection against static electricity
04	FM-Tuning	3391574	
06	Motor Control	3391574	
07	Riza-Amplifier	3391574	
08	FM	3391575	
09	Output Amplifier	3391571	
11	Fuse and Relay	3391574	
14	Remote Receiver	3391574	
16	Power Supply	3391575	
17	Socket Panel	3391577	

GUIDE TO ADJUSTMENTS

In the following adjustments references are made to some test points (TP). It is pointed out that in a number of receivers manufactured these test points are not shown on the component print of the PC-units.

In those cases where identical adjustments are to be made for the right-hand and for the left-hand channels, the following applies: Component nominations without brackets indicate the right-hand channel whereas component nominations in brackets refer to the left-hand channel.

Adjustments indicated by a * are accessible through the bottom plate of the set (this, however, does not apply to the initially produced sets).

No-Load Current

No-load current adjustments are to be made while the receiver is in a cold state and with the volume control turned down. Loudspeakers must not be connected.

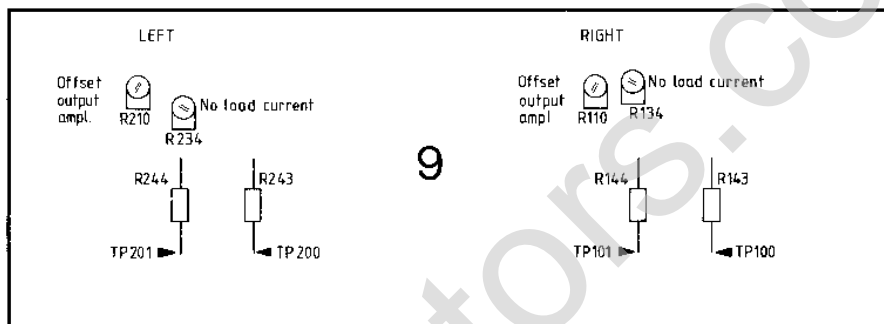

Connect a DC millivoltmeter across the two emitter resistors 9R143/9R144 (9R243/9R244) in TP100/TP101 (TP200/TP201). Adjust with 9R134 (9R234) until a reading of 22 mV is obtained.

It is also possible to make this adjustment by inserting a milliammeter in series with the collector of 9IC103 (9IC203) and adjust until a reading of 50 mA is obtained.

Offset Output Amplifier

Make these adjustments with the volume control turned down and after the receiver has been ON for at least 30 seconds. Adjust with 9R110 (9R210) until a reading of 0V (± 5 mV) on the loudspeaker output.

Tuning Voltage

Bottom:
Activate P and set P MANUAL TUNING to 87.5 MHz. Connect a DC voltmeter to 8TP19. Adjust 8R66 until a reading of 3.55V is obtained.

Top:
Set P MANUAL TUNING to 108 MHz. Adjust 8R64 until a reading of 19.7V is obtained in 8TP19.

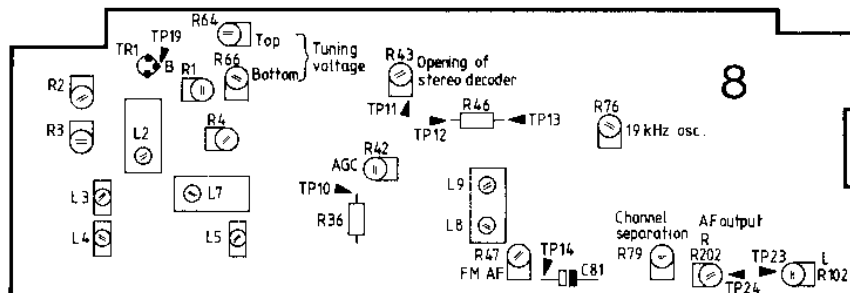

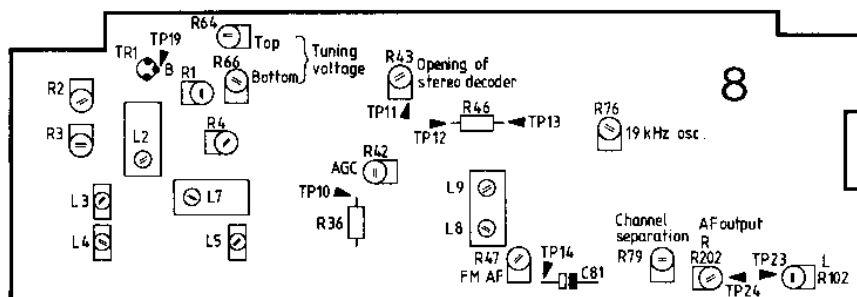
**Tuner and IF-Section**

Set P MANUAL TUNING to 87.5 MHz.

Tuner/IF

Connect a sweep generator to the aerial input and set it to 87.5 MHz.
Connect an oscilloscope to 8TP11 via an RC-probe.
Adjust with 8L2, 8L3, 8L4, 8L5 and 8L7 for maximum and symmetrical IF-curve (repeat this procedure, if necessary).

Now set the receiver and the sweep generator to 108 MHz. Adjust with the potentiometers 8R1, 8R2, 8R3 and 8R4 for maximum and symmetrical IF-curve.

Detector

Among the instruments to be used in order to make a correct adjustment of the detector, a distortion meter is required as described in point 1. If a distortion meter is not available, it is possible to make a fairly good adjustment by following the procedure described in point 2.

1. Set the receiver to, e.g. 94 MHz.

Connect a combination signal generator/sweep generator to the aerial input and set it to yield 1 mV EMF, $\Delta \pm 75$ kHz.
Set the frequency of the signal generator to 94 MHz and to minimum the 2nd harmonic of the signal (see diagram).



Connect a distortion meter to the loudspeaker output.
Connect a DC voltmeter between 8TP13 and 8TP12.
Adjust with 8L8 until the minimum distortion is measured.
Next adjust with 8L9 until a reading of 0V is obtained.
Repeat both adjustments until they are OK.

2. Make the adjustment by means of the »S-curve«, but it will always remain uncertain whether the receiver is within its distortion data.

Set the receiver to, e.g. 94 MHz.
Connect a combination signal generator/sweep generator to the aerial input and set it to yield 1 mV EMF, $\Delta \pm 75$ kHz.
Set the frequency of the signal generator to 94 MHz and to minimum the 2nd harmonic of the signal (see diagram).



Set the generator to sweep.
 Connect an oscilloscope to 8TP14 and connect a DC voltmeter between 8TP13 and 8TP12.
 Adjust with 8L8 and 8L9 for maximum and symmetrical S-curve.
 Adjust with 8L9 until a reading of 0V is obtained.

FM-AF Output

Connect a signal generator to the aerial input and set it to, e.g. 94 MHz and to yield 1 mV EMF, $\Delta \pm 75$ kHz.
 Set the receiver to the same frequency as the signal generator and in the MONO mode.
 Connect an AC voltmeter to 8TP24.
 Turn 8R202 fully up.
 Adjust 8R47 until a reading of 0.7V is obtained.
 Connect an AC voltmeter to 8TP23 and note the voltage reading.
 Reconnect the AC voltmeter to 8TP24 and adjust 8R202 until the same voltage is measured in 8TP24 as in 8TP23.

* (By the way, 8R102 (8R202) are adjustable to an output level as required by the customer).

AGC

Connect a signal generator to the aerial input and set it to, e.g. 94 MHz and to yield 1 mV EMF, $\Delta \pm 75$ kHz.
 Set the receiver to the same frequency as the signal generator.
 Connect a DC voltmeter to 8TP10.
 Adjust with 8R42 until a reading of 3.5V (± 0.2 V) is obtained.

Signal Strength Indicator

Connect a signal generator to the aerial input and set it to, e.g. 94 MHz and to yield 1 mV EMF, $\Delta \pm 75$ kHz.
 Set the receiver to the same frequency as the signal generator.
 Adjust 6R11 until the top red LED is just glowing.

Opening of Stereo Decoder

Connect a signal generator to the aerial input and set it to, e.g. 94 MHz and to yield 25 μ V EMF, $\Delta \pm 75$ kHz.
 Set the receiver to the same frequency as the signal generator.
 Connect a DC voltmeter to 8TP22.
 Adjust with 8R43 until a reading of 0.6V is obtained.
 Note: The channel separation will then be 10 dB (± 2 dB).

Stereo Decoder

In order to make this adjustment correctly a frequency counter is required or a Bang & Olufsen Voltmeter RV11 and a Frequency Probe PF5, as described in point 1. If these instruments are not available, a fairly good adjustment is possible by following the procedure as described in point 2.

1. Solder a 220 kohm resistor from the base of 8TR14 to +15V.
 Tune the receiver to a MONO station.
 Connect a frequency counter (or RV11/PF5) to 8TP16.
 Adjust with 8R76 until a reading of 19 kHz ± 50 Hz is obtained.
 After the adjustment is finished, remove the soldered-on resistor.

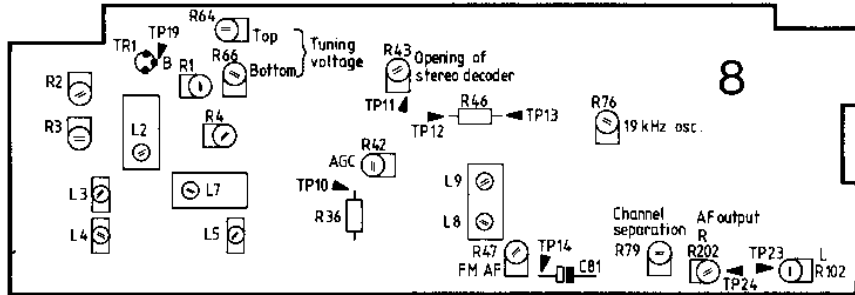

2. Solder a 220 kohm resistor from the base of 8TR14 to +15V.
Tune the receiver to a STEREO station.
Turn the potentiometer 8R76 anti-clockwise (as seen from the component side) until the stereo effect just ceases to be heard. Then turn 8R76 clockwise until the stereo effect just ceases to be heard. Now adjust 8R76 exactly between the two positions and an approximately correct adjustment has been achieved.
After the adjustment is finished, remove the soldered-on resistor.

Channel Separation

Connect a stereo encoder to the aerial input.
Connect a wattmeter or an AC voltmeter to the loudspeaker output.
Adjust with the potentiometer 8R79 until minimum signal is achieved in the unmodulated channel.

FM Light Balance

- * 1. Balance.
Connect a DC voltmeter between 8TP12 and 8TP13.
Tune to a station and adjust to 0V between 8TP12 and 8TP13.
Adjust 6R3 until equal light strength is obtained in the two balance arrows.
2. Strength.
Connect a DC voltmeter to the collector on 6TR9, and adjust 6R51 until a reading of 7.5V is obtained on the collector of 6TR9.

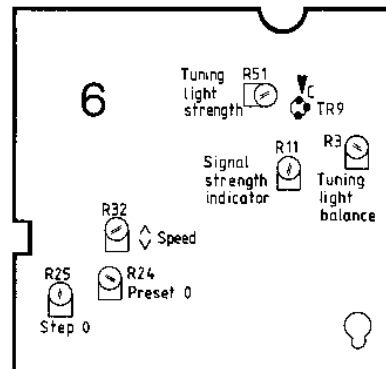

Volume Control

Connect a DC voltmeter across the motor with 0 on 5TP20 and plus on 5TP21.

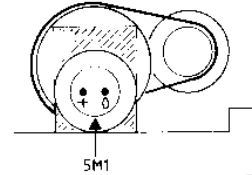
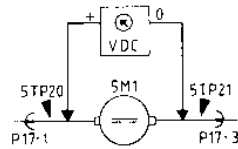

1. Volume step 0:

By activating step 30 and then step 0 respectively, adjust 6R25 until the motor bottoms the volume potentiometer at step 0. (In the 0 position the voltage across the motor must be between 0 and +1V).

2. Preset volume 0:

Activate reset.

By regulating the Preset volume potentiometer towards max. and 0 respectively, adjust 6R24 until the motor bottoms the volume potentiometer at position 0.

(In the 0 position the voltage across the motor must be between 0 and +1V).

After Preset volume 0, check step 0.

★ 3. VΛ volume speed:

While activating VΛ, adjust 6R32 until the voltage across the motor is 6.5V or to a motor speed as required by the customer.

Reset

During this adjustment, pay attention to static electricity.

Make this adjustment without having the receiver connected to the mains.

Remove P5 on module 2.

Connect a variable DC power supply with - to chassis and + to pin 3-4 on P5.

Set the power supply to yield +4.6V (voltmeter controlled).

Set an oscilloscope in DC mode and connect it across 2R95.

Adjust 2R89 until a reading of $2.3V \pm 1V$ is obtained across 2R95.

Please note that this adjustment is extremely sensitive.

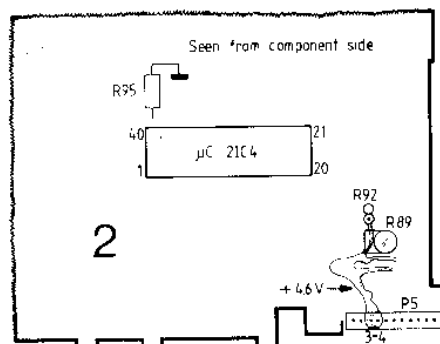

6-1

Bang & Olufsen

ELECTRICAL DESCRIPTION Silent Tuning

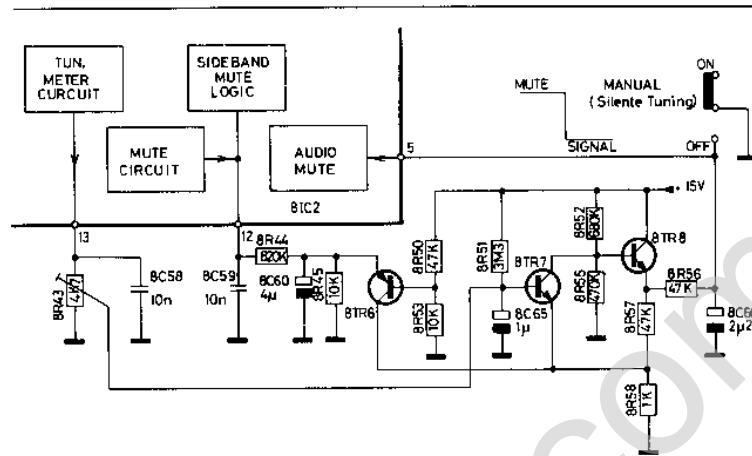

8IC2

Pin 13: Rising signal strength = rising potential
Falling signal strength = falling potential

Pin 12: On sideband = high. On station and noise = low.

MANUAL in ON position.

8TR7 is ON at strong signals and pulls the base of 8TR8 down. 8TR8 is OFF and a path is opened to chassis from pin 5 on 8IC2 via 8R56, 8R57 and 8R58 which results in signal passage.

When the signal has dropped to a certain level, 8TR7 goes OFF and 8TR8 goes ON. Pin 5 on 8IC2 goes high, and the signal is being muted.

Pin 12 on 8IC2 is high if you tune away from a station while tuning on the side band. When pin 12 is high, 8TR6 goes ON.

This raises the level on the emitter of 8TR7, and 8TR7 goes OFF. 8TR8 goes ON and the signal is being muted.

When MANUAL is in OFF position, a path is opened to chassis from pin 5 on 8IC2, and all types of signals will pass.

Tuning and AFC

Tuning can be made with the P MANUAL TUNING wheel or with one of the six pre-set programmes.

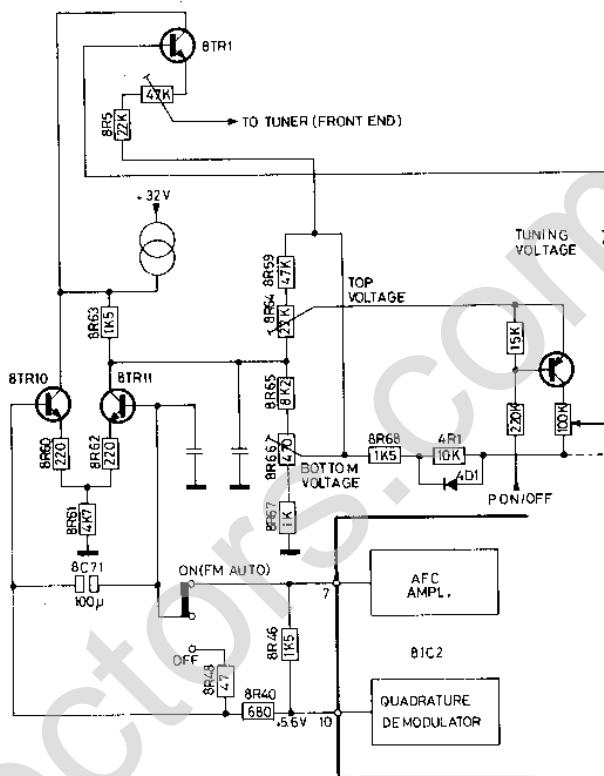

The tuning system is supplied from +32V via a constant-current generator. The bottom voltage is adjustable with 8R66 and the top voltage with 8R64.

AFC

The base of 8TR10 is connected to pin 10 of 8IC2 which has a stable DC voltage of approx. 5.6V. When the AFC is engaged (FM AUTO) the base of 8TR11 is connected to pin 7 of 8IC2.

When the receiver is tuned accurately to a station, the voltage on pin 7 of 8IC2 is also approx. 5.6V. When tuning down from the centre of the station the voltage on pin 7 of 8IC2 will be falling. The current in 8TR11 will be falling and the voltage on its collector will be rising. The tuning voltage will also be rising and the station will be pulled in until pins 7 and 10 of 8IC2 are again in balance. When tuning up from the centre of a station the voltage on pin 7 of 8IC2 will be rising, the tuning voltage will be falling and the station will be pulled in accurately.

The holding range of the AFC is ± 200 kHz.

When the AFC is OFF, pin 7 of 8IC2 is drifting and the bases of 8TR10 and 8TR11 are short-circuited via 8R48.

6-3

Bang & Olufsen

Fault Switch

The function of the circuit is to protect connected loudspeakers against overloads at faults in the output amplifier and to protect the output amplifier thermally at too high loads.

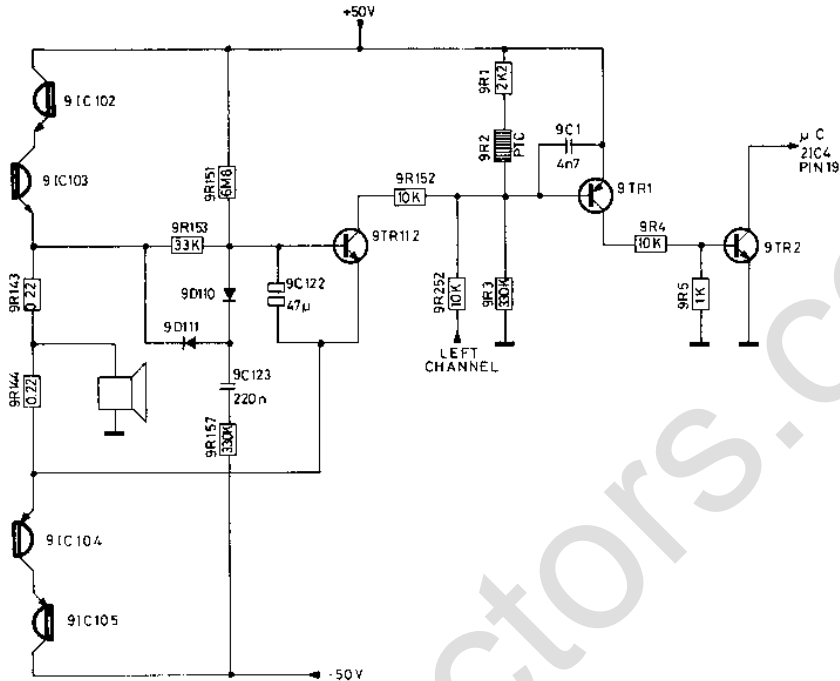

A voltage swing (a signal) on the output will charge 9C122 to a negative voltage via 9D111, 9C123, 9D110, and the resistor 9R157 which is limiting the charging.

Current through the emitter resistors will result in a voltage drop across the latter.

This voltage drop will charge 9C122 to a positive voltage through 9R153 or the emitter on 9TR112 to a negative voltage.

This negative and positive charging of 9C122 will during normal operation (8 ohm load) neutralize each other with the result that 9TR112 is not forward biased. The base-emitter voltage on 9TR112 will appear from the below table under varying operational conditions.

Output load	Voltage swing	Current	Base-emitter voltage on 9TR112
8 ohm	small	small	0
none	small	none	negative
2 ohm	small	high	+0.6 V after some time at high strength
short-circuited	none	high	+0.6 V instantaneously

When 9TR112 is forward biased, the base on 9TR1 is pulled low. 9TR1 and thus 9TR2 will go ON, pin 19 on the microcomputer will be pulled low, and the receiver will go in ST.BY mode.

A PTC resistor (9R2) is used to protect the cooling grill against overheating. It is fitted adjacent to the grill. With rising temperatures the resistance in 9R2 will also rise. When the resistance of 9R2 has reached a certain level, 9TR1 and thus 9TR2 will go ON, and the receiver is in ST.BY mode.

FM Frequency Counter

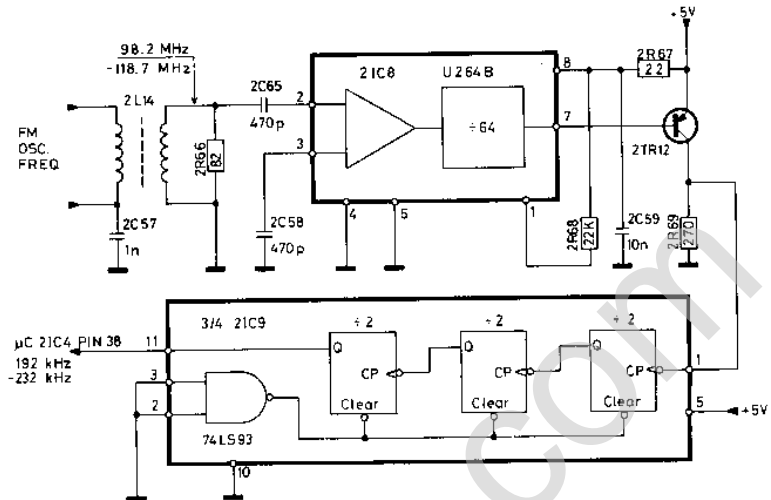

The FM oscillator frequency is being counted by the microcomputer which internally subtracts the intermediate-frequency ratio from the oscillator frequency with the result that the correct aerial frequency can be read out on the display.

Via 2L14 (which ensures galvanic separation between tuner and counter frequency) the oscillator frequency is transferred to 2IC8. 2IC8 has the dual function of amplifier and sub-divider. Sub-division is necessary since the microcomputer cannot count frequencies above 500 kHz. After amplification and division by 64 in 2IC8 the frequency is further amplified in 2TR12 and applied to 2IC9.

In 2IC9 the frequency is further divided by 8 in 3 trailing-edge flip-flop units so that totally it is divided by 512. The frequencies which are applied to the frequency of the microcomputer may vary from 192 kHz to 232 kHz.

6-5

Reset

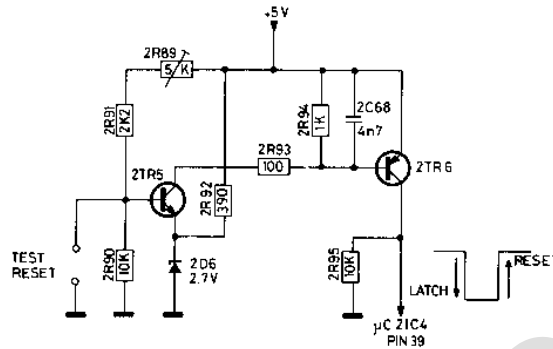

In order to inhibit the microcomputer from locking to a random internal program during start-up of the power supply or after a mains dropout of a duration of more than 1 second (cf. microcomputer power back-up), the above circuit has been incorporated.

During normal operation 2TR5 and thus 2TR6 are ON and pin 39 on 21C4 is HIGH. If the 5V power supply is dropping, 2TR5 and 2TR6 will go OFF when the voltage has dropped to 4.67V. At 4.67V the microcomputer will lock-out the program it is processing at the moment and it will remain locked until the voltage has dropped down to the undefined range of the microcomputer lower than 4.5V, typically 3-3.5V. At rising voltage the microcomputer will be operational when the voltage reaches 4.5V, but nothing will happen until the voltage reaches 4.67V which is when 2TR5 and 2TR6 will go ON, pin 39 on the microcomputer will go HIGH and it will be reset. After the reset the microcomputer will run through its start-up routine and go in ST.BY mode.

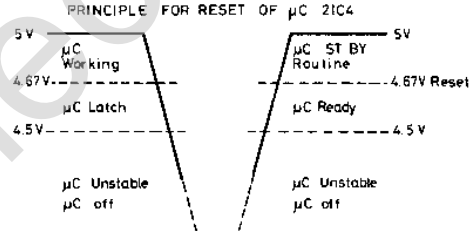

The circuit can be adjusted by means of 2R89.

It is possible to reset the microcomputer manually by for a short while to short-circuit the points marked TEST RESET.

μC Power Back-up

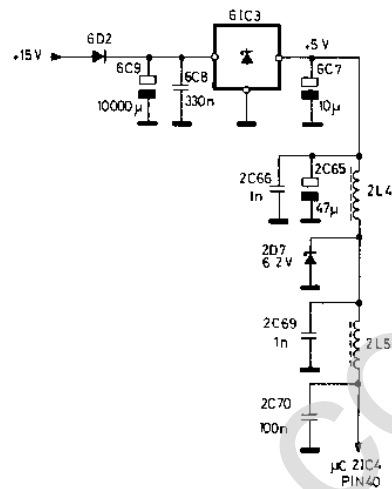

The microcomputer is powered from +15V via a 5V stabilization IC (61C3). 6C9 (10,000 μF) is the power back-up for the microcomputer which means that the microcomputer will not go in reset mode by mains dropout of short duration (at mains dropout from rated 220V of less than 1 second duration).

Time-base for μC

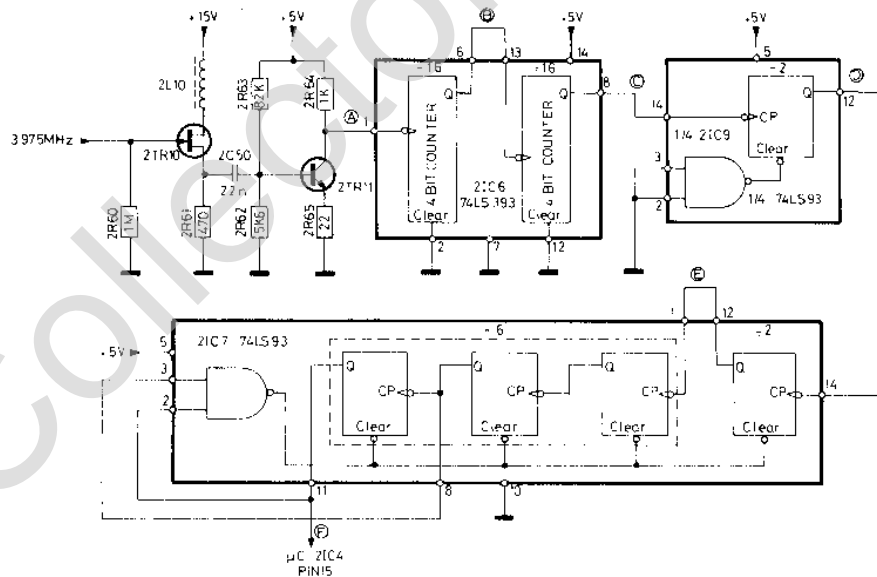

A	3.975 MHz
B $\frac{A}{16}$	248.4 kHz
C $\frac{B}{16}$	15.5 kHz
D $\frac{C}{2}$	7.75 kHz
E $\frac{D}{2}$	3.9 kHz
F $\frac{E}{8}$	647 Hz

(not sym)

Since the internal timer of the microcomputer is utilized as a counter to determine the FM oscillator frequency, an external pulse rate frequency must be used to code the microcomputer. This frequency is produced by subdividing the crystal frequency 6,144 times.

The time-base frequency is 647 Hz and unsymmetrical.

The 5R6 (VOLUME SLAVE) potentiometer is integral with the volume potentiometer and, consequently, it is also driven by 5M1.

In, for instance, ST. BY mode all outputs on 6IC6 are high except pin 9 which is low. If the lever on 3R4 (PRESET VOLUME) potentiometer is in its bottom position, the voltage on the anode of 6D5 is clamped to chassis via 6R27, 6R24 and 6IC6. Then 5M1 is in »down volume«, the lever on 5R6 in the bottom position and the voltage of the anode of 6D4 is clamped to chassis via 6R25, 6R53 and 6TR7.

If the lever on 3R4 is moved upwards, the voltage on the anode of 6D5, and thus pins 6 and 8 on 6IC5, will rise towards 15V.

Since the voltage on the anode of 6D4 is low, pins 7 and 9 on 6IC5 will also be low. This will have the consequence that pin 13 on 6IC5 will be chassis going and pin 2 will be positive-going and the voltage across the motor will rise to a potential where the motor will begin to run, the lever on 5R6 will be pulled upwards and pins 7 and 9 on 6IC5 will be positive-going. If the lever on 3R4 is stopped, the motor will continue to run until the voltage on pins 7 and 9 on 6IC5 has reached a level where the outputs pins 2 and 13 are in balance with the consequence that the voltage across the motor will drop so much that the motor will stop.

In principle, turning the volume down takes place in the same way as turning it up with the only difference that the voltage on pins 6 and 8 on 6IC5 will be decreasing and that pins 7 and 9 will have positive weight with the consequence that the voltage across the motor is reversed in relation to turning the volume up.

When pressing one of the volume step buttons the appropriate output on 6IC6 will go low while all other outputs on 6IC6 will remain high. When pin 9 on 6IC6 is high, the setting 3R4 has no influence on the regulation.

In principle, the step regulation is made in the same way as the PRESET regulation with the only difference that the voltage division between 6R47 and 6R41, 42, 43, 44, 45, 46 respectively will replace 3R4. The approximate voltages for the various steps (measured on the cathode of 6D8) will appear from the below table.

STEP	VOLT
0	1
10	5
20	7
30	8,8
40	10
50	11,5
60	15

VΛ Adjustment

When pressing for instance Λ, pin 11 on 6IC6 will go low while all other outputs and the input on pin 12 will go high. When pin 12 goes high, the base bias of 6TR7 will be shorted to chassis, and the setting of 5R6 will have no influence. With a low level on pin 11 on 6IC6, a path is opened between pins 8 and 6 on 6IC5 and chassis via 6R38. Likewise, a path is opened between pins 9 and 7 to chassis via 6R33 and 6R32 which combined make up a greater resistance than 6R38. This will have the consequence that pins 9 and 7 on 6IC5 have positive weight relative to pins 8 and 6 and that 5M1 will turn the volume up with a speed which is adjustable with 6R32. When the Λ button is no longer pressed, pin 11 on 6IC6 will go high, the circuit will balance out and 5M1 will stop.

The V adjustment is made in the same way as Λ with the only difference that it is pin 10 on 6IC6 which goes low.

7-1

Bang & Olufsen

DISMANTLING

Opening-up of the Receiver (Service position)

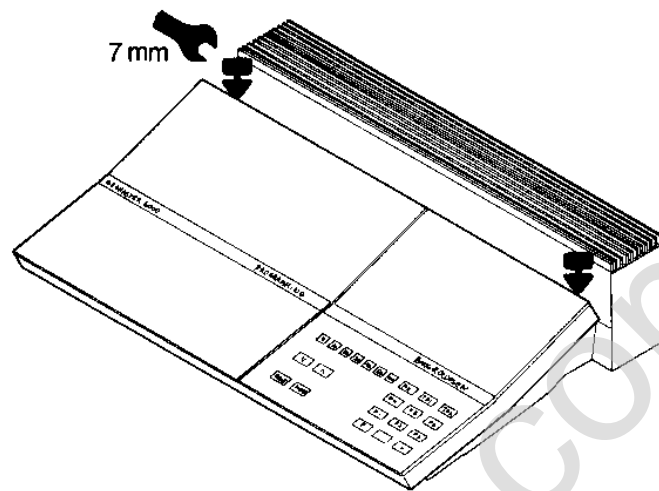

Remove the screw covers and loosen the two screws. The top part can now be lifted and put into service position.

Power Supply and Output Amplifier

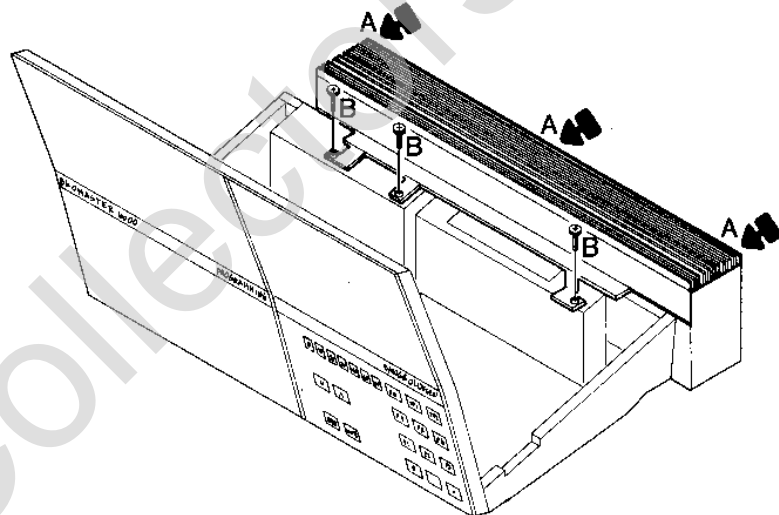

Put the receiver into service position.

Loosen screws A and remove screws B.

The cooling grill may now be removed.

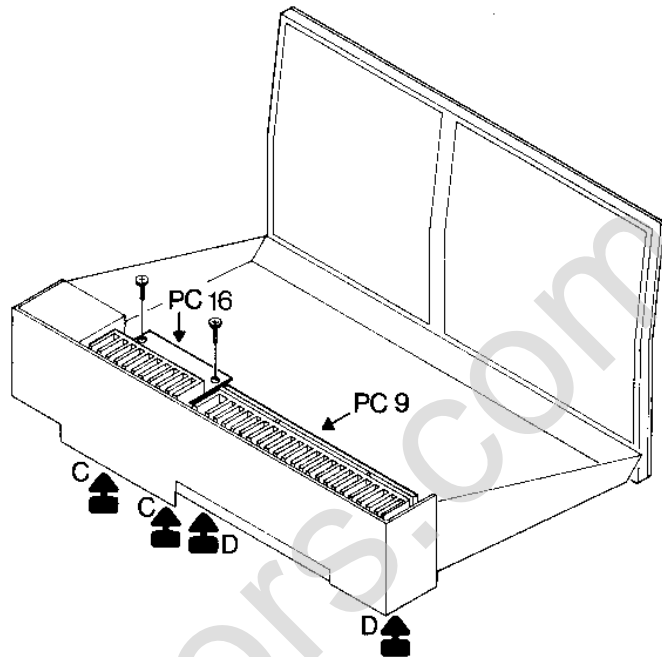

Loosen screws C and remove the two screws on top of PC16. The power supply may now be removed.

Loosen screws D and the output amplifier PC9 can be removed.

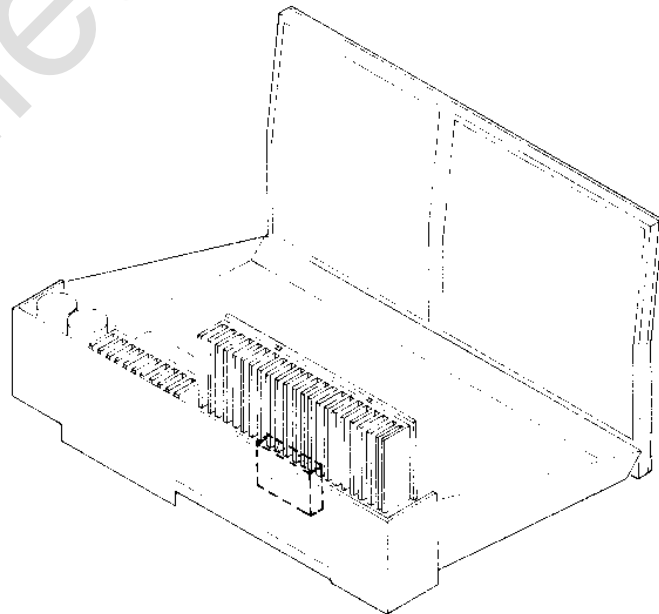

The foam block placed over the electrolytic capacitors of the power supply may be used as support during measurements in the output amplifier. The whole component side will then be accessible for measurements.

7-3

Bang & Olufsen

Operating Panel

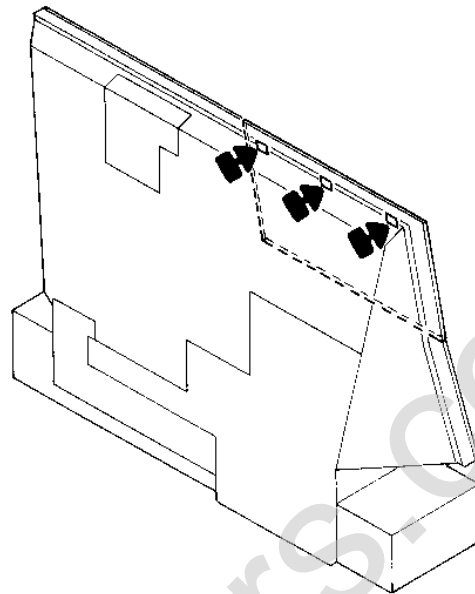

Loosen the 3 locking pins with a fine screwdriver after which the operating panel can be lifted at the front edge and pulled upwards.

Dial Glass Plate

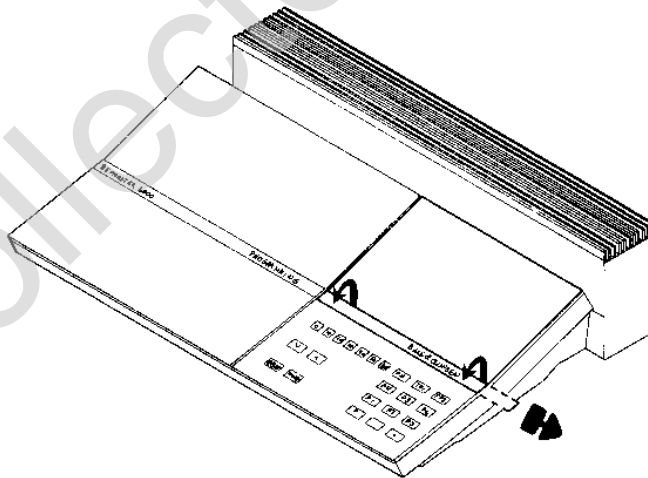

Push the decorative profile between the glass plate and the operating panel to the right and remove it. Lift the glass plate at the front edge and pull it outwards.

Programme Lid and Secondary Operating Panel

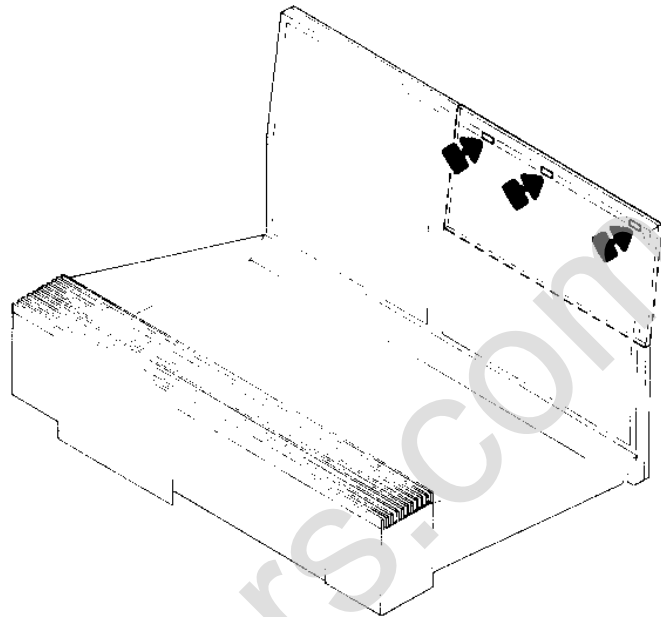

With the top part in the service position the 3 locking pins can be loosed with a screwdriver, and the panel with lid can be pulled up.

REMEMBER: The pushbuttons on FM and Loudness Switch are loose.

Socket 3P43 must be removed if the panel is removed altogether.

Aluminium Cover Plate

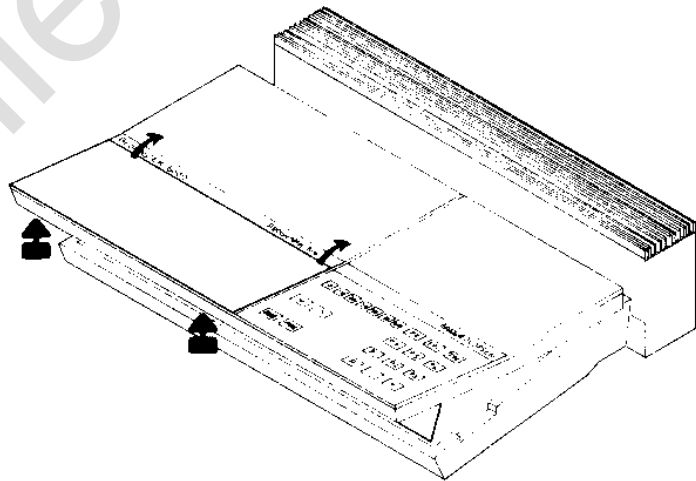

Place the receiver at the edge of a table.

Loosen the top part and pull it forward so that the 2 screws are accessible from below. Loosen the screws and lift the aluminium plate up at the side at the eject rail and pull backwards.

Note: If the receiver has not been dismantled, the screws can be loosened through holes in the bottom plate.

7-5

Bang & Olufsen

Socket Panel

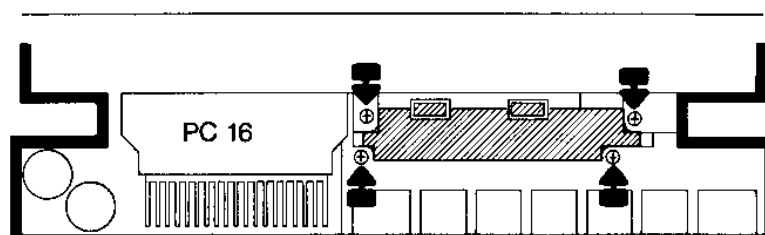

Set the top part into service position, remove the cooling grill and lift up the output amplifier. The 4 screws can now be removed.

Place the receiver on its rear edge and pull the output amplifier upwards.

The socket panel can now be removed downwards.

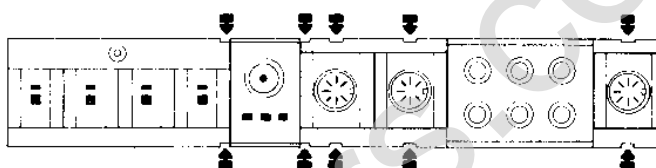

For replacement of DIN and FM sockets the terminals at the rear of the PC plate can be de-soldered and the socket clipped loose through the holes in the angle.

TECHNICAL SPECIFICATIONS	BEO MASTER 6000
Type no.	2251-2252-2253-2254
Standard for measurements	IHF
Continuous power output per channel	75 watts at 8 ohms
Rated bandwidth	20-20,000 Hz
Total harmonic distortion	<0.08%
Dynamic headroom	0.7 dB
IHF intermodulation	<0.05%
Response vs frequency:	
Phono	20-20,000 Hz \pm 1.5 dB
Tape	20-20,000 Hz \pm 1.5 dB
Wideband damping factor	60
Input sensitivity/Impedance:	
Phono	0.22 mV/47 kohms
Tape	22 mV/200 kohms
Line	500 mV/15-47 kohms (at specified power output)
Overload level:	
Phono	80 mV
Tape	8 V
Signal-to-noise ratio:	
A-weighted phono	>75 dB
A-weighted tape	>78 dB
Channel separation	50 dB
Output:	
Tape	530 mV/1 kohms
Line	500 mV/1 kohms
Headphones	Max. 14 V/200 ohms
Bass control at 40 Hz	\pm 11 dB
Treble control at 12,500 Hz	\pm 11 dB
FM range, type 2251-2252-2253	87.5 - 108 MHz
FM range, type 2254	76.9 - 88.7 MHz
FM aerial impedance	75 and 240 ohms
Usable sensitivity mono	15 dBf - 1.5 μ V/75 ohms
Usable sensitivity stereo	17 dBf - 2 μ V/75 ohms
50 dB quieting sensitivity mono	21 dBf - 3 μ V/75 ohms
50 dB quieting sensitivity stereo	40 dBf - 28 μ V/75 ohms
Signal-to-noise ratio at 65 dBf mono	77 dB
Signal-to-noise ratio at 65 dBf stereo	71 dB
Stereo channel separation at automatic channel blend	40 dB
Frequency response	20-15,000 Hz \pm 1 dB
Distortion at 65 dBf mono	0.2%
Distortion at 65 dBf stereo	0.3%
Intermodulation distortion mono	0.02%
Intermodulation distortion stereo	0.18%
Capture ratio	1.8 dB
Adjacent channel selectivity	6 dB
Alternate channel selectivity	65 dB
Spurious response	110 dB
Image response ratio	86 dB
IF response ratio	120 dB
AM suppression	63 dB
Subcarrier product rejection	72 dB
Power supply	type 2251 220 volts
	type 2252 240 volts
	type 2253 120 volts
	type 2254 100 volts
Power frequency	50-60 Hz

8-2

Bang & Olufsen

Power consumption	50-320 watts
Dimensions W x H x D	52.5 x 15 x 38 cm
Weight	14 kg

Subject to change without notice

BeoCollectors.com

INSULATION TEST

Each receiver **must** be insulation tested after having been dismantled. The test is to be made when the receiver has been reassembled completely and is ready for delivery to the customer.

Insulation Test for Beomaster 6000

Make the insulation test as follows:
Short-circuit the two plug pins of the mains plug and connect them to one of the terminals of the insulation tester. Connect the other terminal of the insulation tester to the chassis screw which is to be found above the loudspeaker sockets at the rear of the receiver.

NOTE!

To avoid ruining the receiver it is essential that both insulation tester terminals are in really good mechanical contact.

Now turn slowly the voltage control of the insulation tester until a voltage of 1.5-2 kV is obtained. Hold it there for 1 second, then turn the voltage down again slowly.

The terminals of the insulation tester may now be disconnected.

At no point during the testing procedure any flash-overs are permissible.

10-1

Bang & Olufsen

FINAL TESTING

By following the below instructions all receiver functions are tested. The sequence in below table **must** be adhered to.

Pre-setting:
MANUAL
PRESET VOLUME 0

OPERATION	FEED-BACK	
	DISPLAY	INDICATORS
PUSHBUTTON operation		
Connect to mains	Decimal point (ST. BY)	
P	Follow keying, e.g. 94.4 P	Balance arrows and background for volume scale
PRESET VOLUME to max. and then to 0		Volume scale follows operation
0 10 20 30 40 50 60 √ ^		Volume scale follows operation
RESET		Volume scale to 0
P MANUAL TUNING in outer positions	Minimum 87.5-108.0 P	When station is passed: Field strength, stereo at MPX, balance light follows tuning station
P1 → P6 At the same time test the potentiometers involved	Follows keying e.g. 94.4 P6 Follows regulation	
PH ⇒ TP1 ⇒ TP2	PH ⇒ TP1 ⇒ TP2	
ST. BY (●)	Decimal point	
CLOCK SET	Time from connection e.g. 00:02 (colon flashing)	
Four times 8	88:88 (colon flashing)	
Real time ⇒ OK	Real time ⇒ Decimal point	
P1	Follows keying e.g. 94.4 P1	
FREQ ↓ ↑ two times CLOCK	1. Real time (colon constant) 2. e.g. 94.4 P1	
TIMER 1	00 00 (the two first digits are flashing)	

OPERATION	FEED-BACK	
PUSHBUTTON operation	DISPLAY	INDICATORS
TIMER 2	00 00 (the two rear digits are flashing)	
A random point in time ⇒ OK ⇒ ST. BY	Point in time selected ⇒ e.g. 94.4 P1 ⇒ : .	

Connect:

4 x loudspeaker.

Headphone.

GR 6000 or 8000 to PHONO } DATA LINK

BE 6000 or 8000 to TAPE 1 }

Other BE to TAPE 2.

Make listening test on all programmes.

Test DATA LINK.

Test balance, bass, treble, loudspeaker switches, FM-AUTO (AFC),
MANUAL (silent tuning), MONO, LOUDN ON/OFF and MUTE.

BeoCollectors.com

11-1

Bang & Olufsen

SERVICE TIPS Dial Drive for Volume

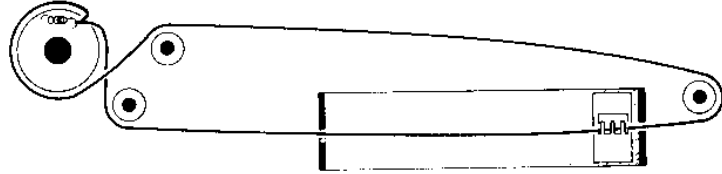

Set top part into service position.
Dial drive seen from above.
Volume motor in 0 position.
Dial in 0 position.

Dial cord, index No. 3955035.

Repairs of Volume Dial

Due to flexibility requirements the dial tape for volume must be repaired with tape, index No. 3947099, only.

Dial Drive for FM



Remove Module 04 (Preset).
Turn the tuning potentiometer anti-clockwise all the way.

Dial cord, index No. 3955034.

Replacement of 9TR102/202

At replacements in receivers with serial numbers lower than No. 2421001, a 560 ohm resistor (index No. 5010067) has to be fitted in series with the base. If this resistor is not fitted, the result may be a disharmonic sound in the loudspeakers immediately after activation of ST.BY.

Replacement of Power Supply Transformers

Put the top part into servicing position.
00T1 is accessible.
Remove Module 16 (power supply) and 00T2 becomes accessible.

Survey of Mounting of Wires on Power Supply Transformers

00T1 = 8013258
00T2 = 8013257
Module 11 = 8002462

Type 2251 = 220V

00T1 soldered for 220V

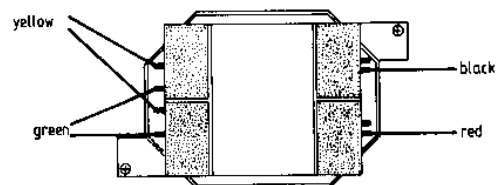

00T2 soldered for 220V

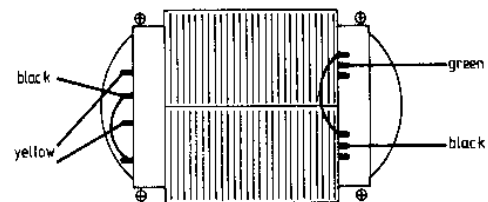

Type 2252 = 240V

00T1 = 8013258
00T2 = 8013257
Module 11 = 8002462
Rear plate label for type 2252 (240V) = 3180889

00T1 soldered for 240V

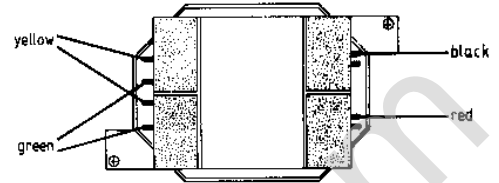

00T2 soldered for 240V

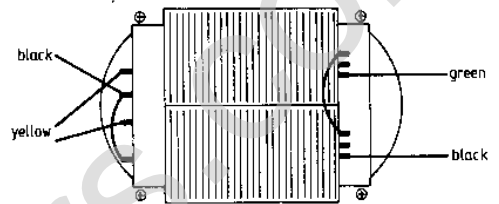

Type 2253 = 120V

00T1 = 8013271
00T2 = 8013270
Module 11 = 8002506
Rear plate label for type 2253 (120V) = 3180888

00T1 soldered for 120V

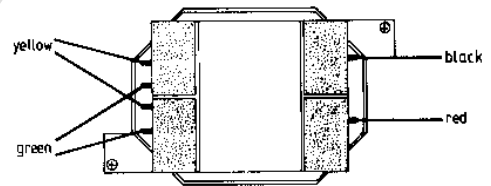

00T2 soldered for 120V

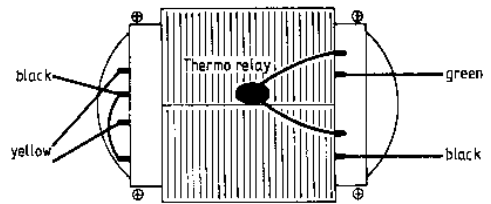

11-3

Bang & Olufsen

Type 2254 = 100V

00T1 = 8013273
 00T2 = 8013272
 Module 11 = 8002506
 Rear plate label for type 2254 (100V) = 3180890

00T1 soldered for 100V

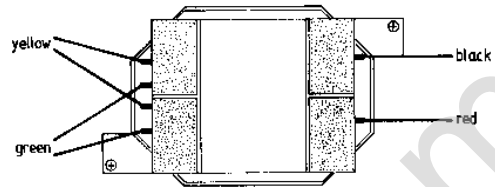

00T2 soldered for 100V

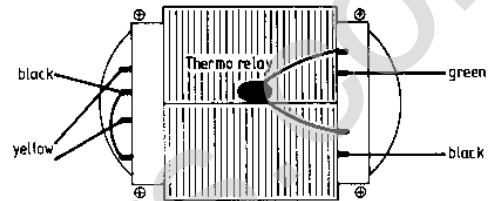

Survey of Wires

Wires from Beomaster 6000 to:	
Beocord with data link (TP1)	6270222 (7 pins – 4 signals, 2 data links)
Tape recorder with RCA phono plugs (TP1)	6270215 (DIN/PHONO, 2 x 2 signals)
Beocord without data link or another tape recorder with 5 pole DIN socket (TP2)	6270212 (PHONO/DIN with attenuator, 2 x 2 signals)
Tape recorder with RCA phono plugs (TP2)	2 off 6270236 (2 signals in each)
Beogram 8000 (PH)	6270213 (7 pins – 2 signals, 2 data links)
Equalizer with RCA phono plugs (External)	6270215 (DIN/PHONO, 2 x 2 signals)

BeoCollectors.com

BeoCollectors.com

BeoCollectors.com

BeoCollectors.com

BeoCollectors.com

BeoCollectors.com

**BANG & OLUFSEN
DK - 7600 STRUER
DENMARK**

**TELEPHONE 07 - 85 11 22* - TELEX 66529
CABLE ADDRESS BANGOLUF**

3538524

11-81

PRINTED IN DENMARK BY BOSTYKBERGÅRDEN AS, STRUER