

COLOR TELEVISION

SERVICE MANUAL

Service Manual for Punktal
14"/21" CRT TV -- 2008

CONTENTS

SAFETY INSTRUCTION AND GENERAL INSTRUCTION.....	1
ALIGNMENT ITEMS AND PROCEDURE.....	2
TEST EQUIPMENT.....	3
DEBUGGING INSTRUCTION.....	3
IC BLOCK DIAGRAM.....	9
WIRING DIAGRAM.....	15
SCHEMATIC DIAGRAM.....	16
APPENDIX: EXPLODED VIEW	

AUTION: THIS SERVICE MANUAL IS ONLY FOR PROFESSIONAL SERVICE PERSONNEL'S REFERENCE. BEFORE SERVICING THIS CHASSIS, PLEASE READ THE FOLLOWING NOTICE ITEMS.

1. SAFETY INSTRUCTION AND GENERAL INSTRUCTION

Before servicing and aligning this equipment, please read the following “**X-RAY RADIATION PRECAUTION**”, “**SAFETY PRECAUTION**” and “**PRODUCT SAFETY NOTICE**”.

1.1 X-RAY RADIATION PRECAUTION

- 1) Excessive high voltage can produce potentially hazardous X-RAY RADIATION. To avoid such hazards, the high voltage must not be above the specified limit. The normal value of the high voltage of this receiver is under 24.5kV(21”) and 22.5KV(14”) at zero beam current (minimum brightness), the high voltage must not, under any circumstances, exceed 30kV.
- 2) Each time a receiver requires servicing, the high voltage should be checked following the HIGH VOLTAGE CHECK procedure in this manual. It is recommended the reading of the high voltage be recorded as a part of service record. It is important to use an accurate and reliable high voltage meter.
- 3) The primary source of X-RAY RADIATION in this TV receiver is the picture tube. For continuous X-RAY RADIATION protection, the replacement tube must be exactly the same type tube as specified in the parts list.
- 4) Some parts in this receiver have special safety-related characteristics for X-RAY RADIATION protection. For continuous safety, parts replacement should be undertaken only after referring to the PRODUCT SAFETY NOTICE below.

1.2 SAFETY PRECAUTION WARNING:

Service should not be attempted by anyone unfamiliar with the necessary precaution on this receiver. The following are the necessary precautions to be observed before servicing this chassis.

- 1) Since the power supply circuit of this receiver is directly connected to the AC power line, an isolation transformer should be used during any dynamic service to avoid possible shock hazard.
- 2) Always discharge the picture tube anode to the CRT conductive coating before handling the picture tube. The picture tube is highly evacuated and if broken, glass fragments will be violently expelled. Use shatter proof goggles and keep picture tube away from the unprotected body while handling.
- 3) When replacing a chassis in the cabinet, always be certain that all the protective devices are put back in place, such as: non-metallic control knobs, insulating covers, shields, isolation resistor-capacitor network etc.
- 4) When replacing parts or circuit boards, disconnect the power cord.
- 5) When replacing a high wattage resistor (oxide metal film resistor) on the circuit board, keep the resistor 10mm (1/2in) away from circuit board.
- 6) Connection wires must be kept away from components with high voltage or high temperature.
- 7) If any fuse in this TV receiver is blown, replace it with the FUSE specified in the chassis parts list.

1.3 PRODUCT SAFETY NOTICE

Many electrical and mechanical parts in the chassis have special safety-related characteristics. These characteristics are often passed unnoticed by a visual inspection and the X-RAY RADIATION protection afforded by them cannot necessarily be obtained by using replacement components rated for higher wattage, etc. Replacement parts which have these special safety characteristics are identified in this manual and its supplement electrical components having such features are shaded on the schematic diagram and the parts list.

Before replacing any of these components, read the parts list in this manual carefully. The use of substitute replacement parts which do not have the same characteristics as specified in the parts list may create shock, fire, X-RAY RADIATION or other hazards.

2 Alignment items and procedure

The alignment flow chart (see below figure).

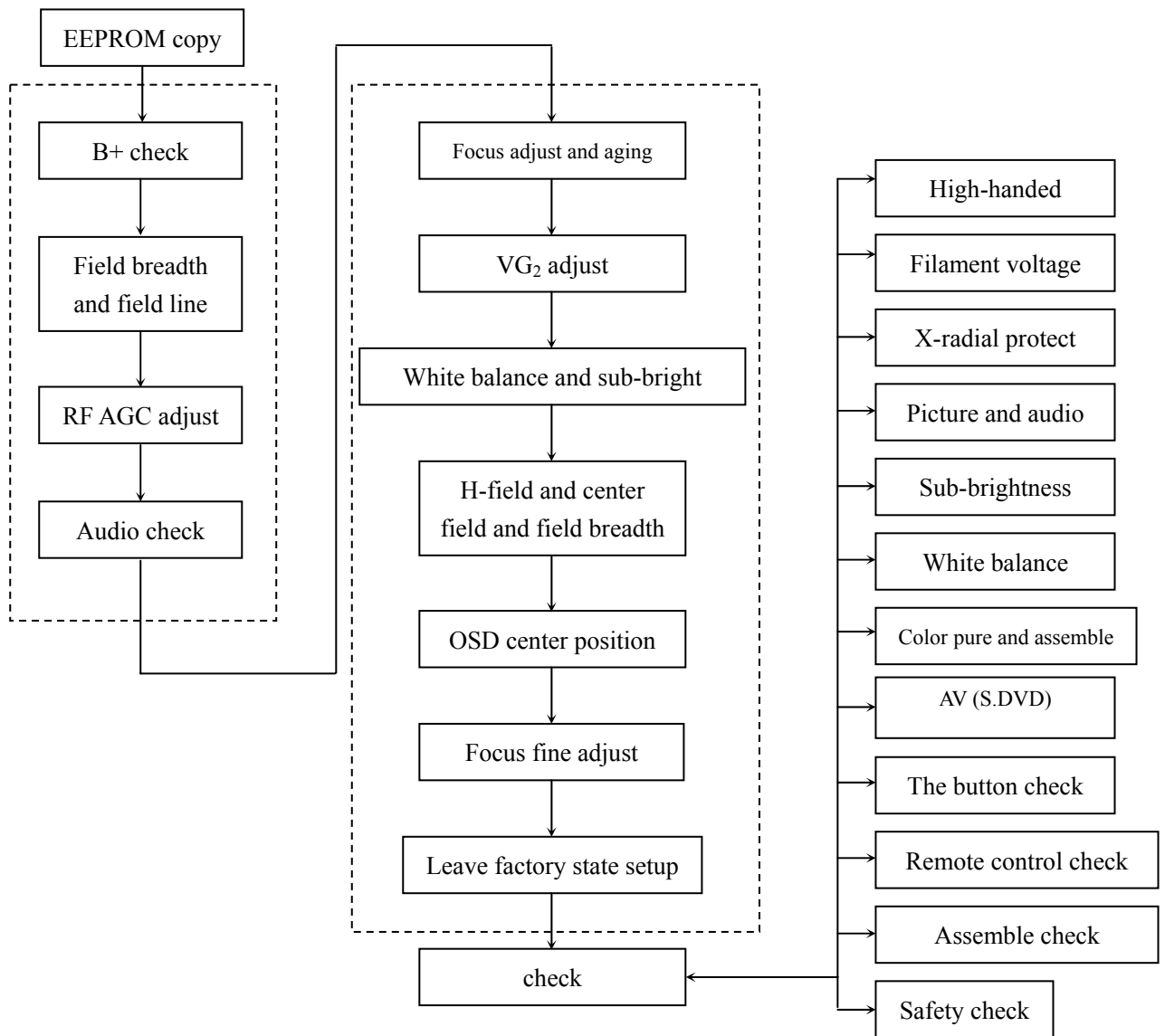

3 TEST EQUIPMENT

- 3.1 AUDIO VOLTAMETER
- 3.2 OSCILLOGRAPH
- 3.3 HIGH-VOLTAMETER
- 3.4 DIGITAL MULTIMETER
- 3.5 AC ATTACK PULL TEST EQUIPMENT
- 3.6 SCAN frequency signal generator BT-3

4 Debugging instruction

4.1 enter into the factory debugging menu

use to the remote control(RC-A23),follow to the blow model enter into the factory:

→ → → → enter into the factory

press “sleep” button for pages upward, press “return” button for pages downward, press “CH+/-” to select alignment items and “VOL+/-” to adjust volume, press “MUTE” to exit.

If the remote sensor designed for alignment is unavailable, press the following buttons to enter by using user remote sensor

4.2 B+ voltage adjustment

Check B+ voltage (negative pole of VD509) by using DC voltmeter DC 200V

CRT Model	B+	Note
A34AGT13X15(F)	106V±0.5 V	14”
A51AEZ90X09(F)	110V±1 V	21”
A51AKL13X53(M)	112V±0.5 V	21”

4.3 AGC adjustment

Measure the voltage of RF AGC by connecting digital DC voltmeter with TP1, receive weak signal (40dBu) and the static AGC voltage of TP1 AGC should be $V1=4V\pm0.2V$; the receive medium signal (60dBu), adjust the value of PAGE8 RF. AGC of factory menu and the start-control voltage of TP1 AGC should be $V2=3.5V\pm0.2$.if $V2>3.5V$, then the voltage is -1 or -2, if $V2<3.5V$, then the voltage is+1 or+2. after adjustment the picture should not appear no-sync , distortion and moire.

White balance and screen-grid voltage VG2 adjustment

After enter PAGE3 of factory menu, use remote sensor directly to adjust white balance by pressing the following digital buttons:

“1”=R.BIAS(+) “2”=G.BIAS(+) “3”=B.BIAS(+)

“4”=R.BIAS(-) “5”=G.BIAS(-) “6”=B.BIAS(-)

press “pp” button to select picture mode→T1→T2→bright→soft→nature→user→ the current picture mode will be display on the screen.

The T1 mode has the maximum value of brightness and contrast with all the other items min. Value of all the analog are minimum while in T2 mode.

Before adjustment you should set the following items :SUB-BRIGHT=50, R.B=100, G.B=100, B.B=100, R.D=100, G.D=15, B.D=100

Adjustment method: 1. press PP button to select T2 picture mode, press CH+/- to select V.K, press vol+ to let the field scanning fail to oscillate, adjust the screen-grid potentiometer on FBT clockwise to let horizontal bright line just appear on the screen; let the value of G.B unchanged, adjust R-BIAS and B-BIAS to let the horizontal bright line appear white. If the green horizontal line don't appear firstly,

fine-tune the screen-grid voltage, then adjust R.B and B.B until red, green and blue just appear. After adjustment press VOL- to obtain normal field scanning mode.

4.4 Receive grey-scale signal (D8), enter PAGE4 of factory menu, press PP to select T2 picture mode, adjustment SUB-BRIGHT to let picture on the screen microbright.

4.5 receive white balance adjustment signal

enter PAGE3 of factory menu, press PP to select T1 picture mode, let the value of GD unchanged, adjust RD and B.D to let the white part of the picture appear "white".

4.6 Use white balancer to rectify the white balance under following conditions

colour temperature:12000K+8MPCD

$x = 0.270 \pm 0.008$ $Y = 0.283 \pm 0.008$ dark space : 4.5nit, bright space: 60nit

Note:1. Check the white balance of bright field and dark field by receiving monochrome signal or adjusting the degree of saturation to minimum under maintenance condition, adjust RGB BIAS in dark field and RGB DRIVE in bright area, adjust bright/dark balance repeatedly until the bright and dark field have no colour drift.

2. While the colour saturation changed from maximum to minimum, if the dark balance appears changeable, adjust RY.DC.LVL and BY.DC.LVL (page3) to let it coincide with white balance.

3. If the dark balance appears changeable while connected with DVD, adjust YUV.BY.DC and YUV.RY.DC (PAGE4) to let it coincide with white balance.

4.7 High voltage and filament voltage check

Connect a high-voltage meter between anode cap of picture tube and the ground, measure the filament voltage using rms voltmeter, set the picture mode to "standard", filament voltage is $6.3 \pm 1V_{rms}$, the high-voltage shown below:

CRT Model	High Voltage	Note
A34AGT13X15(F)	22±1K V	14"
A51AEZ90X09(F)	25±1KV	21"
A51AKL13X53(M)	27±1KV	21"

4.8 x-ray protection check

Receive local TV signal, set the picture mode to "standard", shorten the circuit and measure the value of TP1-TP2, restart the TV 30 seconds after turn off the power source and it should return to normal.

4.9 AV function check

according to the owner's manual require, connect to the AV equipment and the AV interface:

VIDEO IN:	1 Vp-p 75OHM	AUDIO IN:	(-8±3)dBm > 47 kOHM
S interface Y IN:	1 Vp-p 75OHM	C IN:	0.3 Vp-p 75OHM
DVD Y IN:	1 Vp-p 75OHM	Cr IN:	0.7 Vp-p 75OHM
		Cb IN:	0.7 Vp-p 75OHM

4.10 AV parts check

incept to standard the TV signal:

- AV and crossfire and allophone and shake ;
- The user control function and picture model
- The remote control function check;
- Color pure and converge check.

4.11 leave factory state setup

Picture model (PP)	STENDARD
language	All the country language
Color system	AUTO
C.CAPTION	C1
CCD ON MUTE	OFF
RECEPTION	AIR
AFT	ON
MTS	AUTO
PASSWORD	CLEAR
volume	30

4.12 the factory menu adjustment model pre-set

OSD	item	Pre-set	model
P1-60			
V SIZE	60HZ field amplitude	50	4.5.1
V SHIFT	60HZ field center	0	4.5.1
H-PHASE	60HZ H-center	9	4.5.1
V LINE	60HZ V-line	15	4.5.1
V SC	60HZ field S-correct	10	4.5.1
V COMP	field amplitude compensate	7	fixed
L.BLK	Left blanking	3	fixed
R.BLK	Right blanking	3	fixed
P3-50			
V SIZE	50HZ field amplitude	50	4.5.2
V SHIFT	50HZ field center	0	4.5.2
H-PHASE	50HZ H-center	6	4.5.2
V LINE	50HZ V-line	13	4.5.2
V SC	50HZ field S-correct	10	4.5.2
P5			
LINE	Level bright line	0	0=normal 1= Level bright line
RB	Red cut off	100	4.4
GB	Green cut off	100	4.4
BB	Blue cut off	100	4.4
RD	Red driver	100	4.4
GD	Green driver	15	4.4
BD	Blue driver	100	4.4
P6			
RF AGC	RF AGC	30	4.3
SUB-BRI	Sub-brightness	127	4.4
SUB-CNT	Sub-contrast	31	fixed
SUB-COL	Sub-colour	15	fixed
SUB-SHP	Sub-definition	15	fixed

OSD	item	Pre-set	model
SUB-TINT	Sub-tint	28	fixed
P7			
VOL.FIL	Volume control ADC filter	0	fixed
OSD.COT	OSD contrast	2	fixed
OSD.HPOS	OSD center	6	fixed
AFT	Line AFC loop gain and sync gate switch	1	fixed
VIF SW	IF3=45.75MHZ	3	fixed
SIF SW	Sound IF0=4.5MHZ	0	fixed
VIDEO LEVEL	VIDEO LEVEL	3	fixed
P8			
GY ANGLE	G-Y demodulation angle	0	fixed
V.R TM	Filed scan strting time	0	fixed
R/B ANG	R-Y/B-Y demodulation angle	8	Fixed
R/B BAL	R-Y/B-Ydemodulation balance	8	fixed
C TRAP	Color trap filter	6	fixed
H FREQ	H-frequency	16	fixed
C.BPF TEST	Color band filter center frequency	0	fixed
P9			
OVER.MOD.SW	Selection over-modulation function	0	Fixed,0=nothing 1=have
OVER.MOD.LVL	Adjustment over-modulation working point	0	fixed
BLK.STR	Dark level expand starting control point	0	Fixed,0=40IRE 2=60IRE 3-OFF
BLK.GAIN	Dark level expand gain	0	Fixed,0=MIN 2=MAX
Y.APF	Selection color trap filter	0	0=trap filter, 1= direct pass(YcbCr&Y/C)
PRE.ADJ	Pre-shoot	3	fixed, 0=narrow 3=width
OVER ADJ	overshoot	3	Fixed,a 0=narrow 3=width
C.VCO.ADJ	Color VCO frequency adjustment	4	fixed,0-4-7=-120KHZ-0-90KHZ
P10			
BRT.ABL.DEF	Brightness ABL	0	fixed,0=ABL ON 1=ABL OFF
MID.STP.DEF	ABL start control point	0	fixed
BRT.ABL.THR	ABL threshold	7	fixed
WPL.OPE	White peak limit	2	fixed
V BLK.SW	Field blanking switch	0	fixed ,0=nomarl;1=width model
FBP BLK SW	Horizontal blanking switch	1	fixed,0=inside produce;1=FBP and inside logic "and"
DC REST	DC recover rate	1	fixed,0=100% 1=107%
CD.MODE	Field frequency division model	0	fixed,0=auto

OSD	item	Pre-set	model
P11			
CORE GAIN	Noise reduction	2	fixed,0=OFF 1=MIN 3=MAX
γ.GAMA	r-correct	0	fixed,0=OFF
RGB TEMP.SW	RGB DC output temperature speciality	1	fixed
A.MONI SW	Selection pin5 output	1	Fixed, 1=SAO
SVO OR FSC	Selection pin5 output	0	fixed,0=VIDEO 1=FSC(color sub-carrier wave)
CROSS B/W	Selection test signal	0	fixed,0=TV
CRAY.MODE	Test signal	0	fixed,0=white(75%)1=grey(15%)
P12			
BY TV	Blue chromatism DC level	8	4.4 adjustment dark white balance(TV/AV model)
RY TV	Red chromatism DC level	8	4.4 adjustment dark white balance(TV/AV model)
BY YUV	DVD input Blue chromatism DC level	8	4.4 adjustment dark white balance (DVD input)
RY YUV	DVD input Red chromatism DC level	8	4.4 adjustment dark white balance(DVD input)
S.TRAP.TEST	Sound trap filter adjustment	6	fixed
LOW.BRI	Min-brightness	28	fixed
LOW.CONT	Min-contrast	30	fixed
P13			
COL.KILL	Achromatic level	5	fixed,0=-30dB 3=-40dB
VCO.FREQ	VCO frequency	32	fixed
P14			
Y GAIN		0	fixed
Y TH		0	fixed
B OFFSET		0	fixed
B WIDTH		0	fixed
C OFFSET		0	fixed
C WIDTH		0	fixed
CAN.V CHIP	V-CHIP	0/1	1=CAN.V-CHIP
OPTION			
AV	AV selection	3	AV input select(3=AV1/AV2/S/DVD)
MTS	MTS IC selection	1/0	0=nothing,1=72700 2=AN5832
V.OFF.MOTE	Turn off model	1	0=discharge,1=close
PWR.MEM	Turn on model	0/2	0=standby,1=auto turn on,2=memory
1115	select LV1115	0	fixed,0=nothing;1=have
BLCK GROND	No signal background selection	1	0=nothing 1/3=blue background;2=black background
N/PN	South America and North America selection	1/0	0=South America;1=North America

OSD	item	Pre-set	model
1115(the unit no use)			
VOL.OFFSET			
GAIN			
PWM LOGIC			
AVL MODE			
AVL DET LEVEL			
AVL SLOPE			
PWM SET			
VOL 1	1% volume control speciality	30	fixed
VOL 25	25%volume control speciality	32	fixed
VOL 50	50%volume control speciality	68	fixed
VOL 75	75%volume control speciality	82	fixed
72700			
ALC	ALC	1	fixed ,1=ALC ON
VOL	Baseband model ,input level adjustment	0	The unit no use
SAP LEVEL	SAP level	1	fixed
SIF.M/BB.M	SIF and baseband model	0	fixed,0=SIF MODE 1=BB MODE
5832			
AGC		1	fixed

Note: above “/” are the adjustment data for North America, below it are for South America.

IC BLOCK DIAGRAM

LA76931

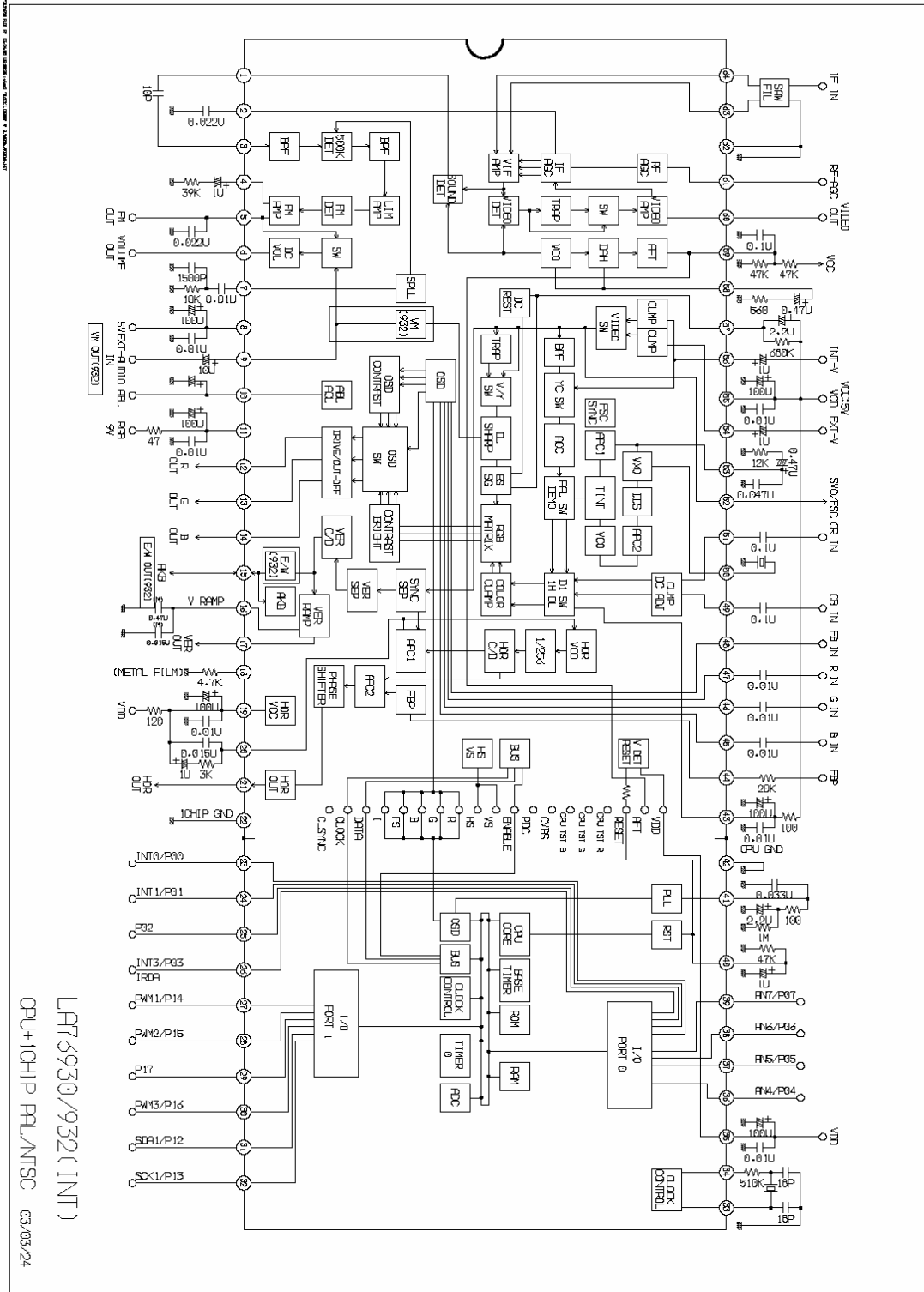

Function introduction to pin

pin	function	Reference voltage (V)	pin	function	Reference voltage (V)
1	SIF output	2.28	64	PIF input1	2.86
2	PIF AGC	2.61	63	PIF input 2	2.86
3	SIF input	3.11	62	IF GND	0
4	FM filter	2.64	61	RF AGC output	4.55
5	FM filter/sound output	2.25	60	Video output	2.30
6	Sound output	2.24	59	AFT filter	2.50
7	SIF APC filter	2.24	58	APC filter	2.60
8	IF VCC(5V)	4.92	57	Black level detection filter	2.50
9	Expanded sound input	2.25	56	Internal video input and S-C input	2.70
10	ABL	3.21	55	Video, colour and deflexion power VCC	4.90
11	RGB VCC(8V/18Ma)	8.00	54	Expanded video input and Y input	2.50
12	R ouput	2.65	53	Colour APC filter	3.40
13	G ouput	2.65	52	Selection video output and FSC output	2.40
14	B ouput	2.67	51	Cr input	2.50
15	AKB (undo)	2.31	50	4.43 MHZ crystal	2.73
16	Field sawtooth filter to capacitance	2.16	49	Cb input	2.50
17	Field output	2.34	48	Y(DVD) input	
18	VCO Reference voltage	1.65	47	DDS filter	1.89
19	H/BUS VCC(5V/27mA)	6.81	46	Y(Y/C) input	
20	H/APC filter	2.54	45	C(Y/C) input	
21	H-output	0.28	44	Retrace impulse input	1.20
22	Video, colour and deflexion ground	0	43	CCD VCC	4.50
23	x-ray protection, low level availability	5.00	42	CPU GND	0
24			41	PLL	3.50
25			40	reset	4.00
26	IR control input	4.90	39	Button input	0.32
27			38	TV/AV H=TV L=AV	0
28	POWER H=OFF L=ON	0	37	AV1/AV2	5.00
29	STAND-BY	5	36	MUTE high level	5.00

30	Mute, high Level availability	0	35	VDD	5.00
31	I2C DATA	5.00	34	x T2	4.50
32	I2C CLOCK	5.00	33	x T1	2.70

KA5Q0565RT

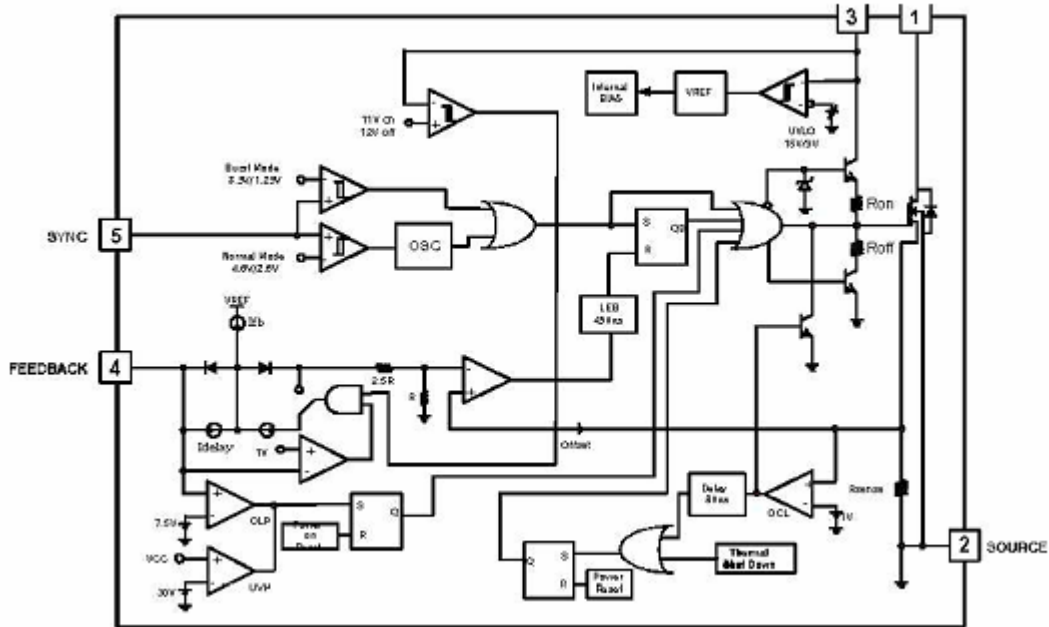

Function introduction to pin

pin	name	function	Reference Voltage(V)
1	Drain	drain output of MOSFET, current-limiting checking point of internal drain current.	283
2	GND	source of MOSFET, common ground and reference of circuit controlled by source.	0
3	Vcc	Control circuit power input, provide starting and stabilizing Operating current.	23
4	Vfb	Connect it with inverting input terminal of PWM comparator, the collector of optical coupler can be connected to it. To work stably, connect a capacitor between it and the ground. If the voltage upon it reaches to 7.5V, the overvoltage protection will work.	1.35
5	Sync	Connect it with sync detector for quasi-resonance conversion. Normal quasi-resonance work, threshold voltage upon sync comparator is 4.6V/2.6V. while expanding quasi-resonance operating mode, the threshold voltage will change to 3.0V/1.8V.	5.65

AN7522

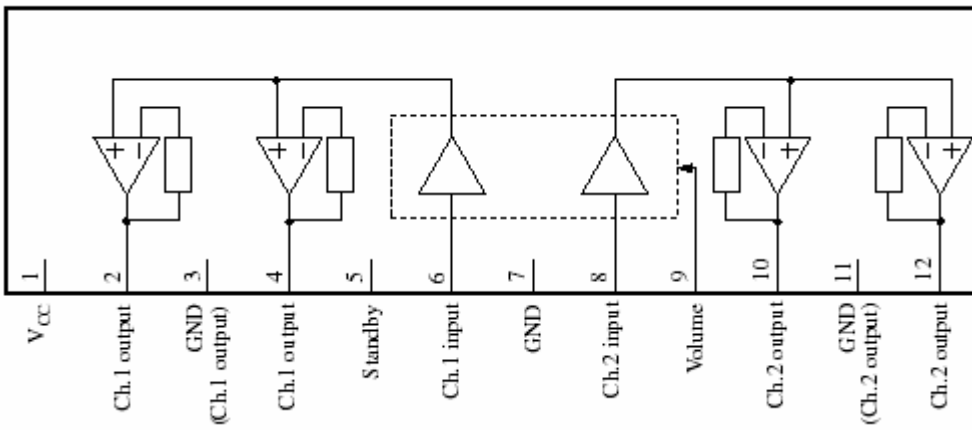

Pins function

pin	function	pin	function
1	power	7	GND input
2	CH1+ output	8	CH2 input
3	GND	9	volume
4	CH1- output	10	CH1+ output
5	Stand-by	11	GND (CH2 output)
6	CH1 input	12	CH1+ output

LA78040

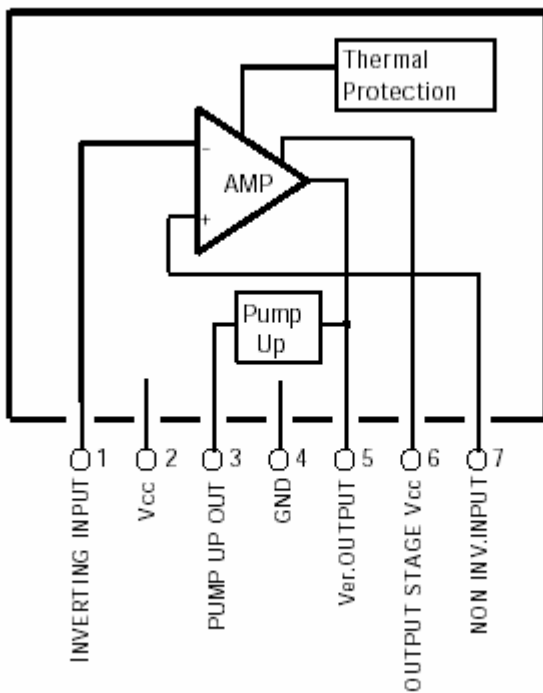

Pins function

pin	function	pin	function
1	Inverting input	5	Ver. output
2	VCC	6	Output stage vcc
3	Pump up output	7	NON inverting input
4	GND		

LA72700

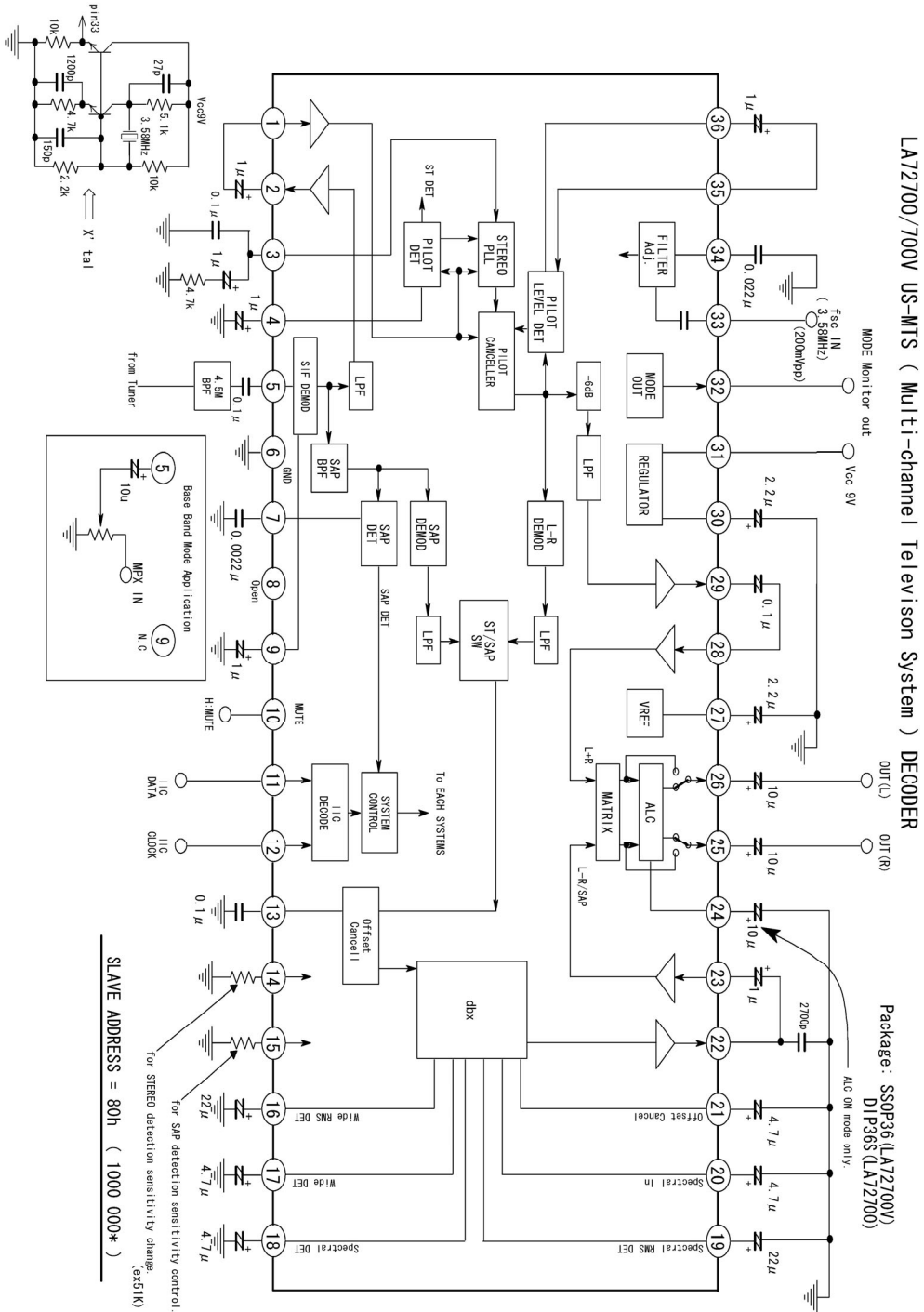

Pin description of LA72700:

pin	function	pin	function
1	AC coupling input	19	dbx RMS detection
2	AC coupling output	20	Dbx main signal V/I charge filter
3	Stereo VCO PLL filter	21	Decoupling filter
4	Pilot level check	22	AC coupling output
5	Signal input	23	AC coupling input
6	GND	24	ALC filter
7	SAP carrier level check	25	R output
8		26	L output
9	SIF decoupling filter	27	Reference voltage(DC3.8V)
10	mute(5V)	28	AC coupling input
11	Serial data input(SDA)	29	AC coupling output
12	Serial clock input (SCL)	30	Voltage regulation filter
13	Decoupling filter	31	VCC(9V)
14	Stereo detection sensitivity	32	Model output: MONO=0.9V SAP=2.0V STEREO=3.0V STEREO+SAP=3.8V
15	SAP detection sensitivity	33	Sub-carrier input(3.579545MHZ 200Mv)
16	dbx RMS detection	34	Filter adjustment check
17	Dbx broad band detection	35	Pilot dispel reference signal1
18	Dbx spectrum detection	36	Pilot dispel reference signal2

WIRING DIAGRAM

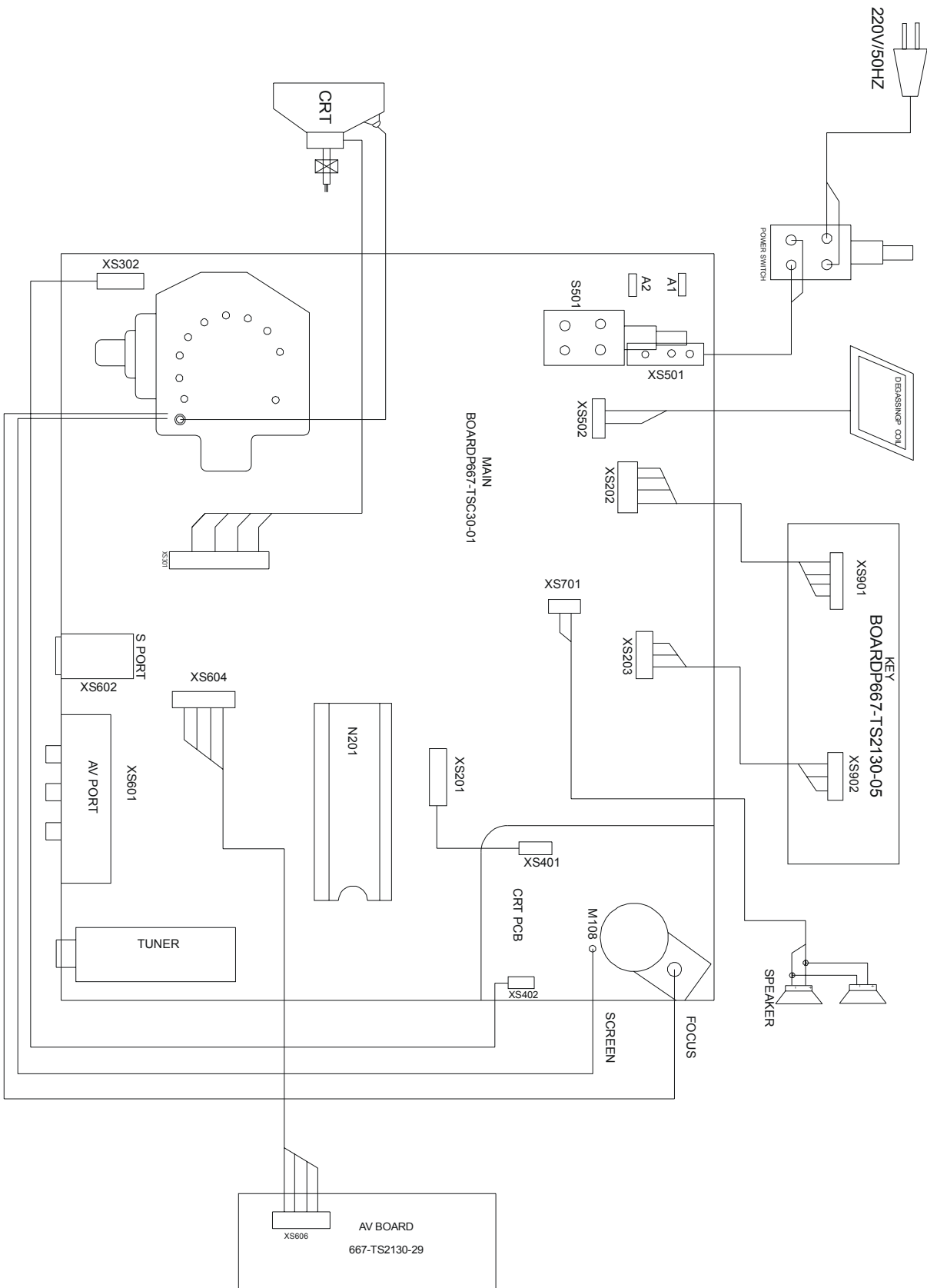

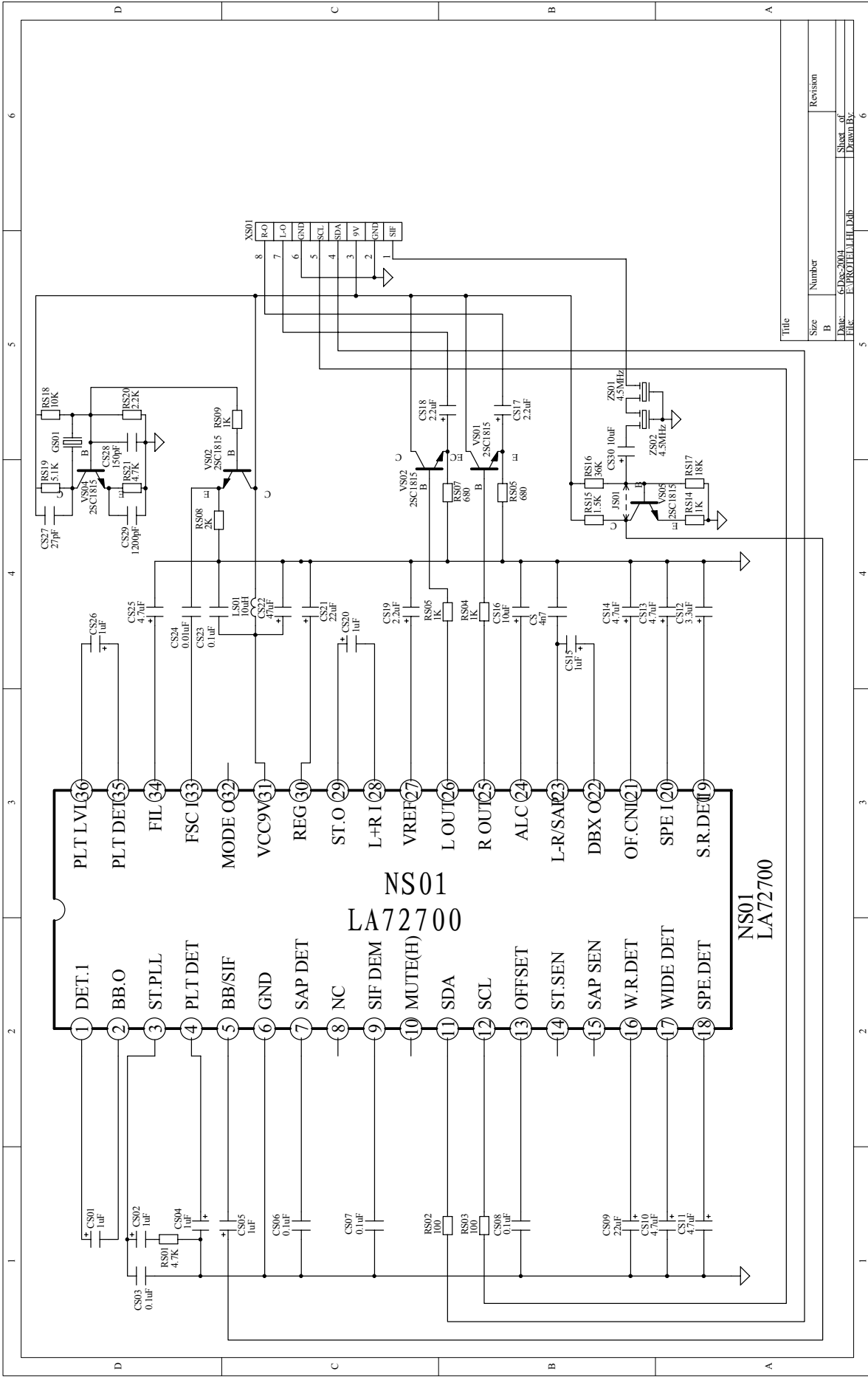

Title	Size	Number	Revision
B	B	6038-2001	
Date:	E:\PROJ\LA72700		Sheet of 6
File:			Drawn By:

1 2 3 4 5 6

A B C D

