



North/Latin America
Europe/Africa
Asia/Oceania

Internal Use Only

<http://aic.lgservice.com>
<http://eic.lgservice.com>
<http://biz.lgservice.com>

LCD TV

SERVICE MANUAL

CHASSIS : LP91H

MODEL : 26LD330 26LD330-MA

CAUTION

BEFORE SERVICING THE CHASSIS,
READ THE SAFETY PRECAUTIONS IN THIS MANUAL.

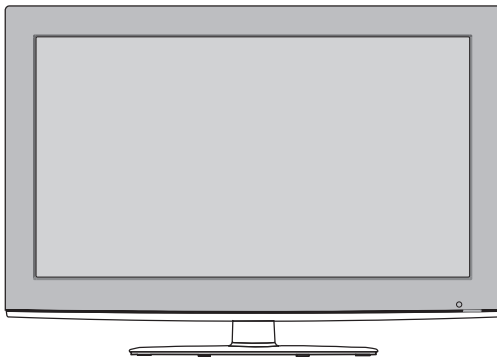

P/NO : MFL63285205 (1003-REV00)

Printed in Korea

CONTENTS

CONTENTS	2
SPECIFICATION	3
ADJUSTMENT INSTRUCTION	7
TROUBLE SHOOTING	14
BLOCK DIAGRAM.....	17
EXPLODED VIEW	18
SVC. SHEET	

SAFETY PRECAUTIONS

IMPORTANT SAFETY NOTICE

Many electrical and mechanical parts in this chassis have special safety-related characteristics. These parts are identified by \triangle in the Schematic Diagram and Exploded View.

It is essential that these special safety parts should be replaced with the same components as recommended in this manual to prevent Shock, Fire, or other Hazards.

Do not modify the original design without permission of manufacturer.

General Guidance

An **isolation Transformer should always be used** during the servicing of a receiver whose chassis is not isolated from the AC power line. Use a transformer of adequate power rating as this protects the technician from accidents resulting in personal injury from electrical shocks.

It will also protect the receiver and its components from being damaged by accidental shorts of the circuitry that may be inadvertently introduced during the service operation.

If any fuse (or Fusible Resistor) in this TV receiver is blown, replace it with the specified.

When replacing a high wattage resistor (Oxide Metal Film Resistor, over 1 W), keep the resistor 10mm away from PCB.

Keep wires away from high voltage or high temperature parts.

Before returning the receiver to the customer,

always perform an **AC leakage current check** on the exposed metallic parts of the cabinet, such as antennas, terminals, etc., to be sure the set is safe to operate without damage of electrical shock.

Leakage Current Cold Check(Antenna Cold Check)

With the instrument AC plug removed from AC source, connect an electrical jumper across the two AC plug prongs. Place the AC switch in the on position, connect one lead of ohm-meter to the AC plug prongs tied together and touch other ohm-meter lead in turn to each exposed metallic parts such as antenna terminals, phone jacks, etc.

If the exposed metallic part has a return path to the chassis, the measured resistance should be between 1 M Ω and 5.2 M Ω .

When the exposed metal has no return path to the chassis the reading must be infinite.

An other abnormality exists that must be corrected before the receiver is returned to the customer.

Leakage Current Hot Check (See below Figure)

Plug the AC cord directly into the AC outlet.

Do not use a line Isolation Transformer during this check.

Connect 1.5 K / 10 watt resistor in parallel with a 0.15 μ F capacitor between a known good earth ground (Water Pipe, Conduit, etc.) and the exposed metallic parts.

Measure the AC voltage across the resistor using AC voltmeter with 1000 ohms/volt or more sensitivity.

Reverse plug the AC cord into the AC outlet and repeat AC voltage measurements for each exposed metallic part. Any voltage measured must not exceed 0.75 volt RMS which corresponds to 0.5 mA.

In case any measurement is out of the limits specified, there is possibility of shock hazard and the set must be checked and repaired before it is returned to the customer.

Leakage Current Hot Check circuit

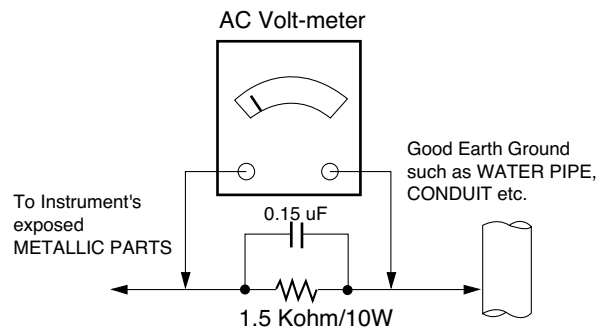

When 25A is impressed between Earth and 2nd Ground for 1 second, Resistance must be less than 0.1 Ω

*Base on Adjustment standard

SPECIFICATION

NOTE : Specifications and others are subject to change without notice for improvement.

1. Application range

This spec sheet is applied to LCD TV used LP91H chassis.

2. Specification

Each part is tested as below without special appointment.

- 1) Temperature: 25 °C ± 5 °C(77 °F ± 9 °F), CST: 40 °C ± 5 °C
- 2) Relative Humidity : 65 % ± 10 %
- 3) Power Voltage
 - : Standard input voltage(AC 100-240 V~ 50/60 Hz)
 - * Standard Voltage of each products is marked by models.
- 4) Specification and performance of each parts are followed each drawing and specification by part number in accordance with BOM.
- 5) The receiver must be operated for about 5 minutes prior to the adjustment.

3. Test method

- 1) Performance: LGE TV test method followed
- 2) Demanded other specification
 - Safety: CE, IEC specification
 - EMC : CE, IEC

4. Electrical specification

No.	Item	Specification	Measurement	Remark
1	Screen Size	66 cm(26 inch) wide Color Display Module		Resolution : 1366*768
2	Aspect Ratio	16:9		
3	LCD Module	66 cm(26 inch) TFT WXGA LCD		
4	Operating Environment	Temp. : 0 deg ~ 40 deg		
		Humidity : 0 % ~ 85 %		
5	Storage Environment	Temp. : -20 deg ~ 60 deg		
		Humidity : 0 % ~ 85 %		
6	Input Voltage	AC 100-240 V~, 50/60 Hz		
		78.36 W HD		
7	LCD Module	AUO	626 x 373 x 45	Outline Dimension
			0.46125 x 0.46125	Pixel Pitch
			4 CCFLs	Backlight assembly
		SHARP	626 x 373 x 45	Outline Dimension
			0.4215 x 0.1405	Pixel Pitch
8 CCFT	Backlight assembly			

5. Chroma& Brightness (Optical)

(1) LCD Module

- The Color Coordinates check condition
 - 50 cm from the surface, Full White Pattern
 - Picture mode Vivid

No.	Item		Min.	Typ.	Max.	Unit	Remark
1.	Luminance (W/O PC mode)		360	450		cd/m ²	AUO/ SHARP
2.	View angle (R/L, U/D)			158 / 158		degree	
3.	Color Coordinates	White	X	Typ -0.03	0.278	Typ +0.03	Sharp
			Y		0.285		
		RED	X		0.642		
			Y		0.341		
		Green	X		0.285		
			Y		0.603		
		Blue	X		0.146		
			Y		0.066		
		White	X	Typ -0.03	0.280	Typ +0.03	AUO
			Y		0.290		
		RED	X		0.640		
			Y		0.330		
		Green	X		0.281		
			Y		0.590		
		Blue	X		0.150		
			Y		0.050		
4.	Module Contrast ratio		2,400	3,000			AUO
			2,000	2,500			IPS
5.	Luminance Variation				1.3		

6. Component Video Input (Y, Pb, Pr)

No.	Specification				Remarks
	Resolution	H-freq(kHz)	V-freq(Hz)	Pixel Clock(MHz)	
1	720* 480	15.73	59.94	13.500	SDTV, DVD 480I(525I)
2	720* 480	15.75	60.00	13.514	SDTV, DVD 480I(525I)
3	720* 576	15.625	50.00	13.500	SDTV, DVD 576I(625I) 50 Hz
4	720* 480	31.47	59.94	27.000	SDTV 480P
5	720* 480	31.50	60.00	27.027	SDTV 480P
6	720* 576	31.25	50.00	27.000	SDTV 576P 50 Hz
7	1280* 720	44.96	59.94	74.176	HDTV 720P
8	1280* 720	45.00	60.00	74.250	HDTV 720P
9	1280* 720	37.50	50.00	74.25	HDTV 720P 50 Hz
10	1920* 1080	28.125	50.00	74.250	HDTV 1080I 50 Hz
11	1920* 1080	33.72	59.94	74.176	HDTV 1080I
12	1920* 1080	33.75	60.00	74.25	HDTV 1080I
13	1920* 1080	56.25	50	148.5	HDTV 1080P
14	1920* 1080	67.432	59.94	148.350	HDTV 1080P
15	1920* 1080	67.5	60.00	148.5	HDTV 1080P

7. RGB

(Analog PC, RGB-DTV - NOT SUPPORT)

No.	Specification				Proposed	Remarks
	Resolution	H-freq(kHz)	V-freq(Hz)	Pixel Clock(MHz)		
1	640* 350	31.468	70.09	25.17	EGA	
2	720* 400	31.469	70.09	28.32	DOS	
3	640* 480	31.469	59.94	25.17	VESA(VGA)	
4	800* 600	37.879	60.317	40	VESA(SVGA)	
5	1024* 768	48.363	60.004	65	VESA(XGA)	
6	1280* 768	47.776	59.87	79.5	VESA(WXGA)	
7	1360* 768	47.72	59.799	84.75	VESA(WXGA)	
8	1280* 1024	63.668	59.895	109.00	XGA	Only FHD Model
9	1920* 1080	66.587	59.934	138.50	WUXGA(Reduced Blanking)	Only FHD Model

8. HDMI Input(PC)

(PC-Spec. out but it can be shown the picture at only HDMI/ DVI IN 1 via DVI to HDMI Cable)

No.	Resolution	H-freq(kHz)	V-freq.(Hz)	Pixel clock(MHz)	Proposed	Remarks
1	640 x 480	31.469	59.94	25.17	VESA(VGA)	
2	800 x 600	37.879	60.317	40.00	VESA(SVGA)	
3	1024 x 768	48.363	60.004	65.00	VESA(XGA)	
4	1280 x 768	47.776	59.87	79.5	VESA(WXGA)	
5	1360 x 768	47.72	59.799	84.62	VESA(WXGA)	
6	1366 x 768	47.7	60.00	84.62	WXGA	
7	1280 x 1024	63.595	60.00	108.875	SXGA	
8	1920 x 1080	66.647	59.988	138.625	WUXGA	

9. HDMI Input(DTV)

No.	Specification				Proposed	Remarks
	Resolution	H-freq(kHz)	V-freq(Hz)	Pixel Clock(MHz)		
1	720 x 480	15.73	59.94	13.500	SDTV, DVD 480I(525I)	Spec. out but display.
2	720 x 480	15.75	60.00	13.514	SDTV, DVD 480I(525I)	
3	720 x 576	15.625	50.00	13.500	SDTV, DVD 576I(625I) 50 Hz	
4	720 x 480	31.47	59.94	27	SDTV 480P	
5	720 x 480	31.5	60.00	27.027	SDTV 480P	
6	720 x 576	31.25	50.00	27	SDTV 576P	
7	1280 x 720	44.96	59.94	74.176	HDTV 720P	
8	1280 x 720	45	60.00	74.25	HDTV 720P	
9	1280 x 720	37.5	50.00	74.25	HDTV 720P	
10	1920 x 1080	28.125	50.00	74.25	HDTV 1080I	
11	1920 x 1080	33.72	59.94	74.176	HDTV 1080I	
12	1920 x 1080	33.75	60.00	74.25	HDTV 1080I	
13	1920 x 1080	56.25	50.00	148.5	HDTV 1080P	
14	1920 x 1080	67.432	59.94	148.350	HDTV 1080P	
15	1920 x 1080	67.5	60.00	148.5	HDTV 1080P	
16	1920 x 1080	27	24.00	74.25	HDTV 1080P	
17	1920 x 1080	33.75	30.00	74.25	HDTV 1080P	

ADJUSTMENT INSTRUCTION

1. Application Range

This specification sheet is applied to all of the LCD TV, LP91H chassis.

2. Specification

- (1) Because this is not a hot chassis, it is not necessary to use an isolation transformer. However, the use of isolation transformer will help protect test instrument.
- (2) Adjustment must be done in the correct order.
- (3) The adjustment must be performed in the circumstance of $25\text{ }^{\circ}\text{C} \pm 5\text{ }^{\circ}\text{C}$ of temperature and $65\% \pm 10\%$ of relative humidity if there is no specific designation.
- (4) The input voltage of the receiver must keep AC 100-220 V, 50/60 Hz.
- (5) Before adjustment, execute Heat-Run for 5 minutes at RF no signal.

3. Adjustment items

3.1. PCB assembly adjustment items

- (1) Download the MSTAR main software (IC800, Mstar ISP Utility)
 - 1) Using D/L Jig
 - 2) Using USB Memory Stick.
- (2) Input Tool-Option.
- (3) Download the EDID
 - EDID datas are automatically downloaded when adjusting the Tool Option2
- (4) ADC Calibration - RGB / Component
- (4) Check SW Version.

3.2. SET assembly adjustment items

- (1) Input Area option
- (2) Adjustment of White Balance : Auto & Manual
- (3) Input Tool-Option/Area option
- (4) Intelligent Sensor Inspection Guide
- (5) Preset CH information
- (6) Factoring Option Data input

4. PCB assembly adjustment method

4.1. Mstar Main S/W program download

4.1.1. Using D/L Jig

- (1) Preliminary steps
 - 1) Connect the download jig to D-sub(RGB) jack.

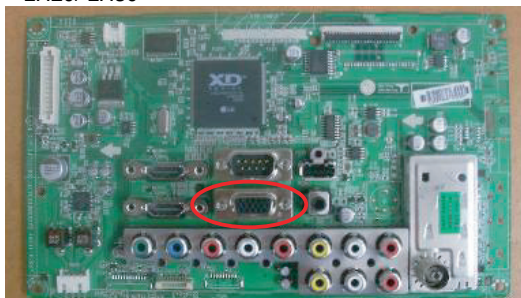

- (2) Download steps
 - 1) Execute 'ISP Tool' program, the main window(Mstar ISP utility Vx.x.x) will be opened.
 - 2) Click the "Connect" button and confirm "Dialog Box"

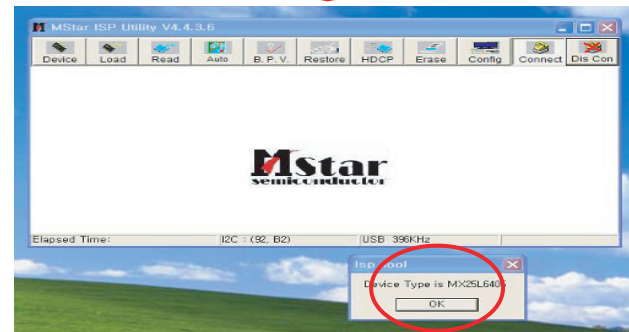
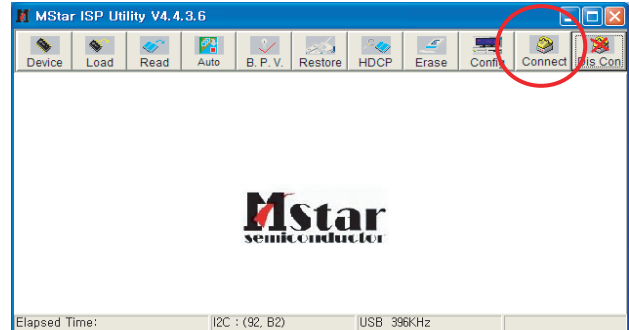

- 3) Click the "Config." button and Change speed I2C Speed setting : 350 KHz ~ 400 KHz

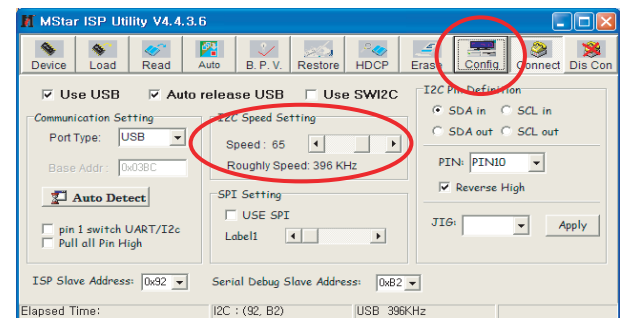

- 4) Read and write bin file. Click "(1)Read" tab, and then load download file (XXXX.bin) by clicking "Read".

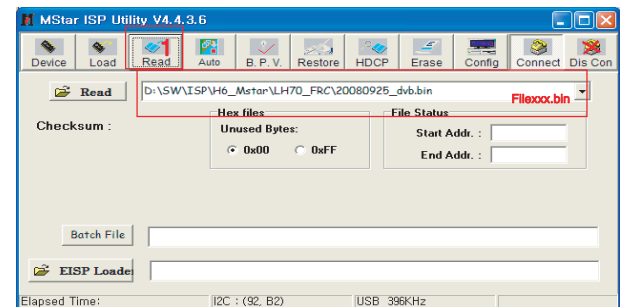

- 5) Click "(2) Auto" tab and set as below.
- 6) Click "(3) Run".
- 7) After downloading, you can see the "(4) Pass" message.

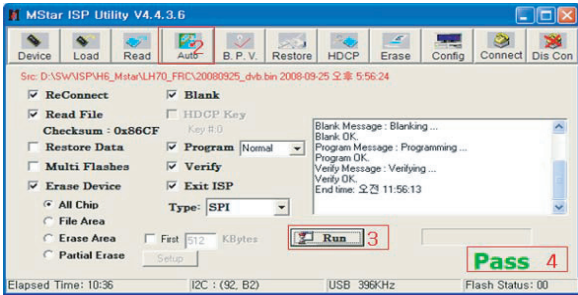

4.1.2. Using the Memory Stick

- * USB download : Service Mode

 - 1) Insert the USB memory stick to the ISB port.
 - 2) Automatically detect the SW Version.
-> S/W download process is executed automatically.
 - 3) Show the message "Copy the file from the Memory".

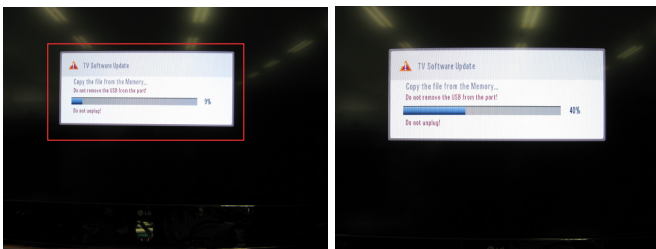

- 4) After Finished the Download, Automatically DC Off -> On

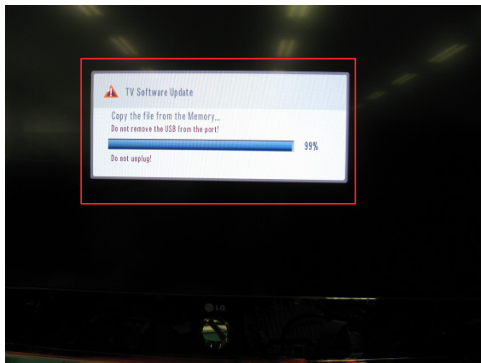

- 5) Check The update SW Version.

4.2. Input tool option.

- Adjust tool option refer to the BOM.
- Tool Option Input : PCBA Check Process
- Area Option Input : Set Assembly Process

After Input Tool Option and AC off
 Before PCBA check, you have to change the Tool option and have to AC off/on (Plug out and in)
 (If missing this process, set can operate abnormally)

- (1) Profile : Must be changed the option value because being different with some setting value depend on module maker, inch and market
- (2) Equipment : adjustment remote control.

- (3). Adjustment method
 - The input methods are same as other chassis.(Use IN-START Key on the Adjust Remocon.)
 (If not changed the option, the input menu can differ the model spec.)

Refer to Job Expression of each main chassis assembly (EBTxxxxxxx) for Option value
 Caution : Don't Press "IN-STOP" key after completing the function inspection.

4.3. EDID D/L method

Recommend that don't connect HDMI and RGB(D-SUB) cable when downloading the EDID.
 If not possible, recommend that connect the MSPG equipment.
 There are two methods of downloading the edid data

4.3.1. 1st Method

EDID datas are automatically downloaded when adjusting the Tool Option2.
 Automatically downloaded when pushing the enter key after adjusting the tool option2.
 It takes about 2seconds.

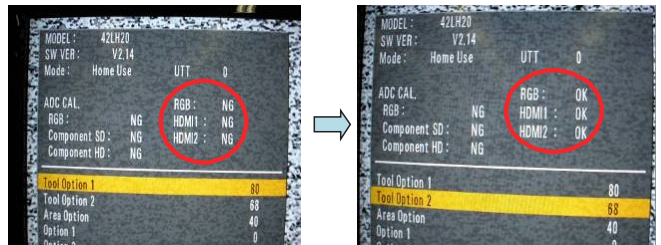

4.3.2. 2nd Method

- * Caution :
 Must be checked that the tool option is right or not.
 If tool option is wrong, hdmi edid data could not be downloaded well.

 - 1) Press the ADJ key
 - 2) Move to the EDID D/L and Press the right direction key(▶).
 - 3) Press the right direction key(▶) at Start.
 - 4) After about a few seconds, appear "OK", then complete.

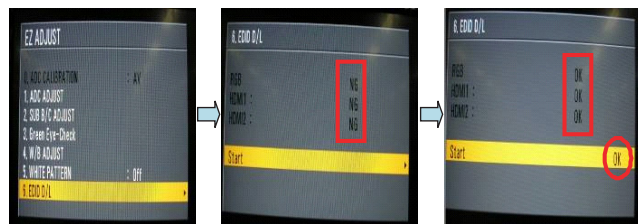

4.3.3. RS-232C command Method

- (1) Command : AE 00 10

- * Caution
 Don't connect HDMI and RGB(D-SUB) cable when downloading the EDID.
 If the cables are connected, Downloading of edid could be failed.

4.3.4. EDID data

(1) Analog(RGB): 128bytes>

	0	1	2	3	4	5	6	7	8	9	A	B	C	D	E	F
0	00	FF	FF	FF	FF	FF	FF	00	1E	6D	01	00	01	01	01	01
10	01	14	01	03	08	46	27	78	0A	D9	B0	A3	57	49	9C	25
20	11	49	4B	A1	08	00	45	40	01	01	61	40	01	01	01	01
30	01	01	01	01	01	01	1B	21	50	A0	51	00	1E	30	48	88
40	35	00	BC	88	21	00	00	1C	0E	1F	00	80	51	00	1E	30
50	40	80	37	00	BC	88	21	00	00	18	00	00	00	FC	00	4C
60	47	20	54	56	0A	20	20	20	20	20	20	20	20	00	00	FD
70	00	3A	3F	1C	44	0F	00	0A	20	20	20	20	20	20	00	56

(2) HDMI 1 : 256Bytes

	0	1	2	3	4	5	6	7	8	9	A	B	C	D	E	F
0	00	FF	FF	FF	FF	FF	FF	00	1E	6D	01	00	01	01	01	01
10	01	14	01	03	08	46	27	78	0A	D9	B0	A3	57	49	9C	25
20	11	49	4B	21	08	00	45	40	01	01	61	40	01	01	01	01
30	01	01	01	01	01	01	01	1D	00	72	51	D0	1E	20	6E	28
40	55	00	C4	8E	21	00	00	1E	1B	21	50	A0	51	00	1E	30
50	48	88	35	00	BC	77	21	00	00	1C	00	00	00	FC	00	4C
60	47	20	54	56	0A	20	20	20	20	20	20	20	20	00	00	FD
70	00	3A	3F	1C	44	0F	00	0A	20	20	20	20	20	20	01	C3
80	02	03	25	F1	4F	84	07	01	16	02	03	11	12	13	14	05
90	20	22	1F	10	23	09	07	07	83	01	00	00	68	03	0C	00
A0	10	00	80	1E	00	01	1D	00	80	51	D0	1C	20	40	80	35
B0	00	BC	88	21	00	00	1E	8C	0A	D0	8A	20	E0	2D	10	10
C0	3E	96	00	13	8E	21	00	00	18	8C	0A	A0	14	51	F0	16
D0	00	26	7C	43	00	C4	8E	21	00	00	98	01	1D	80	18	71
E0	1C	16	20	58	2C	25	00	C4	8E	21	00	00	9E	00	00	00
F0	00	00	00	00	00	00	00	00	00	00	00	00	00	00	00	2A

(3) HDMI 2 : 256Bytes

	0	1	2	3	4	5	6	7	8	9	A	B	C	D	E	F
0	00	FF	FF	FF	FF	FF	FF	00	1E	6D	01	00	01	01	01	01
10	01	14	01	03	08	46	27	78	0A	D9	B0	A3	57	49	9C	25
20	11	49	4B	21	08	00	45	40	01	01	61	40	01	01	01	01
30	01	01	01	01	01	01	01	1D	00	72	51	D0	1E	20	6E	28
40	55	00	C4	8E	21	00	00	1E	1B	21	50	A0	51	00	1E	30
50	48	88	35	00	BC	77	21	00	00	1C	00	00	00	FC	00	4C
60	47	20	54	56	0A	20	20	20	20	20	20	20	20	00	00	FD
70	00	3A	3F	1C	44	0F	00	0A	20	20	20	20	20	20	01	C3
80	02	03	25	F1	4F	84	07	01	16	02	03	11	12	13	14	05
90	20	22	1F	10	23	09	07	07	83	01	00	00	68	03	0C	00
A0	20	00	80	1E	00	01	1D	00	80	51	D0	1C	20	40	80	35
B0	00	BC	88	21	00	00	1E	8C	0A	D0	8A	20	E0	2D	10	10
C0	3E	96	00	13	8E	21	00	00	18	8C	0A	A0	14	51	F0	16
D0	00	26	7C	43	00	C4	8E	21	00	00	98	01	1D	80	18	71
E0	1C	16	20	58	2C	25	00	C4	8E	21	00	00	9E	00	00	00
F0	00	00	00	00	00	00	00	00	00	00	00	00	00	00	00	1A

4.4. ADC Calibration

4.4.1. ADC Calibration - Component (Using External pattern)

- (1) Required Equipments
 - Remote controller for adjustment
 - MSPG-925F/MSPG-1025/MSPG-3233 Pattern Generator
- (2) Process
 - 1) Change the Input to Component1 or 2 mode.
 - 2) Input the Component 480i@60 Hz 100% Color Bar YPbPr signal into Component1 or 2. (MSPG-925F Model: 209 / Pattern: 65)



- 3) Press ADJ key on R/C for adjustment.
- 4) Enter Password number. Password is "0 0 0 0".
- 5) Select "0. ADC calibration : Component" by using ▲/▼ (CH +/-) and press ENTER(■).
- 6) ADC adjustment is executed automatically .
- 7) When ADC adjustment is finished, this OSD appear



4.4.2. ADC Calibration-RGB

4.4.2.1. Method of Using External pattern

- (1) Required Equipments
 - Remote controller for adjustment
 - MSPG-925F/MSPG-1025/MSPG-3233 Pattern Generator
- (2) Process
 - 1) Change the Input to RGB mode.
 - 2) Input the PC 1024x768@60 Hz Horizontal Color Bar signal into RGB. (MSPG-925F Model: 60 / Pattern: 65)



- 3) Press ADJ key on R/C for adjustment.
- 4) Enter Password number. Password is "0 0 0 0".
- 5) Select "0. ADC calibration : RGB" by using ▲/▼(CH +/-) and press ENTER(■).
- 6) ADC adjustment is executed automatically .
- 7) When ADC adjustment is finished, this OSD appear



4.4.2.2. Method of Using Internal pattern

- (1) Apply model
19/22/26/32LD330
- (2) Process
 - 1) Change the Input to RGB mode.
 - 2) Press ADJ key on R/C for adjustment.
 - 3) Enter Password number. Password is "0 0 0 0".
 - 4) Select "0. ADC calibration : RGB" by using ▲/▼(CH +/-) and press ENTER(■).
 - 5) ADC adjustment is executed automatically .
 - 7) When ADC adjustment is finished, this OSD appear

Caution : No need to connect external input cable

Caution : Adjustment result is applied after SET Off/On

4.5. Check SW Version

- (1) Method
 - 1) Push In-start key on Adjust remote-controller.
 - 2) SW Version check
Check "SW VER : V3.xx"

LP91A	LPL L42FHD
S/W Ver 3.XX	
UTT 97	00 HDCP 0
SHOP Mode : auto home	
ADC CAL.	
RGB :	OK
Component SD :	OK
Component SD :	OK
Tool Option1	39848
Tool Option2	51
Area Option	1
OPTION1	43
OPTION2	46
OPTION3	0
OPTION4	0
System Control	
Audio Prescale	
Threshold	
Power Off History	
Panel Control	
Davinci / Auto Test	

5. PCB assembly adjustment method

5.1. Input Area-Option

- (1) Profile : Must be changed the Area option value because being different of each Country's Language and signal Condition.
- (2) Equipment : adjustment remote control
- (3) Adjustment method
 - The input methods are same as other chassis.(Use IN-START key on the Adjust Remocon.)

Refer to Job Expression of each main chassis assembly (EBTxxxxxxx) for Option value.

5.2. White Balance Adjustment

- Purpose : Adjust the color temperature to reduce the deviation of the module color temperature.
- Principle : To adjust the white balance without the saturation, Fix the one of R/G/B gain to 192 (default data) and decrease the others.
- Adjustment mode : Three modes - Cool / Medium / Warm
- Required Equipment
 - 1) Remote controller for adjustment
 - 2) Color Analyzer : CA100+ or CA-210 or same product (should be used in the calibrated ch by CS-1000)
LCD TV : CH9
 - 3) Auto W/B adjustment instrument(only for Auto adjustment)

5.2.1. Adjustment of White Balance

(For automatic adjustment)

- Connecting diagram of equipment for measuring

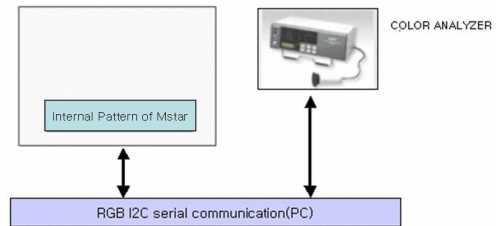

* LP91H Support RS-232C & I2C DDC Communication-White Balance Mode.

- (1) Enter the adjustment mode of DDC
 - Set command delay time : 50 ms
 - Enter the DDC adjustment mode at the same time heat-run mode when pushing the power on by power only key
 - Maintain the DDC adjustment mode with same condition of Heat-run => Maintain after AC off/on in status of Heat-run pattern display)

- (2) Release the DDC adjustment mode
 - Release the adjust mode after AC off/on or std-by off/on in status of finishing the Hear-run mode
 - Release the Adjust mode when receiving the aging off command(F3 00 00) from adjustment equipment.
 - Need to transmit the aging off command to TV set after finishing the adjustment.
 - Check DDC adjust mode release by exit key and release DDC adjust mode)

- (3) Enter the adjust mode of white balance)
 - Enter the white balance adjustment mode with aging command (F3, 00, FF)

* Luminance min value is 150 cd in the Cool/Medium/Warm mode(For LCD)

5.2.2. Adjustment of White Balance

(for Manual adjustment)

- (1) Color analyzer(CA100+, CA210) should be used in the calibrated ch by CS-1000
- (2) Operate the zero-calibration of the CA100+ or CA-210, then stick sensor to the module when adjusting.
- (3) For manual adjustment, it is also possible by the following sequence.
 - 1) Select white pattern of heat-run by pressing "POWER ON" key on remote control for adjustment then operate heat run longer than 15 minutes. (If not executed this step, the condition for W/B may be different.)
 - 2) Push "Exit" key.
 - 3) Change to the AV mode by remote control.
 - 4) Input external pattern (85% white pattern)
 - 5) Push the ADJ key -> Enter "0000" (Password)
 - 6) Select "3. W/B ADJUST"
 - 7) Enter the W/B ADJUST Mode
 - 8) Stick the sensor to the center of the screen and select each items (Red/Green/Blue Gain and Offset) using ▲/▼(CH +/-) key on R/C.
 - 9) Adjust R/ G/ B Gain using ◀▶(VOL +/-) key on R/C.
 - 10) Adjust three modes all (Cool/ Medium/ Warm) : Fix the one of R/G/B gain and change the others.
 - 11) When adjustment is completed, Enter "COPY ALL".
 - 12) Exit adjustment mode using EXIT key on R/C.

* CASE

First adjust the coordinate far away from the target value(x, y).

- 1) $x, y > \text{target}$
 - i) Decrease the R, G.
- 2) $x, y < \text{target}$
 - i) First decrease the B gain,
 - ii) Decrease the one of the others.
- 3) $x > \text{target}, y < \text{target}$
 - i) First decrease B, so make y a little more than the target.
 - ii) Adjust x value by decreasing the R
- 4) $x < \text{target}, y > \text{target}$
 - i) First decrease B, so make x a little more than the target.
 - ii) Adjust x value by decreasing the G

(4) Standard color coordinate and temperature when using the CA100+ or CA210 equipment

Mode	Color Coordinate		Temp.	Δuv
	x	y		
Cool	0.269 ± 0.002	0.273 ± 0.002	13,000 K	0.000
Medium	0.285 ± 0.002	0.293 ± 0.002	9,300 K	0.000
Warm	0.313 ± 0.002	0.329 ± 0.002	6,500 K	0.003

To check the Coordinates of White Balance, you have to measure at the below conditions.

Picture Mode : select Vivid and change

Dynamic Contrast : Off

Dynamic Colour : Off

-> Picture Mode change : Vivid -> Vivid(User)

(If you miss the upper condition, the coordinates of W/B can be lower than the spec.)

5.3. Checking the function of Local Dimming

(using adjusts Remote control)

- Dimming checking is doing in "Power Only" mode.
- Enter the signal of component. (Pattern : 7(combination), Time : 225 (1920 *1080))
- Push the button "Tilt".
- Checking the function of Dimming refer to the picture at below.
- Push the button "Tilt" or "Exit" key.

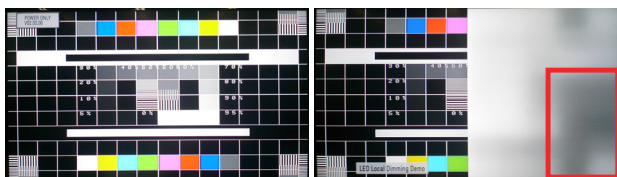

Pattern 7 (Combination)

Local Dimming Demo screen

TROUBLESHOOTING

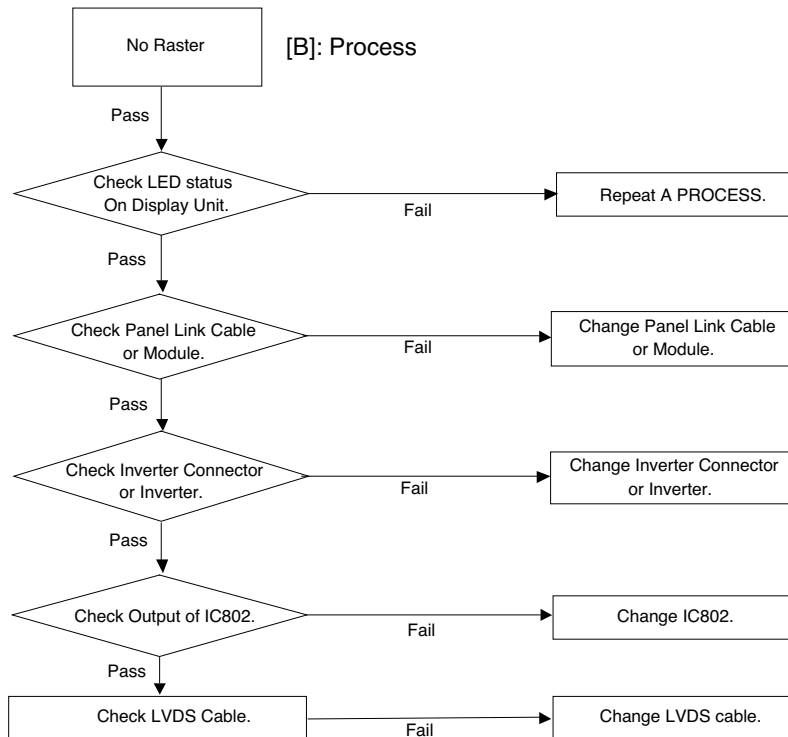
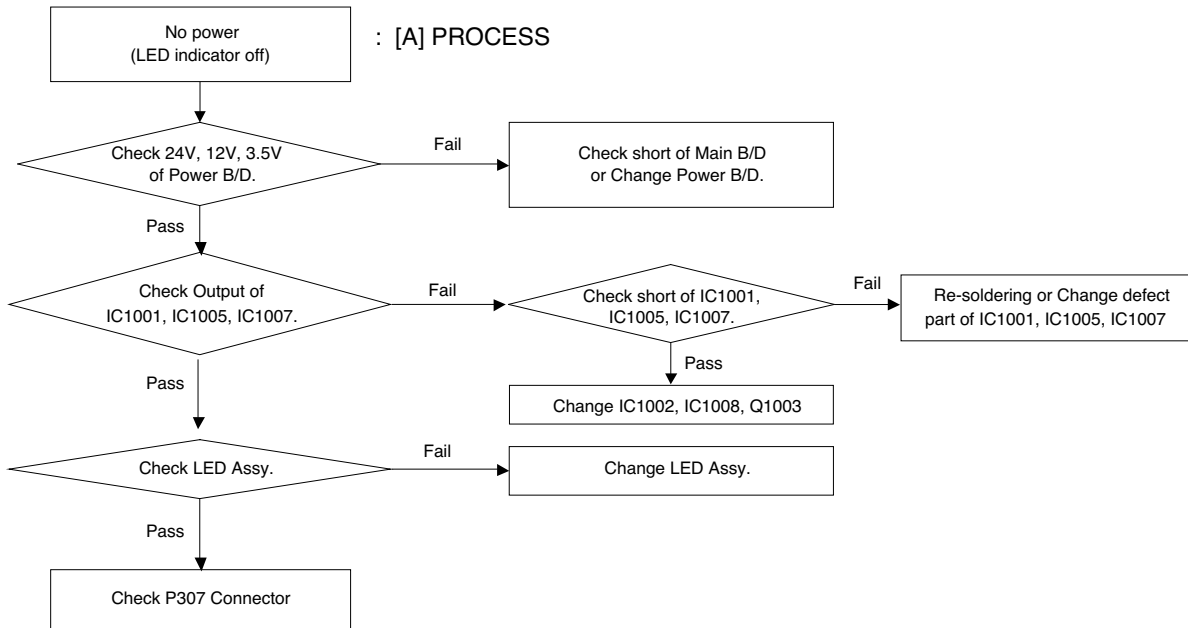

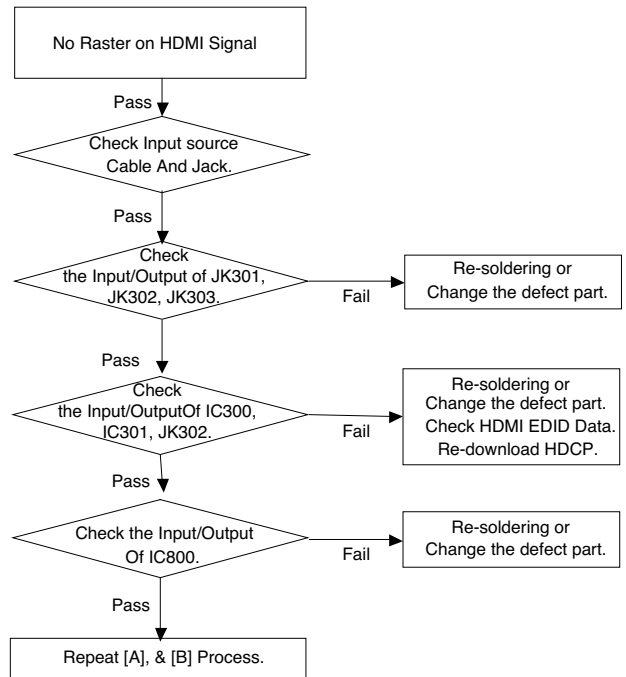
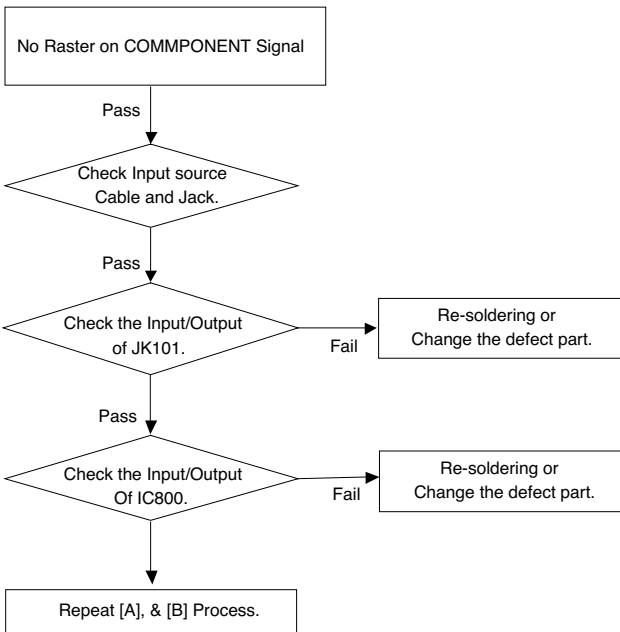
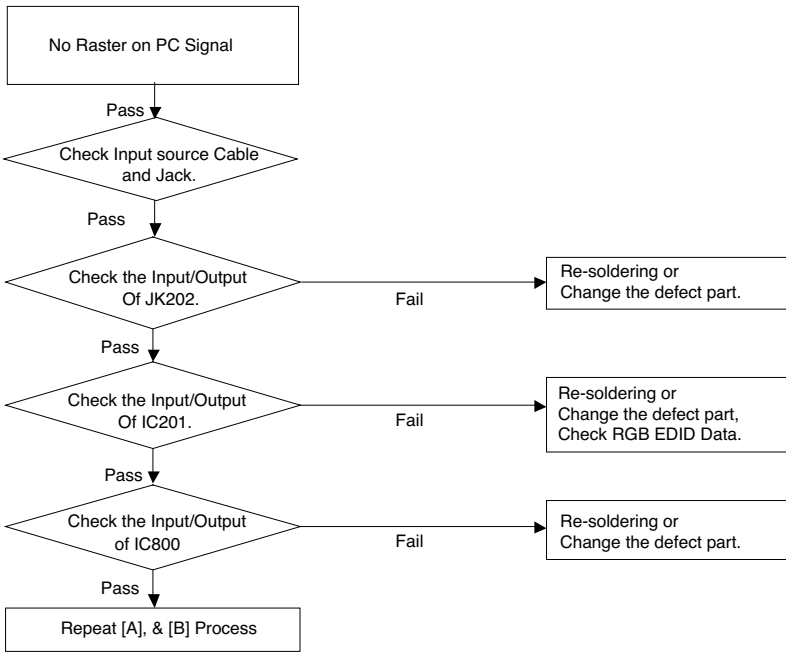

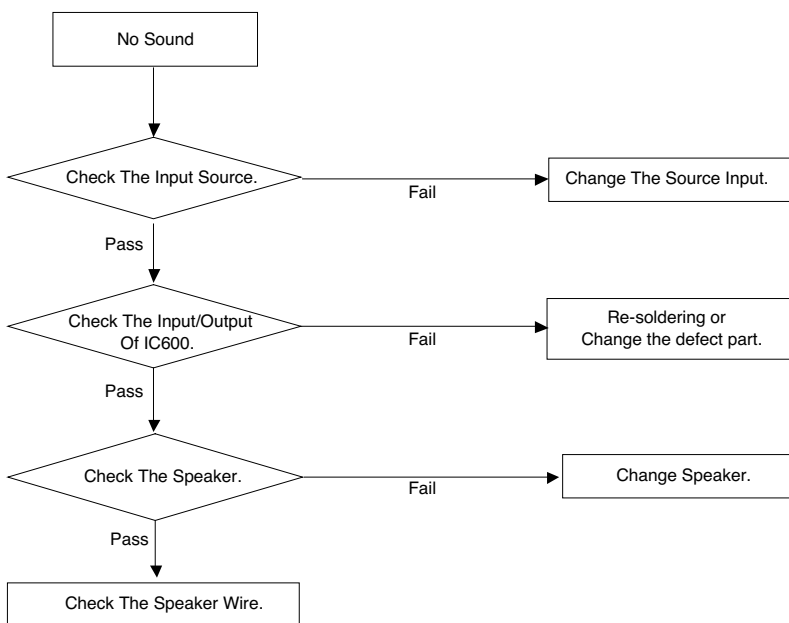
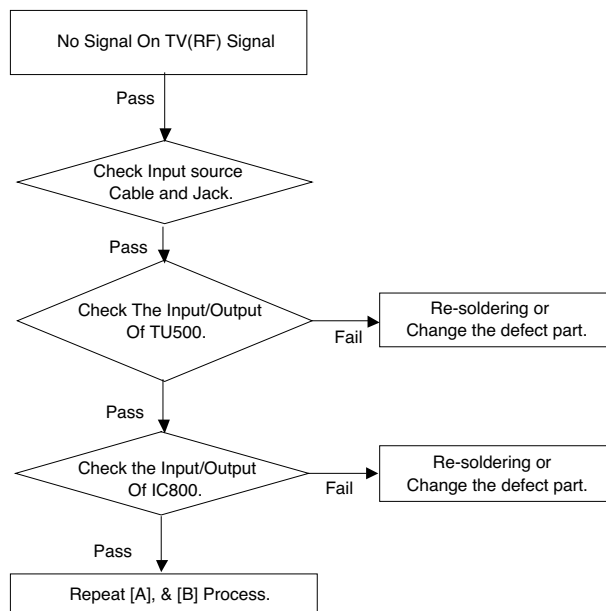
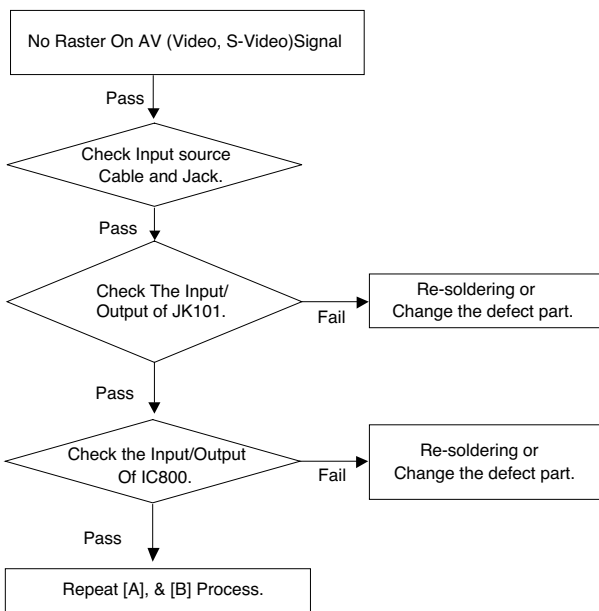

BLOCK DIAGRAM

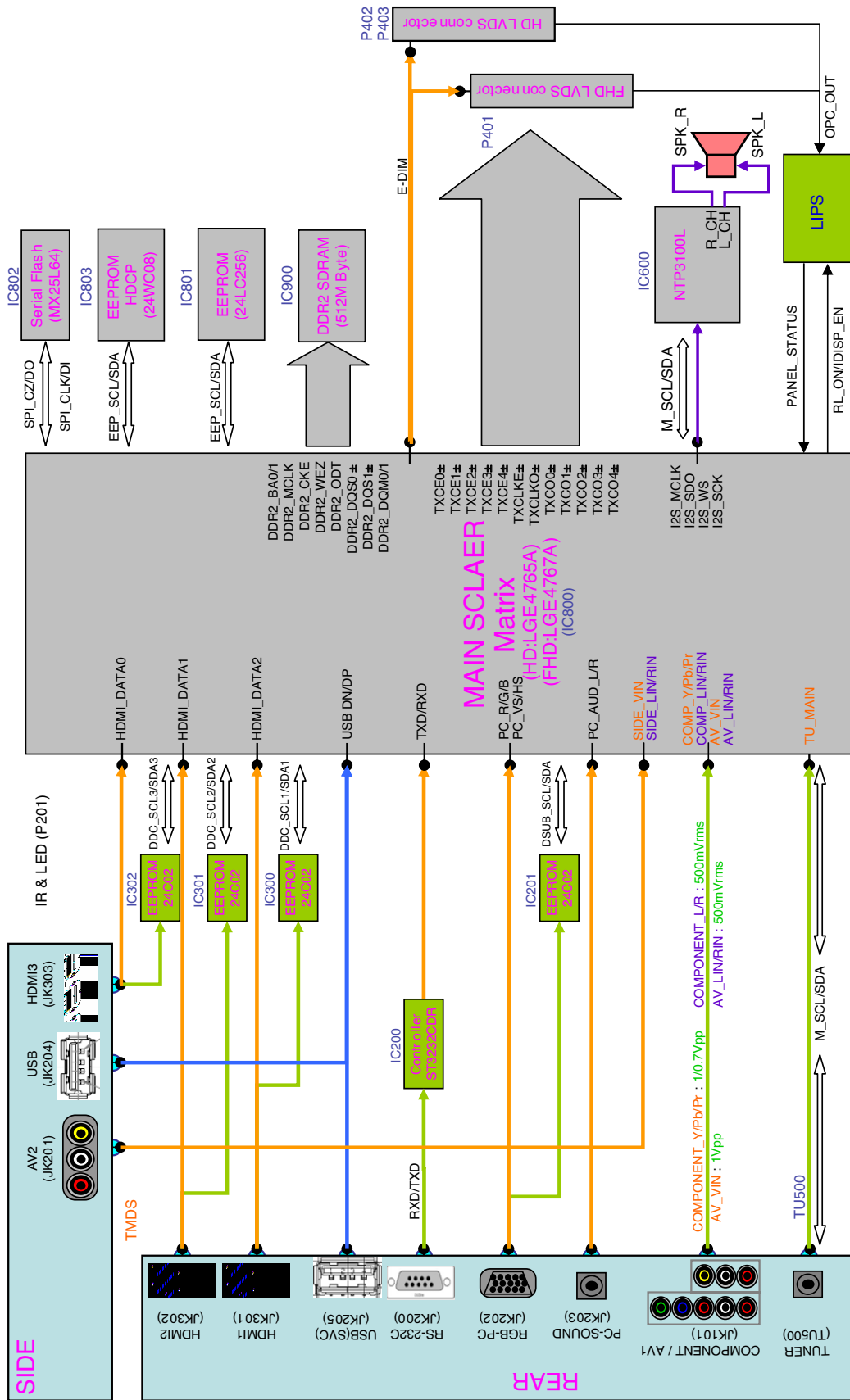

EXPLODED VIEW

IMPORTANT SAFETY NOTICE

Many electrical and mechanical parts in this chassis have special safety-related characteristics. These parts are identified by \triangle in the Schematic Diagram and EXPLODED VIEW. It is essential that these special safety parts should be replaced with the same components as recommended in this manual to prevent X-RADIATION, Shock, Fire, or other Hazards. Do not modify the original design without permission of manufacturer.

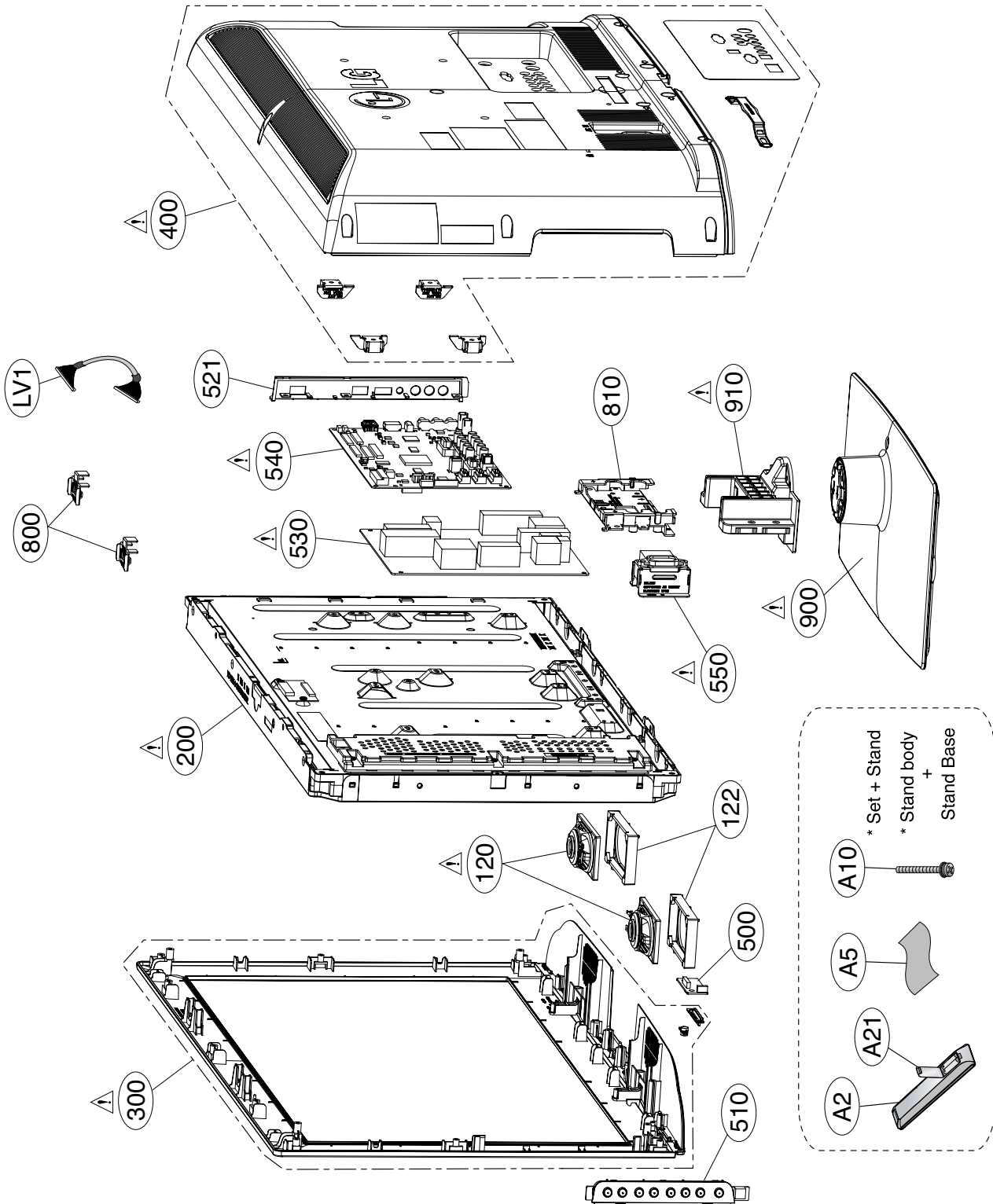

COMPONENT / AV IN

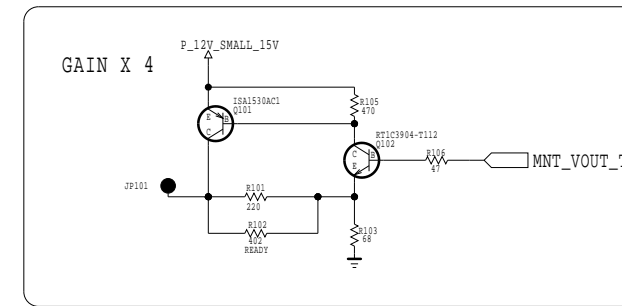
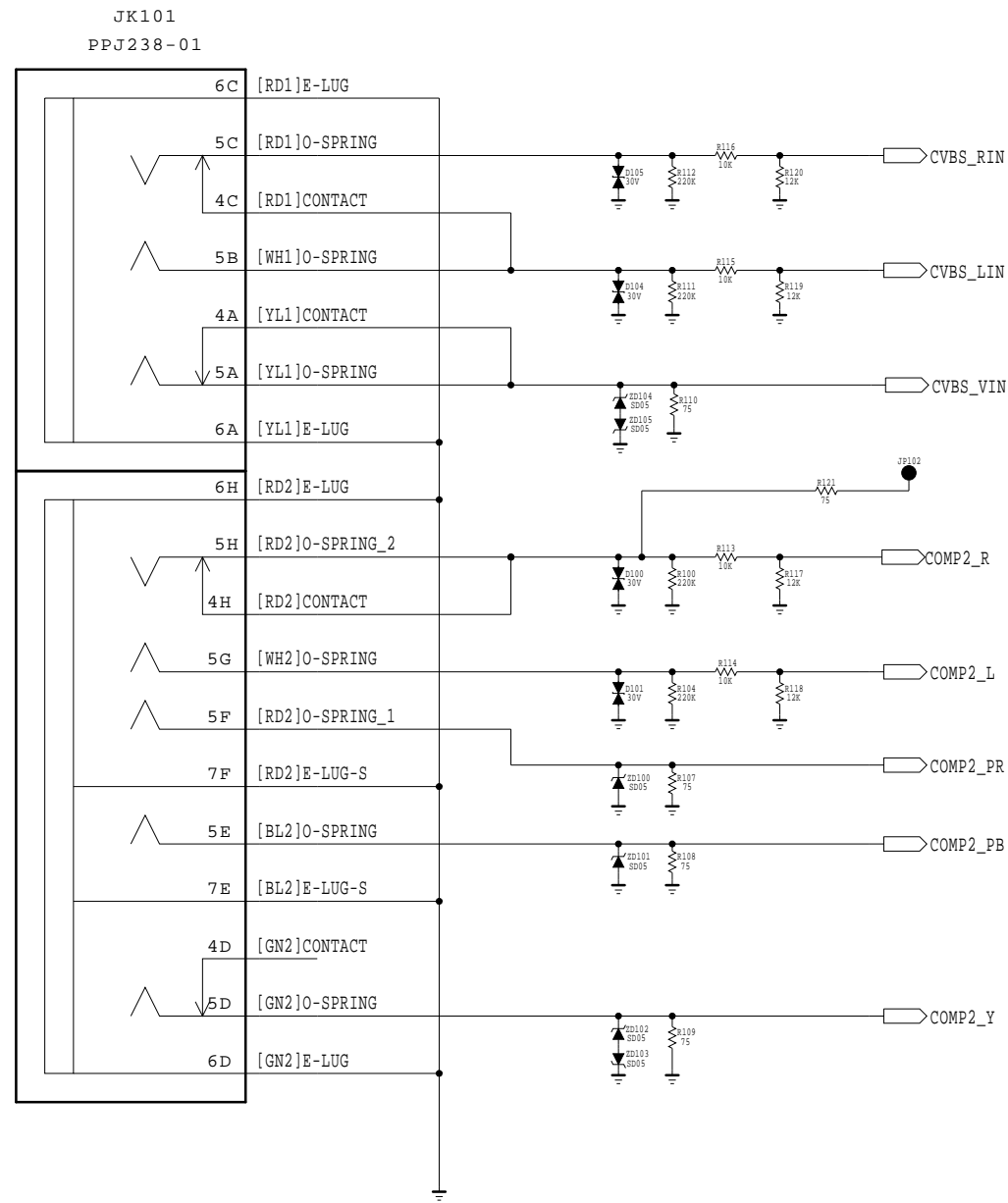

THE Δ SYMBOL MARK OF THIS SCHEMATIC DIAGRAM INCORPORATES SPECIAL FEATURES IMPORTANT FOR PROTECTION FROM X-RADIATION. FILRE AND ELECTRICAL SHOCK HAZARDS, WHEN SERVICING IF IS ESSENTIAL THAT ONLY MANUFACTURES SPECIFIED PARTS BE USED FOR THE CRITICAL COMPONENTS IN THE Δ SYMBOL MARK OF THE SCHEMATIC.

SECRET
LGElectronics



MODEL	LD330/LD420	DATE	2009/12/23
BLOCK	INPUT1	SHEET	1 / 9

RS-232C

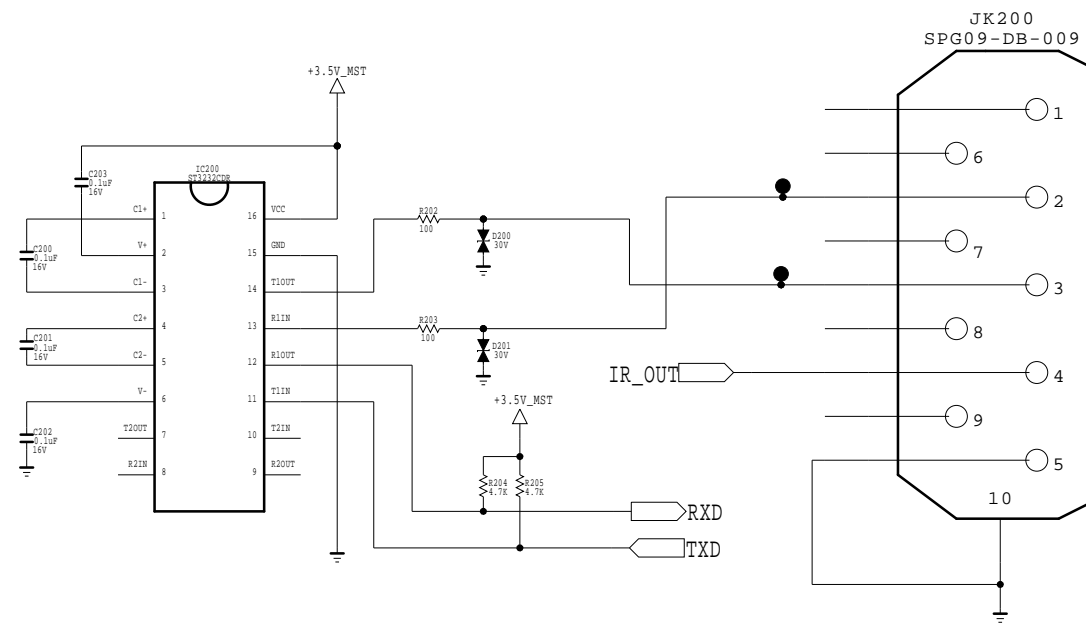

SIDE AV

SIDE_AV
JK201
PPJ235-01

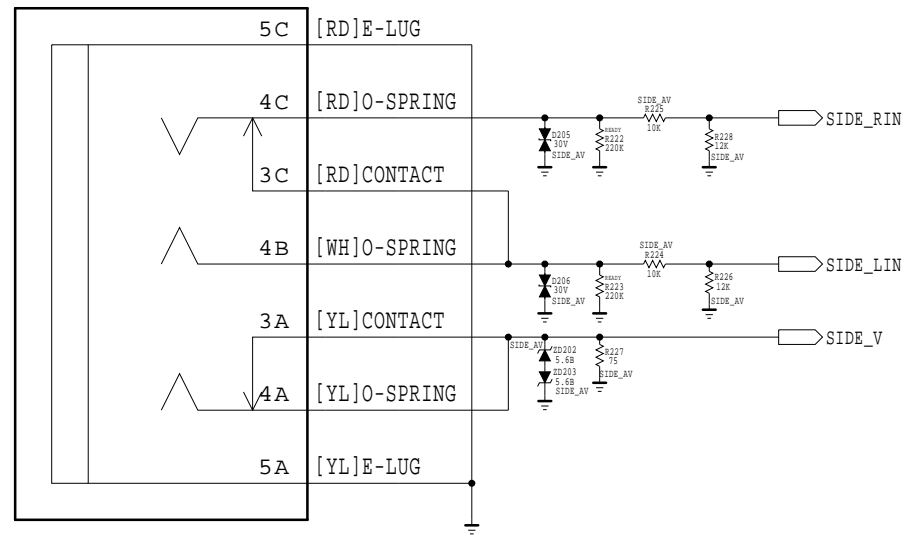

USB

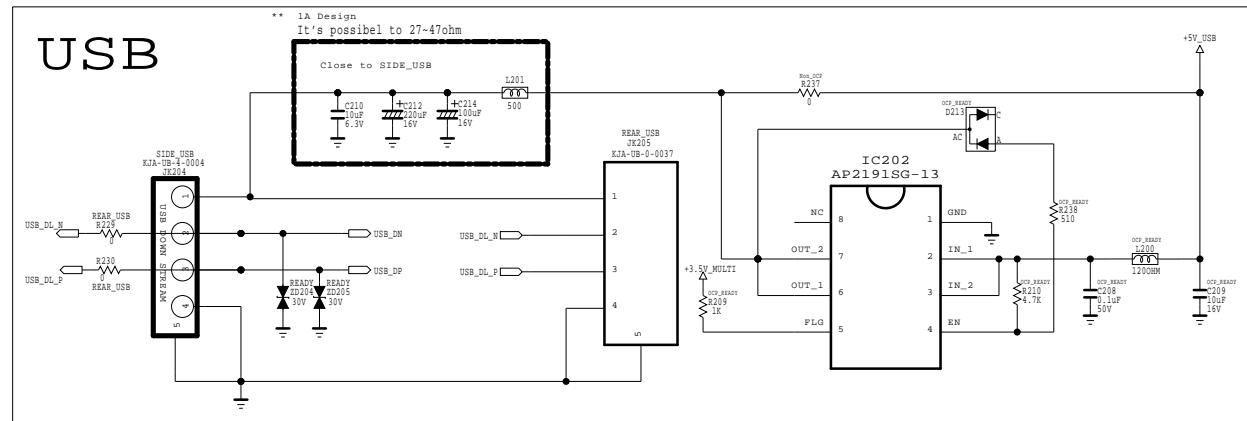

PC

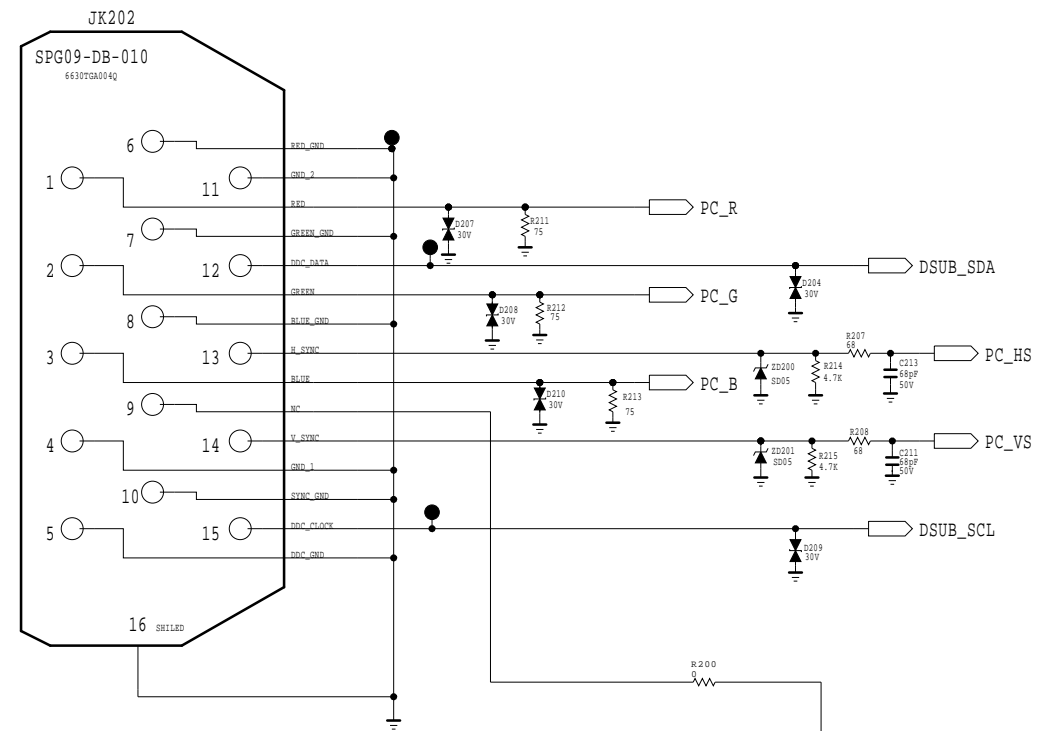

PC EDID

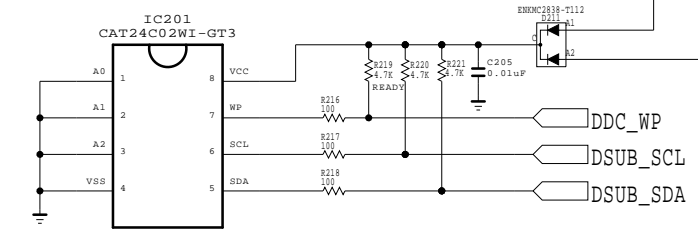

PC SOUND

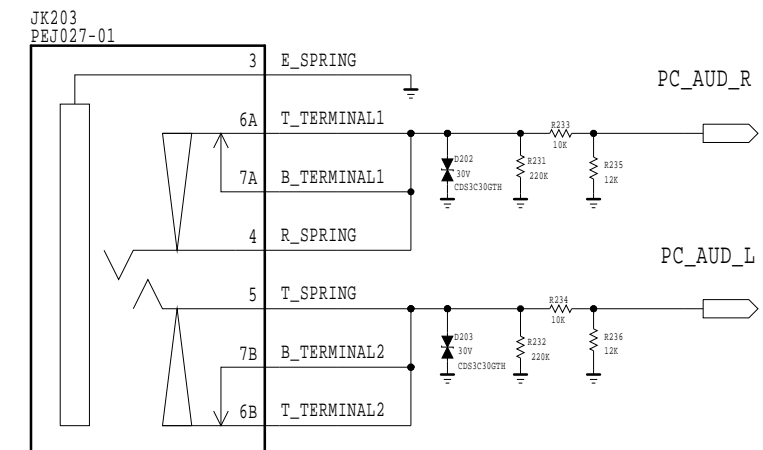

THE SYMBOL MARK OF THIS SCHEMATIC DIAGRAM INCORPORATES SPECIAL FEATURES IMPORTANT FOR PROTECTION FROM X-RADIATION. FILRE AND ELECTRICAL SHOCK HAZARDS, WHEN SERVICING IF IS ESSENTIAL THAT ONLY MANUFACTURES SPECIFIED PARTS BE USED FOR THE CRITICAL COMPONENTS IN THE SYMBOL MARK OF THE SCHEMATIC.

SECRET
LGElectronics



MODEL	LD330/LD420	DATE	2009/12/23
BLOCK	INPUT2	SHEET	2 / 9

OPTION
SW_HPD : USE SW HPD (Default)
MST_HPD : USE MST HPD

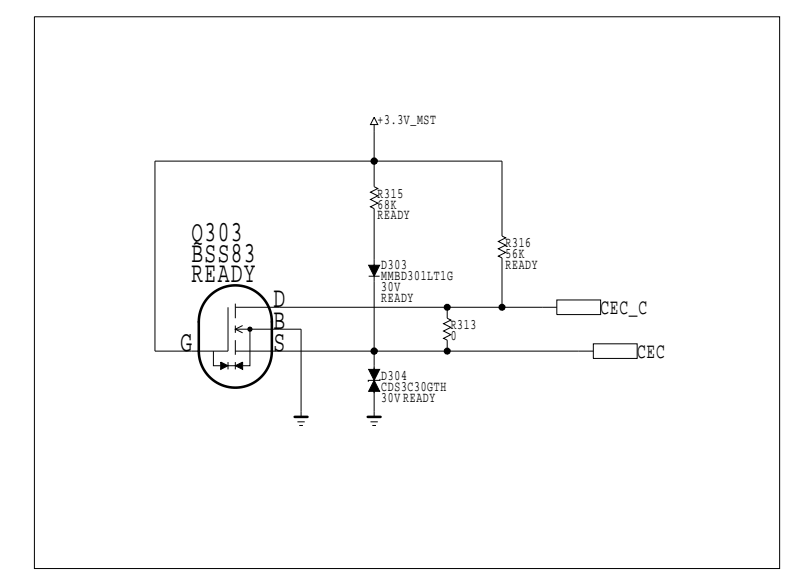
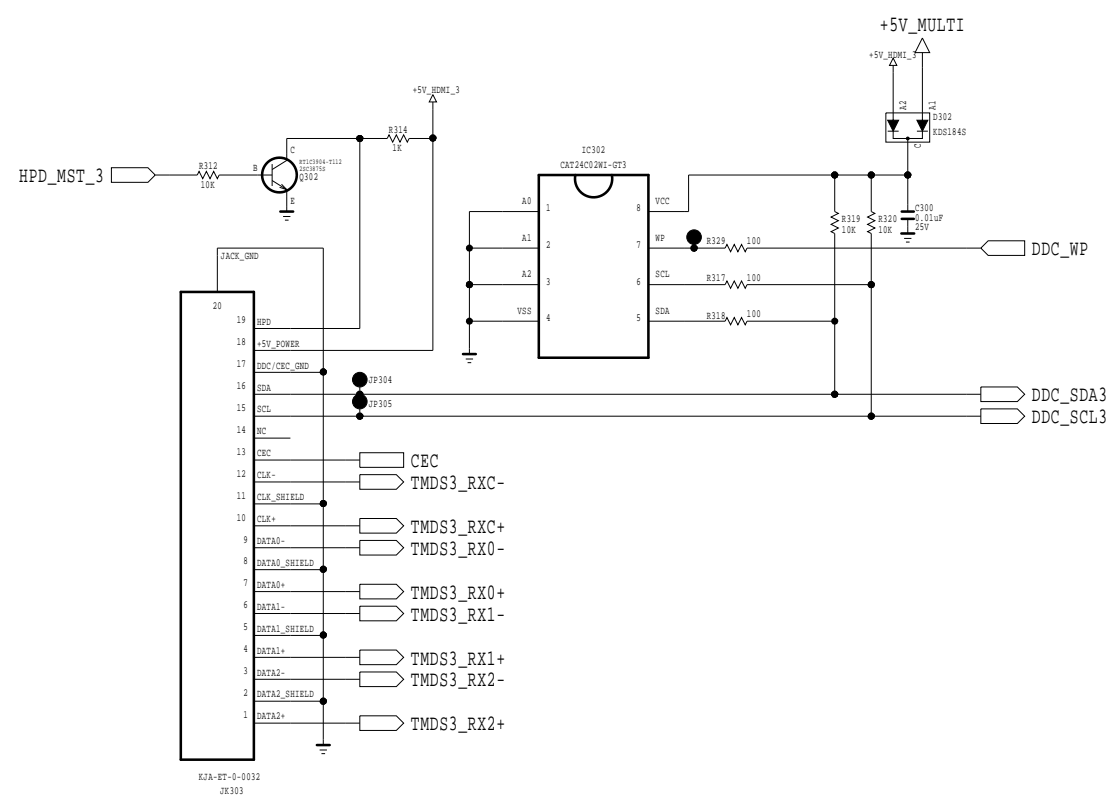
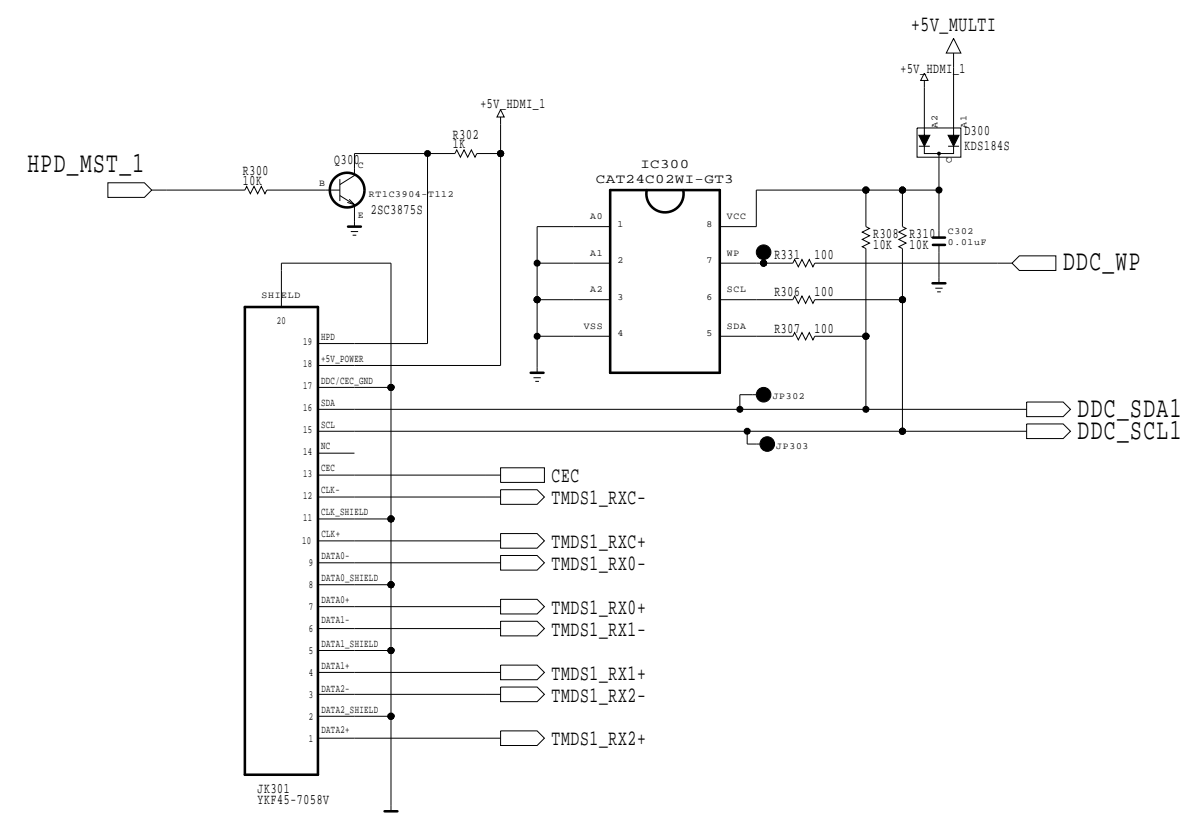
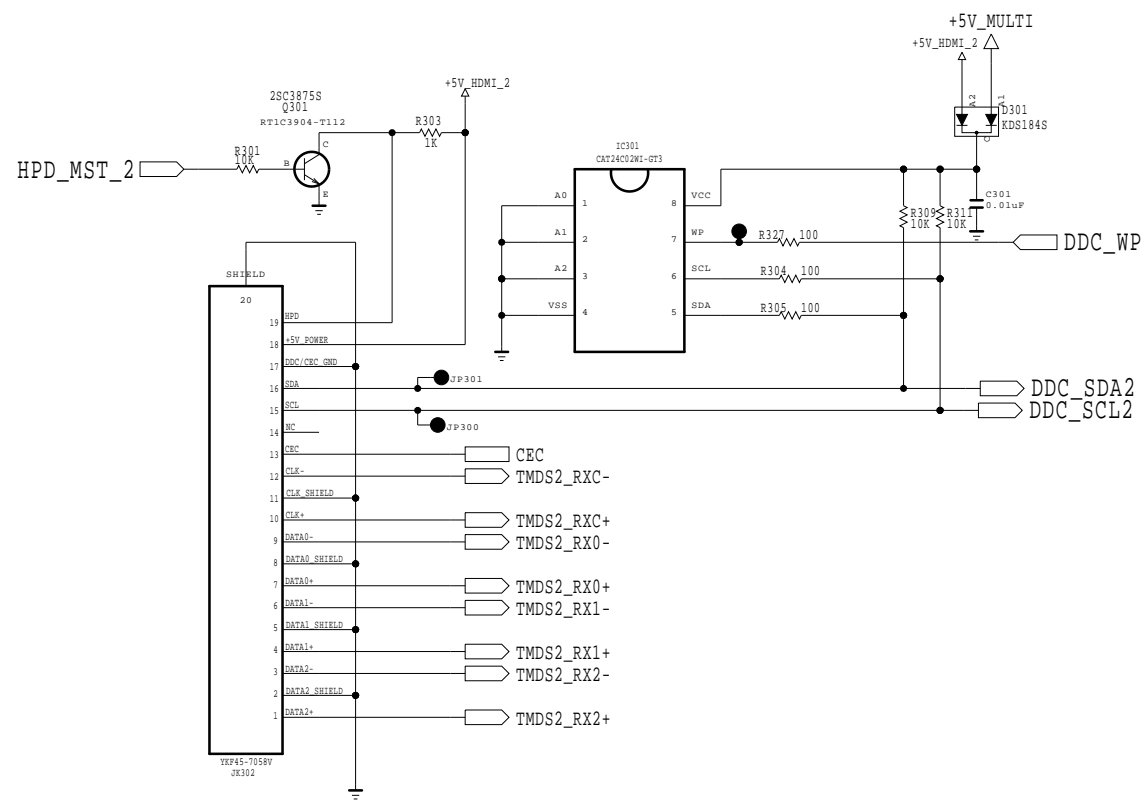

THE Δ SYMBOL MARK OF THIS SCHEMATIC DIAGRAM INCORPORATES SPECIAL FEATURES IMPORTANT FOR PROTECTION FROM X-RADIATION. FILRE AND ELECTRICAL SHOCK HAZARDS, WHEN SERVICING IF IS ESSENTIAL THAT ONLY MANUFACTURES SPECIFIED PARTS BE USED FOR THE CRITICAL COMPONENTS IN THE Δ SYMBOL MARK OF THE SCHEMATIC.

SECRET
LGElectronics



MODEL	LD330/LD420	DATE	2009/12/23
BLOCK	HDMI	SHEET	3 / 9

PANEL WAFER

TXCB0+, TXCB0-, TXCB1+, TXCB1-, TXCB2+, TXCB2-, TXCB3+, TXCB3-, TXCB4+, TXCB4-, TXCLAE+, TXCLAE-, TXCLAO+, TXCLAO-, TXCO0+, TXCO0-, TXCO1+, TXCO1-, TXCO2+, TXCO2-, TXCO3+, TXCO3-, TXCO4+, TXCO4-

TXCB0+, TXCB0-, TXCB1+, TXCB1-, TXCB2+, TXCB2-, TXCB3+, TXCB3-, TXCB4+, TXCB4-, TXCLAE+, TXCLAE-

TXCB0+, TXCB0-, TXCB1+, TXCB1-, TXCB2+, TXCB2-

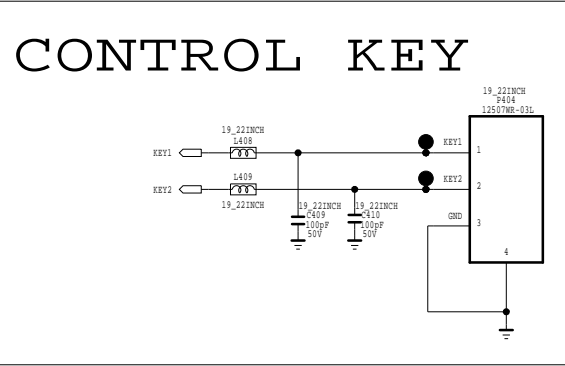
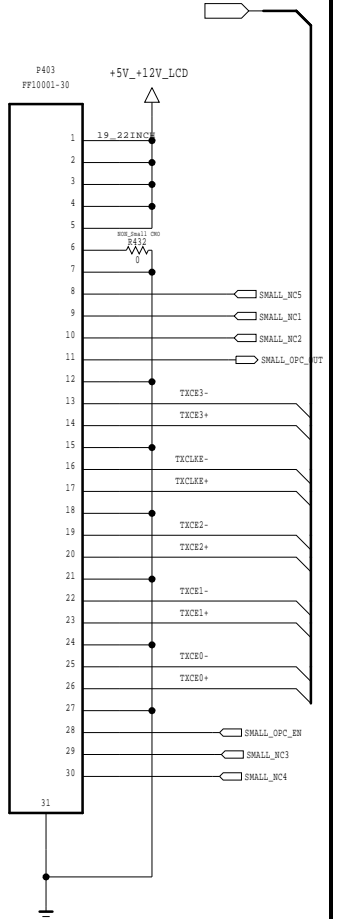
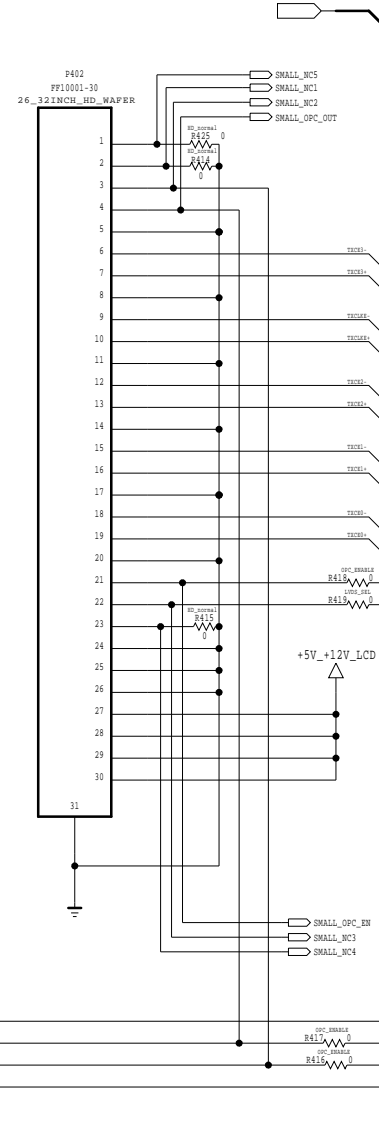
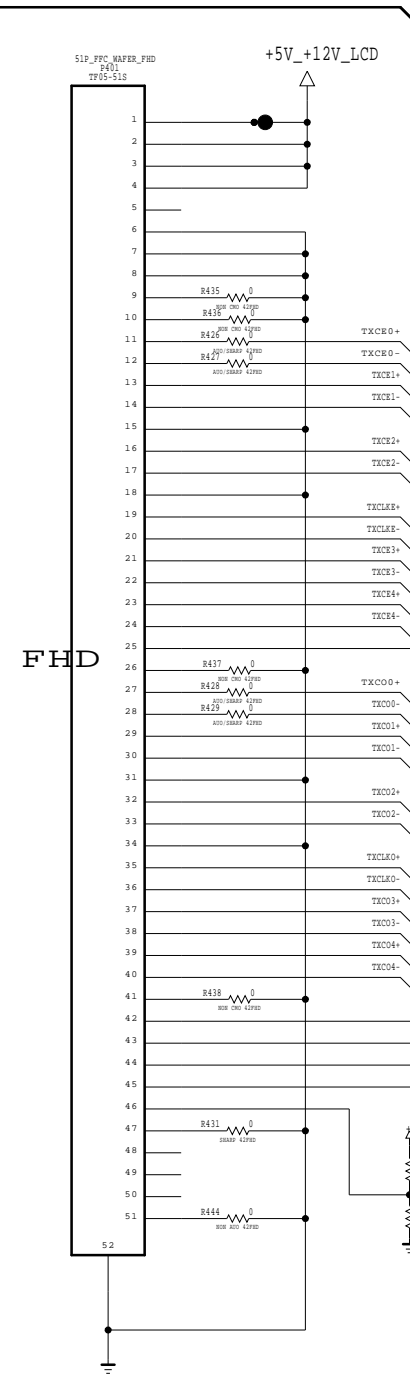
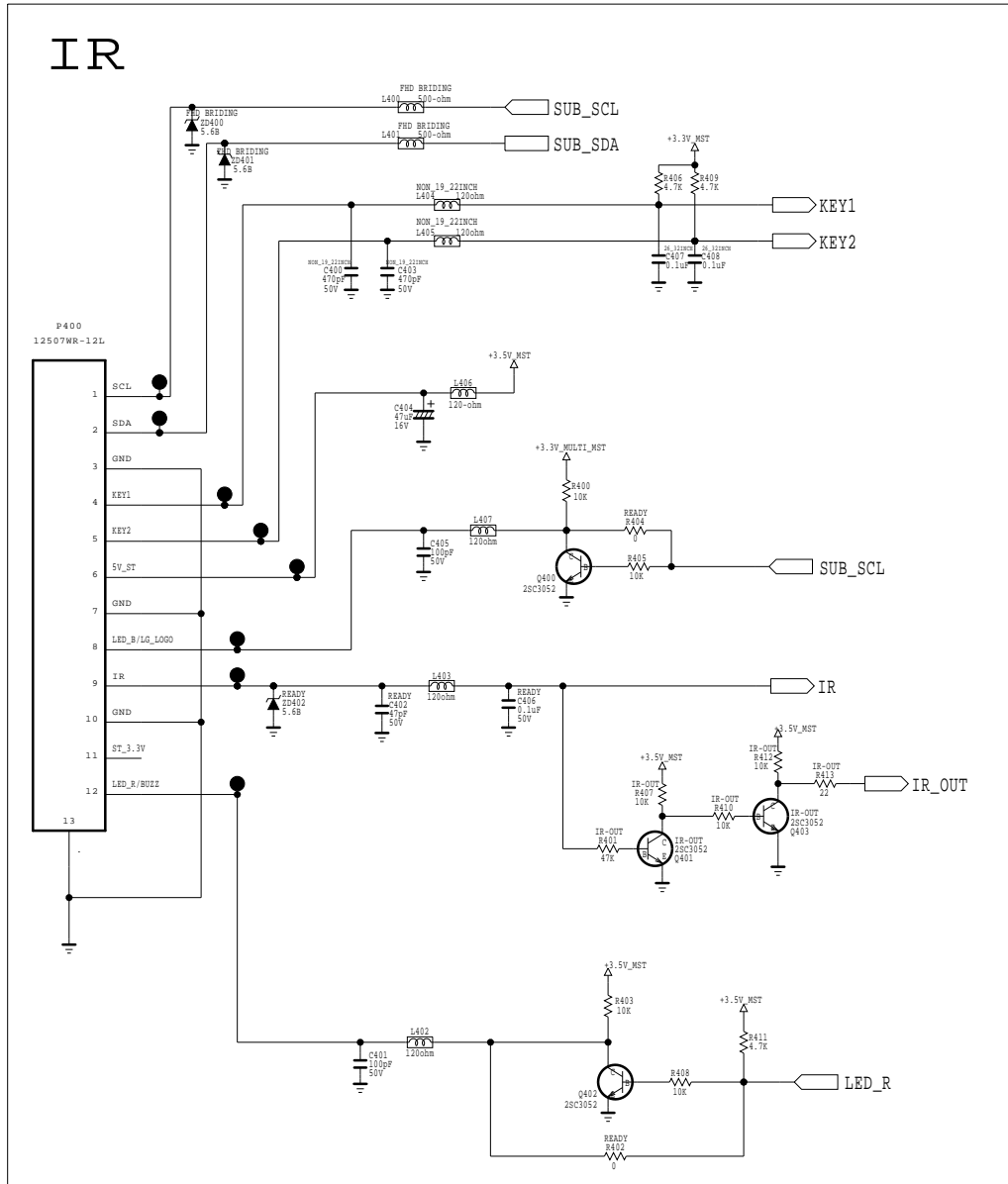

	R444	R443	R442	R441	R440	R439	R438	R437	R436	R435
SHARP 32INCH FHD	0	X	X	VESA	X	X	X	0	0	0
IPS 32INCH FHD	0	X	X	VESA	X	X	X	0	X	0
SHARP 32INCH FHD	0	0	0	0	0	0	0	0	0	0

**OPC_ENABLE : USE LGD Module

THE Δ SYMBOL MARK OF THIS SCHEMATIC DIAGRAM INCORPORATES SPECIAL FEATURES IMPORTANT FOR PROTECTION FROM X-RADIATION. FILRE AND ELECTRICAL SHOCK HAZARDS, WHEN SERVICING IF IS ESSENTIAL THAT ONLY MANUFACTURES SPECIFIED PARTS BE USED FOR THE CRITICAL COMPONENTS IN THE Δ SYMBOL MARK OF THE SCHEMATIC.

SECRET
LGElectronics



MODEL	LD330/LD420	DATE	2009/12/23
BLOCK	LVDS, CTR KEY	SHEET	4 / 9

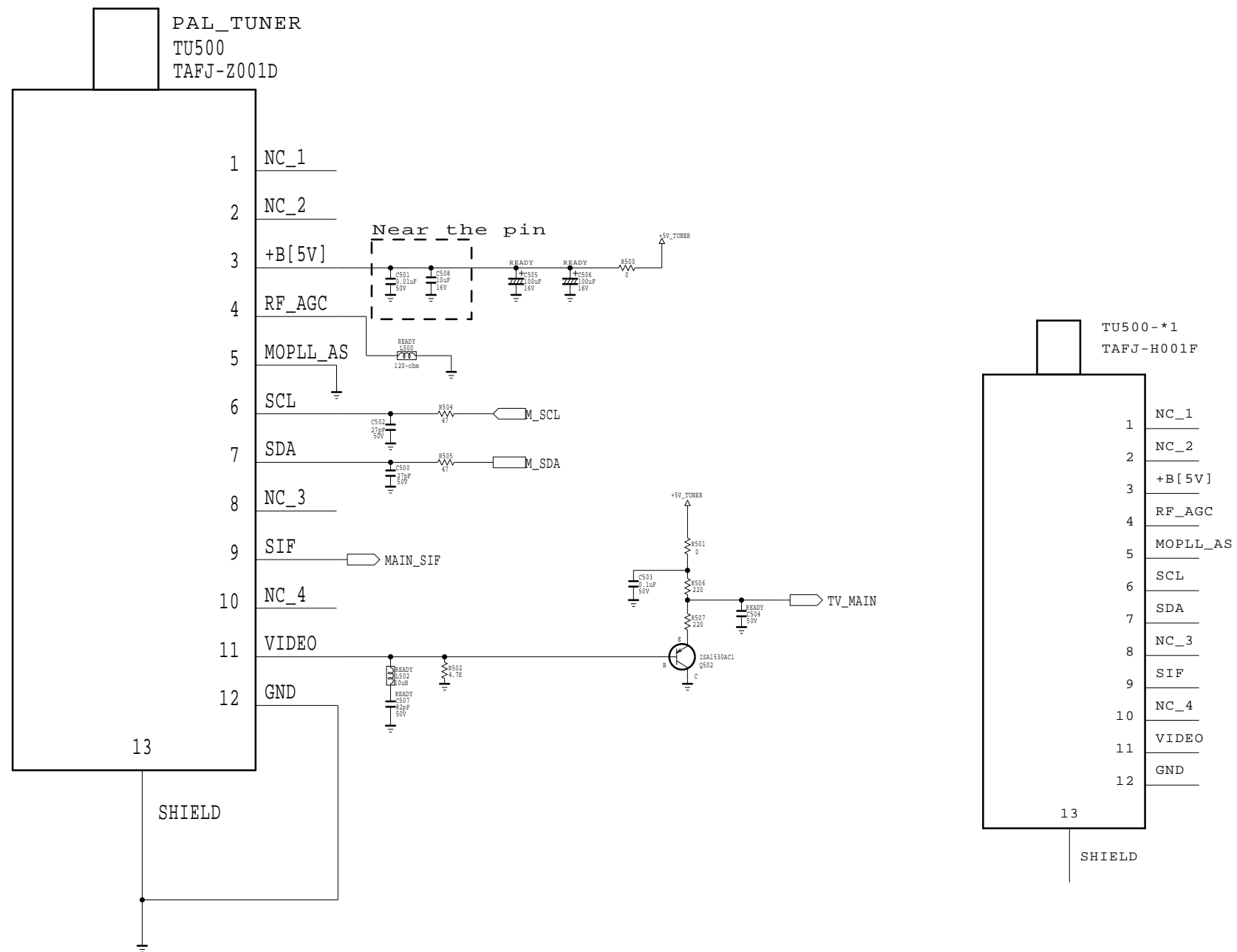

THE SYMBOL MARK OF THIS SCHEMATIC DIAGRAM INCORPORATES SPECIAL FEATURES IMPORTANT FOR PROTECTION FROM X-RADIATION. FILRE AND ELECTRICAL SHOCK HAZARDS, WHEN SERVICING IF IS ESSENTIAL THAT ONLY MANUFACTURES SPECIFIED PARTS BE USED FOR THE CRITICAL COMPONENTS IN THE SYMBOL MARK OF THE SCHEMATIC.

SECRET
LGElectronics



MODEL	LD330/LD420	DATE	2009/12/23
BLOCK	TUNER	SHEET	5 / 9

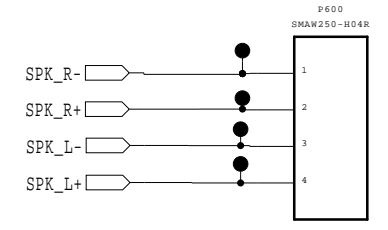
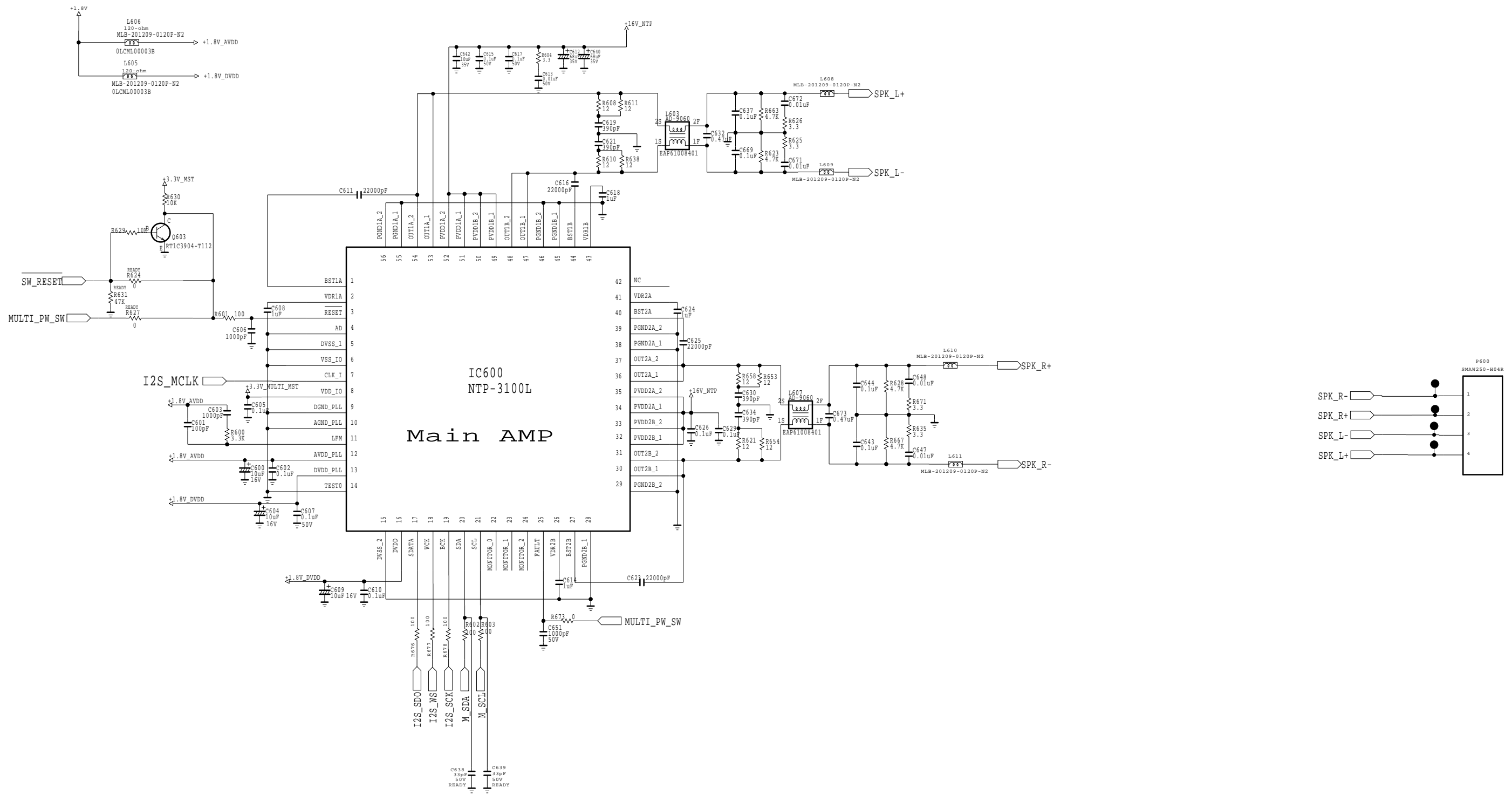

THE SYMBOL MARK OF THIS SCHEMATIC DIAGRAM INCORPORATES SPECIAL FEATURES IMPORTANT FOR PROTECTION FROM X-RADIATION. FILRE AND ELECTRICAL SHOCK HAZARDS, WHEN SERVICING IF IS ESSENTIAL THAT ONLY MANUFACTURES SPECIFIED PARTS BE USED FOR THE CRITICAL COMPONENTS IN THE SYMBOL MARK OF THE SCHEMATIC.

SECRET
LGElectronics



MODEL	LD330/LD420	DATE	2009/12/23
BLOCK	AUDIO	SHEET	6 / 9

EAX61532102 LP91H

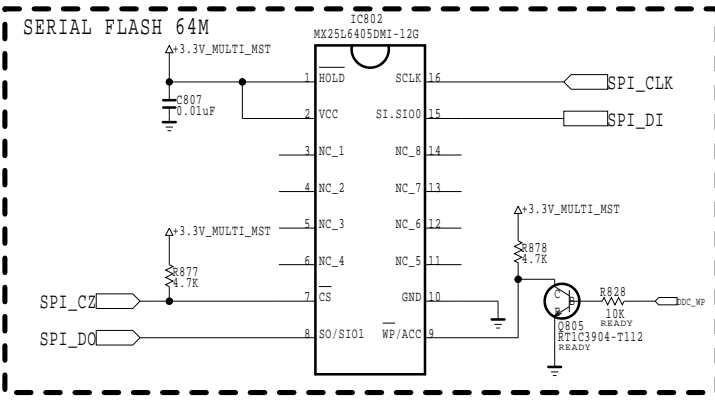

***H/W OPTION**

	R896	R898	R8010	R8011
Small HD	4.7K	X	4.7K	X
Small FHD (22")	4.7K	X	4.7K	4.7K
Non Small HD	4.7K	X	X	4.7K
LGD Joker	4.7K	4.7K	4.7K	X
26" FHD	4.7K	4.7K	4.7K	4.7K
O/S Joker	4.7K	4.7K	X	4.7K
Non Small FHD	X	4.7K	4.7K	X
Apollo	X	4.7K	4.7K	4.7K
100H2	X	4.7K	X	4.7K

** Small HD : 19/22/26 Inch
 ** Non Small FHD : Normal(non 100Hz) FHD Model
 ** LGD Joker : LP Series (10BIT FHD, LED ON/OFF)
 ** O/S Joker : LP Series (8BIT FHD, LED ON/OFF)
 ** Small FHD (22") : 8BIT,LED ON/OFF
 ** 26" FHD : 10BIT,LED ON/OFF

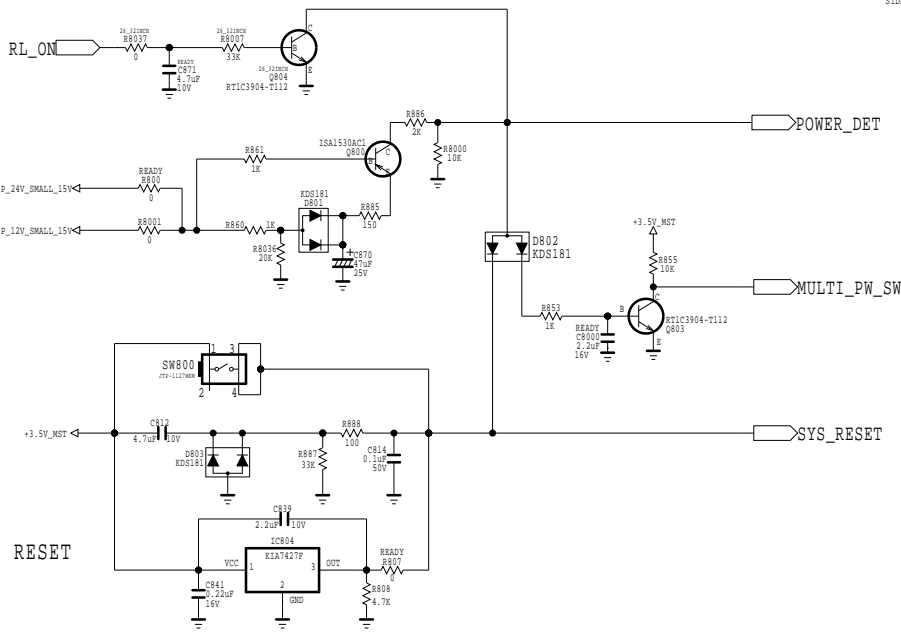
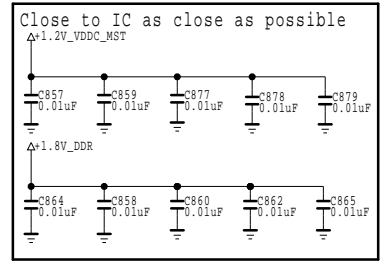
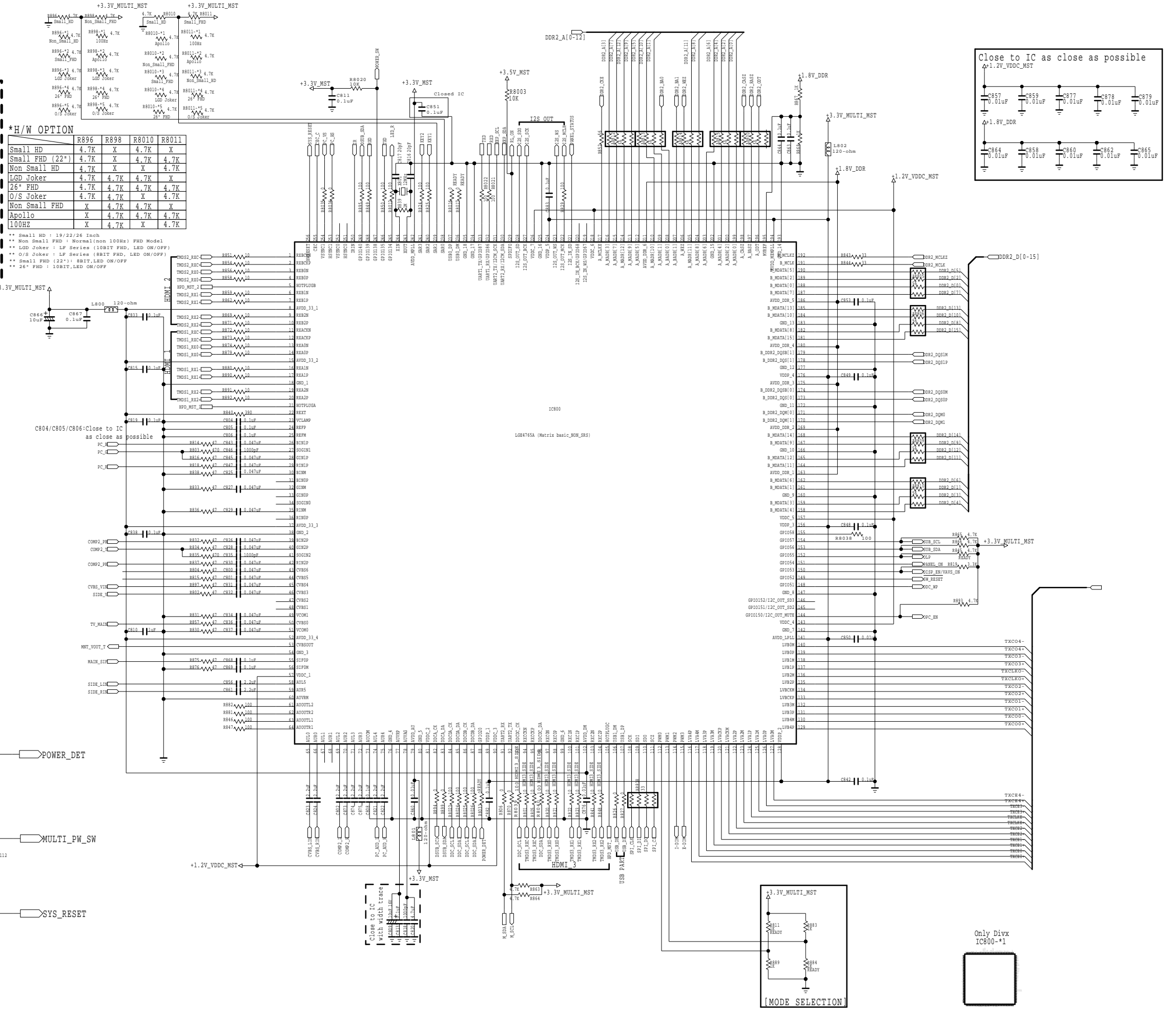
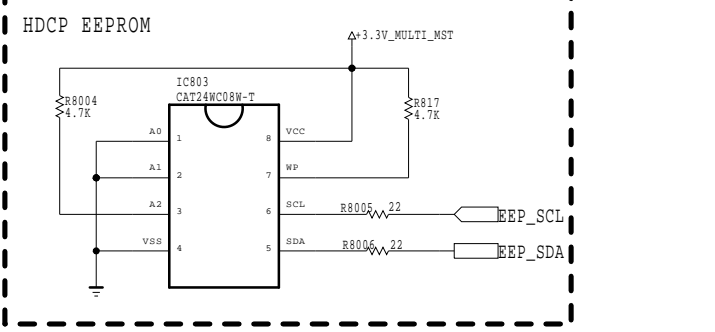
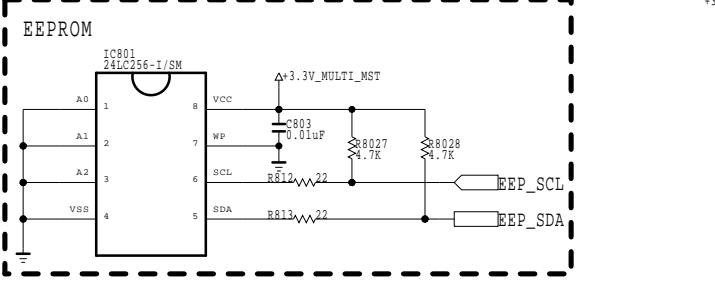

THE Δ SYMBOL MARK OF THIS SCHEMATIC DIAGRAM INCORPORATES SPECIAL FEATURES IMPORTANT FOR PROTECTION FROM X-RADIATION. FILRE AND ELECTRICAL SHOCK HAZARDS, WHEN SERVICING IF IS ESSENTIAL THAT ONLY MANUFACTURES SPECIFIED PARTS BE USED FOR THE CRITICAL COMPONENTS IN THE Δ SYMBOL MARK OF THE SCHEMATIC.

SECRET
LGElectronics



MODEL	LD330/LD420	DATE	2009/12/23
BLOCK	MSTAR	SHEET	7 / 9

DDR2

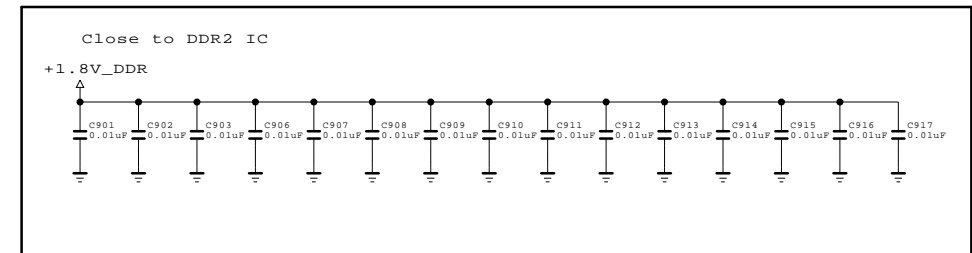
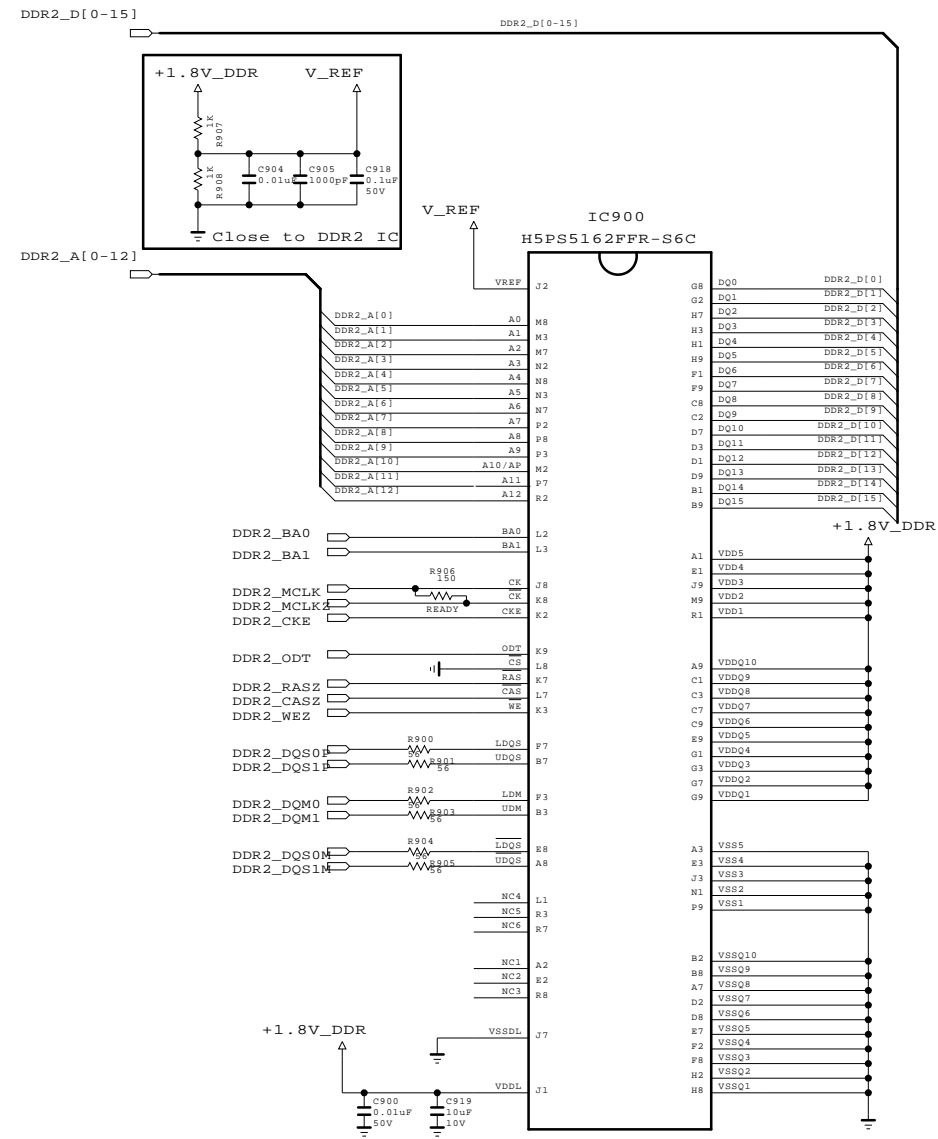

DDR2 MEMORY

THE SYMBOL MARK OF THIS SCHEMATIC DIAGRAM INCORPORATES SPECIAL FEATURES IMPORTANT FOR PROTECTION FROM X-RADIATION. FILRE AND ELECTRICAL SHOCK HAZARDS, WHEN SERVICING IF IS ESSENTIAL THAT ONLY MANUFACTURES SPECIFIED PARTS BE USED FOR THE CRITICAL COMPONENTS IN THE SYMBOL MARK OF THE SCHEMATIC.

SECRET
LGElectronics



MODEL	LD330/LD420	DATE	2009/12/23
BLOCK	DDR2	SHEET	8 / 9

EAX61532102 LP91H

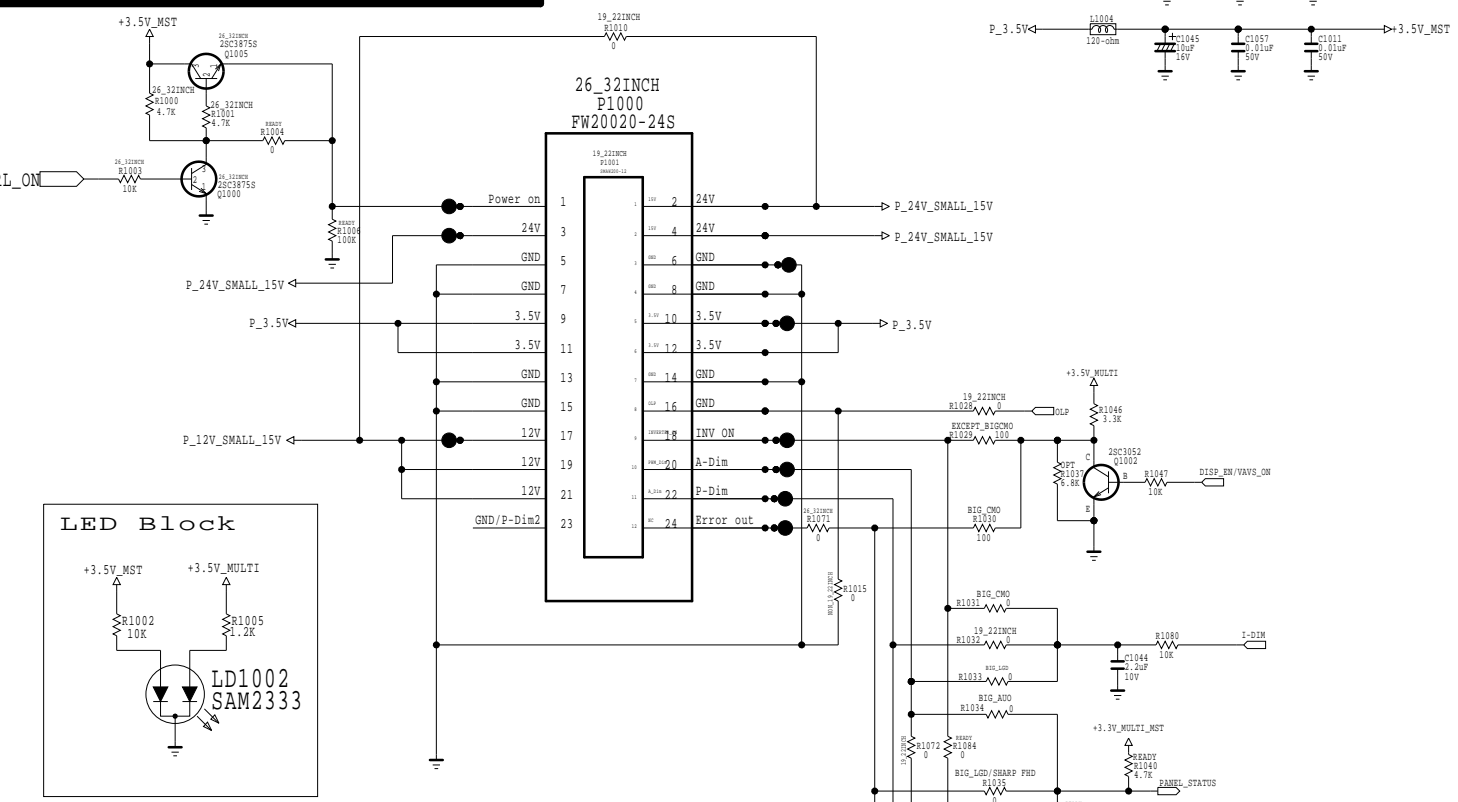

<OS MODULE PIN MAP>

PIN No	LGD	CMO(09)	AUO	SHARP	IPS	SMALL
18	INV_ON	A-DIM	INV_ON	INV_ON	INV_ON	INV_ON
20	V4-YBB-A V5-YBB-A	Err_out	Err_out	NC	Err_out	PWM_DIM
22	PWM_DIM	PWM_DIM	NC	PWM_DIM	NC	A-DIM
24	Err_out	INV_ON	PWM_DIM	GND	PWM_DIM	NC

**5V_MULTI->3.3V->1.2V

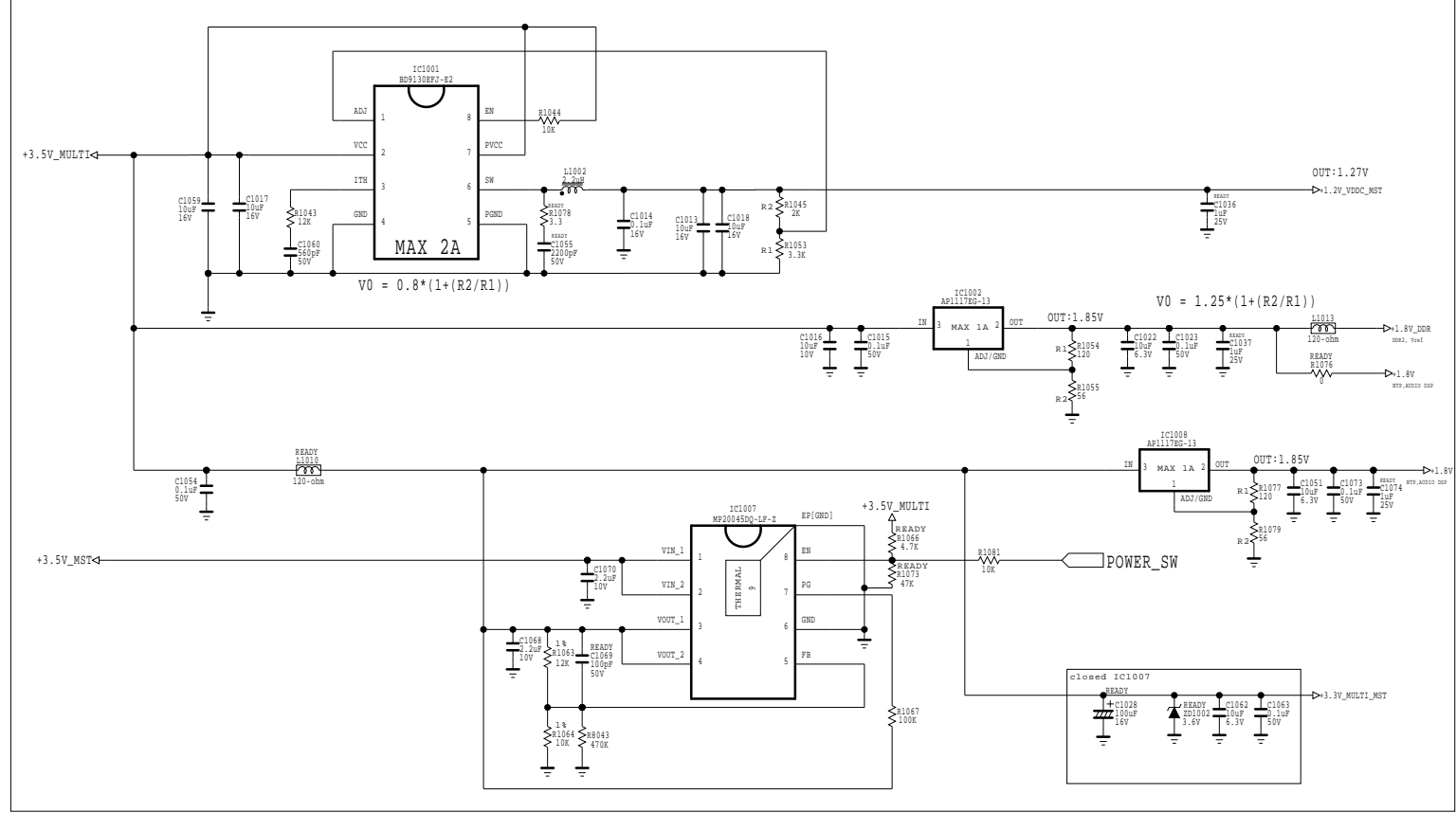

**Switch 12V:P12V **Switch 3.5V:3.5.V_MULTI

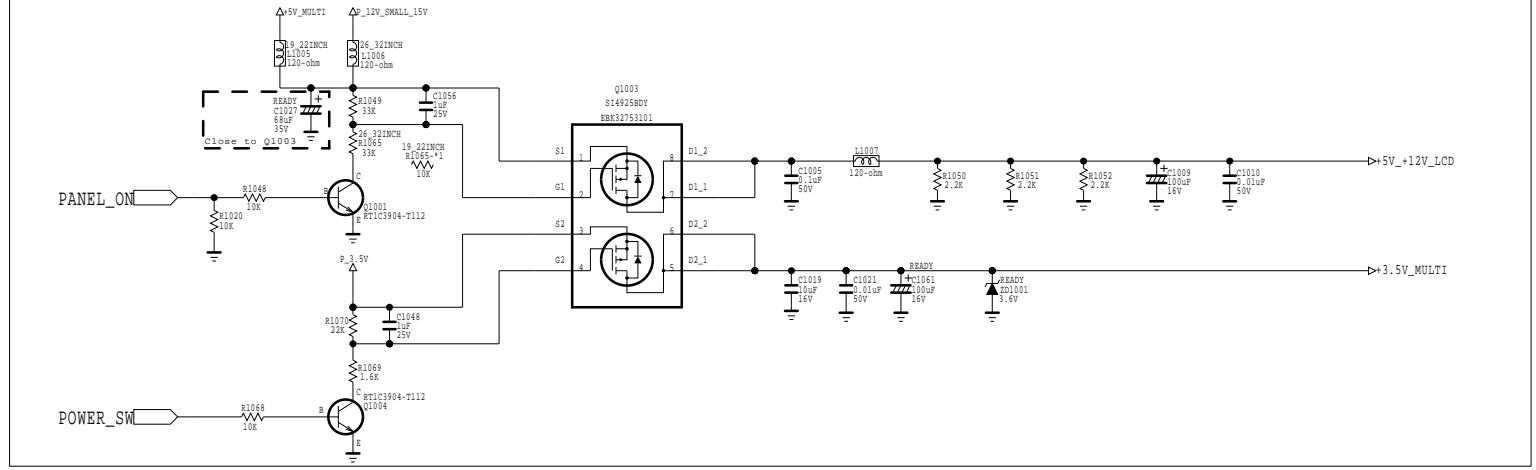

*ST 3.5V->3.3V

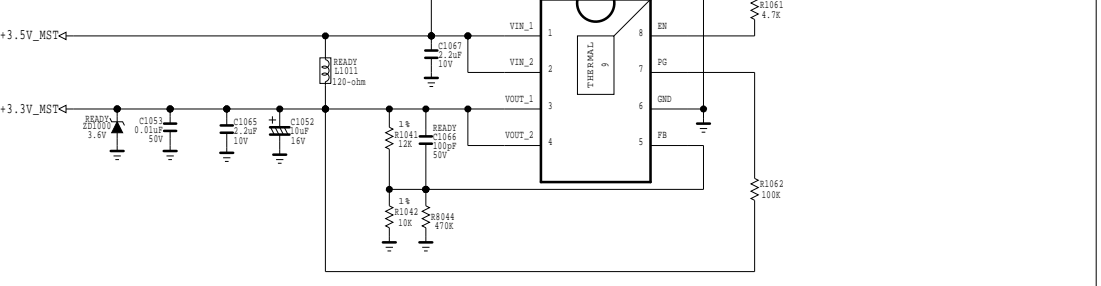

**DC-DC CONVERTER *12V -> 5V_MULTI

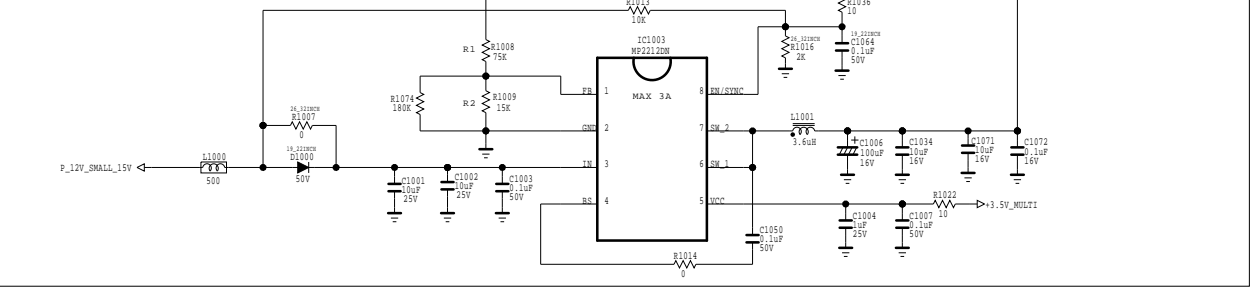

**DC-DC CONVERTER *12V->TUNER 5V

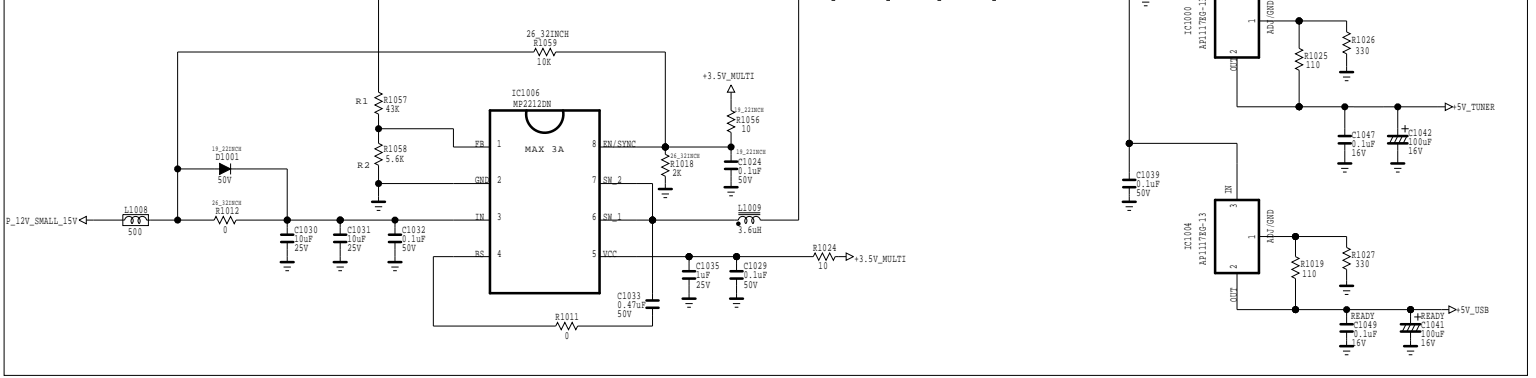

THE Δ SYMBOL MARK OF THIS SCHEMATIC DIAGRAM INCORPORATES SPECIAL FEATURES IMPORTANT FOR PROTECTION FROM X-RADIATION. FILRE AND ELECTRICAL SHOCK HAZARDS, WHEN SERVICING IF IS ESSENTIAL THAT ONLY MANUFACTURES SPECIFIED PARTS BE USED FOR THE CRITICAL COMPONENTS IN THE Δ SYMBOL MARK OF THE SCHEMATIC.

SECRET
LGElectronics



MODEL	LD330/LD420	DATE	2009/12/23
BLOCK	POWER	SHEET	9 / 9

