

**SAMSUNG**

# COLOR TELEVISION RECEIVER

Chassis : K55A(P)

Model : WS32Z46VSGXEC  
WS32Z46VSGXXEU

# **SERVICE** *Manual*

## COLOR TELEVISION RECEIVER

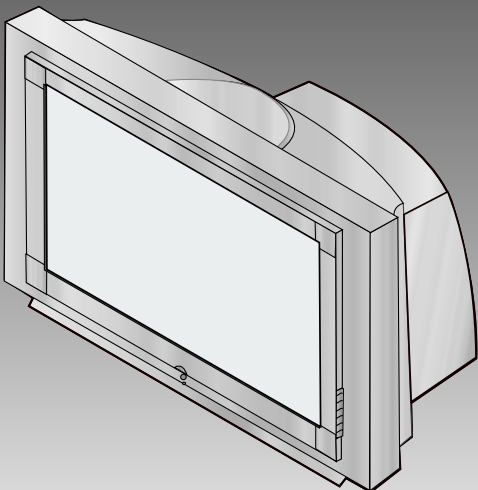

## CONTENTS

1. Precautions
2. Reference Information
3. Specifications
4. Alignment and Adjustments
5. Troubleshooting
6. Exploded Views and Parts List
7. Electrical Parts List
8. Block Diagrams
9. Schematic Diagrams

## 4. Alignment and Adjustments

### 4-1 Adjustments

#### 4-1-1 General Alignment Instructions

Usually, a color TV needs only slight touch-up adjustment upon installation. Check the basic characteristics such as vertical size, horizontal size, and focus. Observe the picture and check for good black and white details. There must be no objectionable color shading: If color shading is present, demagnetize the receiver. If color shading persists, re-do purity and convergence adjustments.

**Note :**

1. This '4. Alignment and Adjustments' applies to K55A chassis applications.
2. AC Power Supply: 160~300V or 100~240V, 50Hz
3. This service manual has been written on the basis of domestic remote-control model adopting K55A chassis. Depending on sales location and product specifications, some of specifications herein may be changed.

#### 4-1-2 Focus Adjustment

K55A contains a dynamic focus circuit. When CRT PCB, FBT or CRT is replaced, be sure to adjust in the following sequence:

##### Dynamic Focus Adjustment

1. Input a crosshatch pattern.
2. Select "Standard" from the menu,
3. Turn the Static Focus VR clockwise to set it to its maximum.
4. Turn the Dynamic Focus VR counterclockwise to set it to its maximum.
5. Turn the Static Focus VR counterclockwise slowly for the clearest center vertical line.

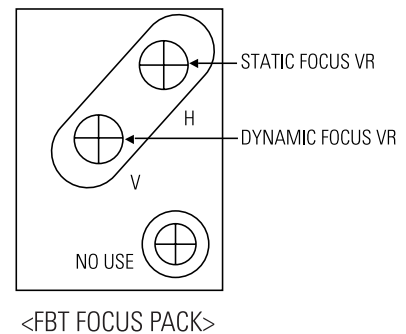

6. Turn the Dynamic Focus VR clockwise slowly for the clearest third line.

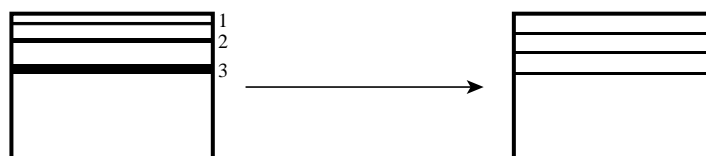

7. Check for the FOCUS of entire screen. If necessary, re-do adjustments 3~6.

### 4-1-3 Screen Voltage Adjustment

1. Input a Toshiba pattern.
2. Use an oscilloscope to identify RK, BK, GK. And then adjust FBT Screen VR so that the voltage of pedestal level doesn't exceed 160V.  
 If a Toshiba pattern is not available, cancel the blue screen and input "No Signal" to AV IN so the voltage of pedestal level doesn't exceed 175V.  
 If an oscilloscope is not available, use a DC multi-meter in No Signal (black screen) to adjust RK, BK, GK so that the highest voltage becomes 160Vp-p.

### 4-1-4 White Balance Adjustment

1. Warm up the TV set for at least 30 minutes.
2. Enter the Service Mode by pressing the remote control keys in the following sequence:  
 Power Off → Display → Menu → Mute → Power On
3. Initialize all set data.
4. Input a Toshiba pattern.
5. Using a probe(CA100), do the White Balance adjustments.
  - (1) Adjust Low-Light.
    - Adjust Sub Brightness to set Y.
    - Adjust B Cutoff to set y.
    - Adjust R Cutoff to set x.
  - (2) Adjust High-Light.
    - Adjust Sub Contrast to set Y.
    - Adjust B Drive to set y.
    - Adjust R Drive to set x.
  - (3) Check the value of Low-Light. If necessary, readjust Low-Light.
  - (4) Check the value of High-Light. If necessary, readjust High-Light.15

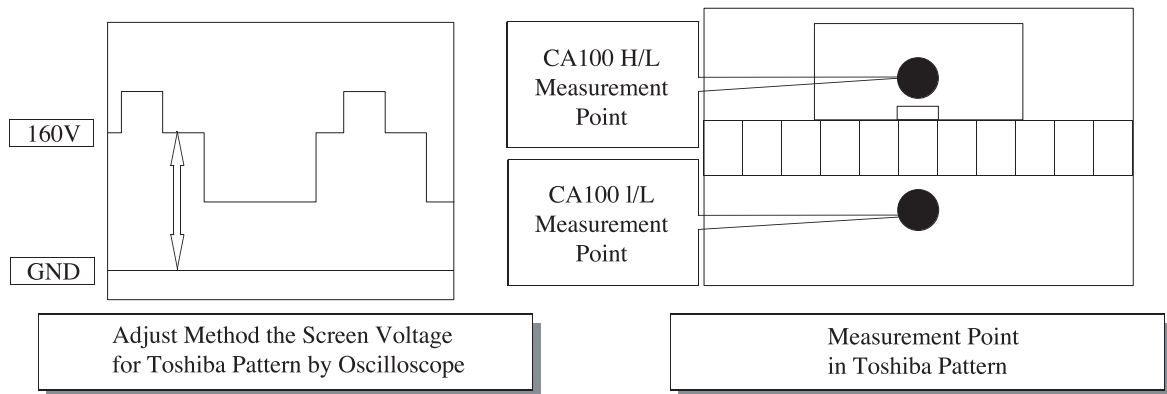

#### **4-1-5 When adjusting Screen Voltage and White Balance**

1. Screen Voltage and White Balance are related each other. Make sure both adjustments are correct.
2. Adjust Screen Voltage before White Balance Adjustments. Make sure Screen Voltage is correct.
3. If White Balance has been readjusted, re-check Screen Voltage.
4. After adjustments are complete, check the following.
  - If spots appear on the screen after pressing the Power On/Off key, readjust Screen Voltage.
  - If flyback lines appear on the screen, readjust Screen Voltage.

## 4-2 MICOM PORT

PIN	FUNCTION	FIRST STATE	ASSIGNMENT														
1	W-PORT	HIGH	RESET Control jack during E <sup>2</sup> PROM latch UP(Function:Low)SERIAL H														
2	ROM SDA	SERIAL H	E <sup>2</sup> PROM only SDA LINE														
3	ROM SCL	SERIAL H	E <sup>2</sup> PROM only SDA LINE														
4	BUS-STOP	HIGH	Automation and after-sales service related BUS STOP(STOP : LOW)														
5	MAIN SDA	SERIAL H	CXA2165 /CXA2151Q/VSP940X/BA7654F/MSP34XX/TUNER Control jack														
6	MAIN SCL	SERIAL H	CXA2165 /CXA2151Q/VSP940X/BA7654F/MSP34XX/TUNER Control jack														
7	S-RESET	HIGH	Reset when MSP34XX IC(SOUND PROCESS IC)has an error(Active : LOW)														
8	V-RESET	HIGH	Reset when VSP940X IC(1-chip IC)has an error														
9	VDD 2.5V	HIGH															
10	GND		Analog GND														
11	VDD3.3V	HIGH															
12	CVBS IN	IV p-p	TTX and USA Caption Input source line(1V p-p)														
13	VDD2.5V	HIGH															
14	GND																
15	AFT		Main AFT Control jack(0 ~ 3.3V)														
16	SC1-ID		<table border="1"> <thead> <tr> <th></th> <th>TV MODE</th> <th colspan="2">AV MODE</th> </tr> <tr> <th></th> <th></th> <th>16 : 9 MODE</th> <th>4 : 3 MODE</th> </tr> </thead> <tbody> <tr> <td>17</td> <td>SC2-ID</td> <td>RANGE</td> <td>0 ~ 2V</td> <td>4.5 ~ 7V</td> <td>9.5 ~ 12V</td> </tr> </tbody> </table>		TV MODE	AV MODE				16 : 9 MODE	4 : 3 MODE	17	SC2-ID	RANGE	0 ~ 2V	4.5 ~ 7V	9.5 ~ 12V
	TV MODE	AV MODE															
		16 : 9 MODE	4 : 3 MODE														
17	SC2-ID	RANGE	0 ~ 2V	4.5 ~ 7V	9.5 ~ 12V												
18	KEY-1	HIGH	<table border="1"> <thead> <tr> <th>16 : 9 MODE</th> <th>MEMU</th> <th>VOL-</th> <th>VOL+</th> <th>CH-</th> <th>CH+</th> </tr> </thead> <tbody> <tr> <td>0 ~ 2V</td> <td>0~0.1V</td> <td>0.1~0.7V</td> <td>07~13V</td> <td>1.3~1.9V</td> <td>0.9~2.4V</td> </tr> </tbody> </table>	16 : 9 MODE	MEMU	VOL-	VOL+	CH-	CH+	0 ~ 2V	0~0.1V	0.1~0.7V	07~13V	1.3~1.9V	0.9~2.4V		
16 : 9 MODE	MEMU	VOL-	VOL+	CH-	CH+												
0 ~ 2V	0~0.1V	0.1~0.7V	07~13V	1.3~1.9V	0.9~2.4V												
19	H-SYNC	POSITIVE	MICOM "H-SYNC" Input, POSITIVE Input(3.3V p-p)														
20	V-SYNC	POSITIVE	MICOM "V-SYNC" Input, POSITIVE Input(3.3V p-p)														
21	KEY-3	HIGH	OPEN														
22	KEY-2	HIGH	TV/VIDEO switching control jack														
23	X-RAY	HIGH	Function : LOW														
24	IR-IN		Remote Control Input Jack														
25	STD-LED	HIGH	STAND BY : Hight, OFF : LOW														
26	TIM-LED	LOW	TIME ON : H      TIME OFF : L														
27	RELAY		DEGAUSSIGN COIL CONTROL:Based on standard specifications														
28	SW1	HIGH	H : IN1, L : IN2(BA7657F) PIN(#16) Control jack														
29	GND																
30	VDD 3.3V	HIGH															
33	RESET	LOW															
34	X-IN		Reset active : HIGH														
35	X-OUT		Crystal oscillation input jack														

PIN	FUNCTION	FIRST STATE	ASSIGNMENT									
36	GND											
37	VDD 2.5V	HIGH										
38	OSD-R	1.2V p-p	OSD R-OUT Output jack (0.38V p-p), half tone : 0.9V p-p									
39	OSD-G	1.2V p-p	OSD G-OUT Output jack (0.38V p-p), half tone : 0.9V p-p									
40	OSD-B	1.2V p-p	OSD B-OUT Output jack (0.38V p-p), half tone : 0.9V p-p									
41	CPRE	0.9V p-p	OSD F/B-OUT Output jack (Clamped at STAND PULSE, Half Tone : LOW)									
42	VDD 2.5V	HIGH										
43	GND											
44	VDD 3.3V	HIGH										
45	PX, Y	HIGH										
46	PX, Y	HIGH										
47	SW3	H	<table border="1"> <thead> <tr> <th>F1</th> <th>F0</th> <th>fH</th> </tr> </thead> <tbody> <tr> <td>L</td> <td>M</td> <td>1.75KHz (480i/480P)</td> </tr> <tr> <td>M</td> <td>L</td> <td>33.75KHz (1080i)</td> </tr> </tbody> </table>	F1	F0	fH	L	M	1.75KHz (480i/480P)	M	L	33.75KHz (1080i)
F1	F0	fH										
L	M	1.75KHz (480i/480P)										
M	L	33.75KHz (1080i)										
48	SW2	L	<p>LOW : GNDHIGH : OPEN STATUS</p> <p>Initially, these pins select an input source at LOW state</p>									
49	S-MUTE		System (NTSC/PAL) MUST be separated									
50	POWER		Active "LOW"									
51	H,P-ID		1080i control jack : 1080i (LOW), RF (Hight)									
52	TILT	HIGH	Magnetic field control									

### 4-3 Factory Adjustment

#### 4-3-1 Factory Adjustment values

SERVICE
Deflection
480P Offset
1080i Offset
Video Adjust1
Video Adjust2
Video Adjust3
Option
YC Delay
EEPROM
Reset

#### 4-3-2 EUROPE & CIS Factory Data

##### DEFLECTION : PAL

	50	45	50	37	37	H/L : 285/285 29" CIS, EU W/B COORDINATE
	2.5	2	2.5	1.8	1.5	L/L : 285/285
ITEMS	29" CIS SDI CRT	32" CIS SDI CRT	34" CIS TOS CRT	29" EUR SDI CRT	32" EUR PHI CRT	REMARK
V-AMP	33	33	26	33	41	Vertical AMP adj(Gain Control)
V-SHIFT	28	28	24	28	26	Vertical Position adj(DC bias adj)
H-EW	26	32	17	26	36	Horizontal AMP adj(Gain Control)
H-SHIFT	0	0	26	0	21	Horizontal Position adj(DC bias adj)
V-LIN(Fix)	9	9	9	9	11	Vertical Linearity adj(Top/Bottom adj)
UP-LIN(Fix)	9	9	9	9	9	Vertical Linearity adj(Top adj)
LOW-LIN(Fix)	4	3	2	4	1	Vertical Linearity adj(Bottom adj)
V-SC(Fix)	3	1	3	3	0	Vertical S correction adj
H-PAR	38	38	51	38	19	Horizontal pin distortion adj
UP-COR	25	25	35	25	33	Horizontal pin distortion up adj
LOW-COR	31	31	36	31	33	Horizontal pin distortion low adj
H-TRA	18	18	42	18	43	Horizontal Tapezium distortion adj
BOW	33	33	31	33	33	Vertical line slope adj(parabola)
ANGLE	28	28	30	28	28	Vertical Linearity adj(sawtooth)
V-POSI(Fix)	35 -> 40	40	40	35 -> 40	40	V-Position adj as to CRT inch

**DEFLECTION : NTSC**

ITEMS	29" CIS SDI CRT	32" CIS SDI CRT	34" CIS TOS CRT	29" EUR SDI CRT	32" EUR PHI CRT	REMARK
V-AMP	-7	-7	-7	-7	0	Vertical AMP adj(Gain Control)
V-SHIFT	-4	-4	-4	-4	-1	Vertical Position adj(DC bias adj)
H-EW	5	5	5	5	1	Horizontal AMP adj(Gain Control)
H-SHIFT	30	30	30	30	3	Horizontal Position adj(DC bias adj)
V-LIN	-4	-4	-4	-4	-4	Vertical Linearity adj(Top/Bottom adj)
UP-LIN	-1	-1	-1	-1	-1	Vertical Linearity adj(Top adj)
LOW-LIN	3	3	3	3	3	Vertical Linearity adj(Bottom adj)
V-SC	0	0	0	0	0	Vertical S correction adj
H-PAR	8	8	8	8	1	Horizontal pin distortion adj
UP-COR	7	7	7	7	2	Horizontal pin distortion up adj
LOW-COR	3	3	3	3	-1	Horizontal pin distortion low adj
H-TRA	7	7	7	7	0	Horizontal Tapezium distortion adj
BOW	-1	-1	-1	-1	0	Vertical line slope adj(parabola)
ANGLE	-1	-1	-1	-1	0	Vertical Linearity adj(sawtooth)
V-POSI	0	0	0	0	0	V-Position adj as to CRT inch



 **Video Adjust 1**

ITEMS	29" CIS SDI CRT	32" CIS SDI CRT	34" CIS TOS CRT	29" EUR SDI CRT	32" EUR PHI CRT	REMARK
R-Cutoff	41	41	46	41	41	R-cutoff control adj
G-Cutoff(Fix)	25	25	32	32	32	G-cutoff control adj
B-Cutoff	28	28	18	28	38	B-cutoff control adj
Color on/off	1	1	1	1	1	initial : "0" -> 1
CR offset	32	32	32	32	32	DC-offset canceling adjust
CB offset	32	32	32	32	32	DC-offset canceling adjust
R-Drive	37	37	46	37	40	R-Drive control adj
G-Drive(Fix)	32	32	32	32	32	G-Drive control adj
B-Drive	32	32	26	32	38	B-Drive control adj
Sub-Bright	32	32	40	32	47	Sub-Bright control
Sub-Contrast	7	7	7	7	7	Sub-Contrast control
Sub-Color(Fix)	15	15	10	15	15	color gain control(PAL SETTING AGAIN)
Sub-TInt(Fix)	28	28	28	28	28	HUE control
CTI-Level(Fix)	1	1	1	1	1	Chrominance Transient Improvement
COL AXIS(Fix)	1	1	1	1	1	color detection axis setting(NTSC/USA)
LTI-Level(Fix)	1	1	1	1	1	Luminance Transient Improvement
VSU(Fix)	2	2	2	2	2	vertical osd position
Merody Volume(Fix)	7	7	7	7	7	Volume gain control

**Video Adjust 2**

ITEMS	29" CIS SDI CRT	32" CIS SDI CRT	34" CIS TOS CRT	29" EUR SDI CRT	32" EUR PHI CRT	REMARK
ABL Mode	3	3	3	3	3	Rpicture/bright ABL gain control
Gamma	2	2	2	2	2	RGB output correction control
DPIC Level	3	3	3	3	3	Dynamic picture black expansion control
DC Trans	3	3	3	3	3	Y-System DC transmission ratio
ABL-TH	14	15	14	14	14	Threshold voltage adj ABL-IN
VM-Level	1	1	1	1	1	VM-OUT Level control
VM-Coring	2	2	2	2	2	VM-OUT coring control
VM-f0	2	2	2	2	2	VM-f0 control
VM-Limit	2	2	2	2	2	VM-Limit level control
VM-Delay	3	3	3	3	3	VM-OUT phase control(reference to R-OUT)
SHP CD	1	1	1	1	1	Sharpness gain control(color saturation)
SHP f0	0	0	0	0	0	Sharpness f0 control (3Mhz)
SHP f1&p/o	8	8	8	8	8	Sharpness gain control(PAL SETTING AGAIN)
AKB Time	13	13	13	13	13	AKB Bch reference pulse time control
Bandpass	17h	17h	17h	17h	17h	VSP9407B Band pass filter
Highpass	23h	23h	23h	23h	23h	VSP9407B High pass filter

**Video Adjust 3**

ITEMS	29" CIS SDI CRT	32" CIS SDI CRT	34" CIS TOS CRT	29" EUR SDI CRT	32" EUR PHI CRT	REMARK
H comp	7	8	4	7	6	H-EHT compensation setting(PAL SETTING AGAIN)
V comp	4	5	4	4	4	V-EHT compensation setting(PAL SETTING AGAIN)
PIN comp	2	2	7	7	2	PIN-EHT compensation setting(PAL SETTING AGAIN)
AFC comp	0	0	0	0	0	AFC-EHT compensation
sync phase	0	0	0	0	0	WHEN USED 74HC123
NR Value	6	6	6	6	6	PAL SETTING AGAIN

 **Option Byte(CIS Model)**

ITEMS	29" CIS SDI CRT	32" CIS SDI CRT	34" CIS TOS CRT	29" EUR SDI CRT	32" EUR PHI CRT	REMARK
Language	CIS	CIS	CIS	NON	NON	CIS/ARAB
SOUND	V-DOLBY	V-DOLBY	V-DOLBY	V-DOLBY	V-DOLBY	V-DOLBY/A2-NICAM
CRT	4:3	WIDE	4:3	WIDE	WIDE	
AV JACK	SCART	SCART	SCART	SCART	SCART	SCART(CIS,EUROPE)/RCA(ASIA,AUSTRALIA)
AUTO FM	ON	ON	ON	ON	ON	ON/OFF
PIP	ON	ON	ON	ON	ON	ON/OFF(W/O PIP MODEL)
TXT LANGUAGE	ON	ON	ON	WESTERN EUROPE	WESTERN EUROPE	OPTION
LNA	ON	ON	OFF	ON	ON	ON/OFF(1 TUNER)
HIGH DEVIATION	OFF	OFF	OFF	OFF	OFF	OFF/ON(INDIA)
AV BY CH KEY	OFF	OFF	OFF	OFF	OFF	OFF/ON
DTV	OFF	OFF	OFF	OFF	OFF	OFF/ON
VGA	OFF	OFF	OFF	OFF	OFF	OFF/OFF
AGC	OFF	OFF	OFF	OFF	OFF	OFF/ON
WOOFER	OFF	OFF	NON	OFF	OFF	OFF/ON
SPEAKER	NON	NON	NON	DOME SPK	DOME SPK	EQ CURVE(DOME/NON DOME SPK)
TTX TOP	NON	NON	NON	OFF	OFF	OFF/ON
HELP	NON	NON	NON	OFF	OFF	OFF/ON
TTX ON/OFF	NON	NON	NON	ON	ON	OFF/ON
TTX LIST PRIORITY	NON	NON	NON	NON	NON	OFF/ON

**YC Delay**

ITEMS	29" CIS SDI CRT	32" CIS SDI CRT	34" CIS TOS CRT	29" EUR SDI CRT	32" EUR PHI CRT	REMARK
P.YC(AV) DELAY	1	1	1	2	2	
S.YC(AV) DELAY	-5	-5	-5	-5	-5	
N.YC(AV) DELAY	2	2	2	4	4	
P.BG.YC DELAY	0	0	0	4	4	
P.DK.YC DELAY	-2	-2	-2	2	2	
P.I.YC DELAY	-1	-1	-1	1	1	
P.M.YC DELAY	0	0	0	0	0	
P.L.YC DELAY	0	0	0	0	0	
S.BG.YC DELAY	-6	-6	-6	-2	-2	
S.DK.YC DELAY	-9	-9	-9	-7	-7	
S.I.YC DELAY	-9	-9	-9	-9	-9	
S.L.YC DELAY	0	0	0	-5	-5	
N.M.YC DELAY	0	0	0	0	0	

 **EUROPE & CIS EEPROM Data**

F-No	Factory Control Name	Range	29" CIS SDI CRT	32" CIS SDI CRT	34" CIS TOS CRT	29" EUR SDI CRT	32" EUR PHI CRT	REMARK
0	UP-UCG(up corner semi control)	0~3	1	0	0	0	0	
1	LO-UCG(low corner semi control)	0~3	1	0	0	0	0	
2	LTI Mode	0~3	2	2	2	1	1	
3	System	0~3	1	1	1	2	2	
4	50 Hz Progressive Trapezium	0~255	6	5	13	6	5	
5	60 Hz Progressive Trapezium	0~255	7	7	11	7	7	
6	Dynamic Contrast	0~100	70	70	100	70	100	
7	Dynamic Brightness	0~100	40	40	40	50	50	
8	Dynamic Sharpness	0~100	60	60	60	40	40	
9	Dynamic Color	0~100	60	70	60	60	60	
10	Dynamic ColorTone	0~100	50	50	50	50	50	
11	Dynamic Tint	0~100	50	50	50	50	50	
12	Standard Contrast	0~100	40	50	60	50	80	
13	Standard Brightness	0~100	40	40	42	45	50	
14	Standard Sharpness	0~100	50	50	50	40	40	
15	Standard Color	0~100	50	60	50	50	50	
16	Standard ColorTone	0~100	50	50	50	50	50	
17	Standard Tint	0~100	50	50	50	50	50	
18	Movie Contrast	0~100	30	35	40	40	60	
19	Movie Brightness	0~100	40	40	40	45	50	
20	Movie Sharpness	0~100	50	50	50	40	40	
21	Movie Color	0~100	45	55	45	45	45	
22	Movie ColorTone	0~100	50	50	50	50	50	
23	Movie Tint	0~100	50	50	50	50	50	
24	PROGRESSIVE TTX V-POSITION	0~255	76	78	76	76	76	
25	PROGRESSIVE TTX H-POSITION	0~255	186	187	184	186	190	
26		0~100	255	255	255	255	255	
27		0~100	255	255	255	255	255	
28		0~100	255	255	255	255	255	
29		0~100	255	255	255	255	255	
30	Brightness(RGB/DVD)	0~255	0	0	0	0	0	
31	Contrast(RGB/DVD)	0~255	124	124	124	124	124	
32	U Saturation(RGB/DVD)	0~255	125	125	125	125	125	

F-No	Factory Control Name	Range	29" CIS SDI CRT	32" CIS SDI CRT	34" CIS TOS CRT	29" EUR SDI CRT	32" EUR PHI CRT	REMARK
33	V saturation(RGB/DVD)	0~255	248	248	248	248	248	
34	9407 Y Gain	0~255	93	93	93	80	80	
35	9407 U Gain	0~255	83	83	83	71	71	
36	Luminance Delay(Fixed Value)	0~255	8	8	8	8	8	
37	9407 V Gain	0~255	82	82	82	70	70	
38	Start Value of Lum LUT(Main)-NR_ON	0~255	255	255	255	255	255	
39	Noise Reduction(Main)-NR_ON	0~255	102	102	102	102	102	
40	Start Value of Lum LUT(PIP)-NR_ON	0~255	255	255	255	255	255	
41	Noise Reduction(PIP)-NR_ON	0~255	102	102	102	102	102	
42	Vertical End of Clamping Pulse	0~255	28	28	28	28	28	
43	SECAM Color Sensitivity(Main)	0~255	28	28	28	28	28	
44	Vertical End of Clamping Pulse	0~255	28	28	28	28	28	
45	SECAM Color Sensitivity(PIP)	0~255	28	28	28	28	28	
46	Left Blanking	0~255	147	147	147	147	147	
47	Right Blanking	0~255	153	153	153	153	153	
48	S-ABL	0~255	0	0	0	0	0	
49	P-ABL	0~255	48	64	48	48	48	
50	Start Value of Lum LUT(Main)-NR_OFF	0~255	255	255	255	255	255	
51	Noise Reduction(Main)-NR_OFF	0~255	255	255	255	255	255	
52	Start Value of Lum LUT(PIP)-NR_OFF	0~255	255	255	255	255	255	
53	Noise Reduction(PIP)-NR_OFF	0~255	255	255	255	255	255	
54	Picture Limit Level	0~3	3	3	3	3	3	
55	OSD LEVEL(LRGB2_LEV)	0~15	7	7	10	7	7	
56	TTX LEVEL(LRGB2_LEV)	0~15	0	0	0	5	5	
57	Left Blanking (480p)	0~255	0	0	0	0	0	
58	Right Blanking (480p)	0~255	0	0	0	0	0	
59	Left Blanking (1080i)	0~255	0	0	0	0	0	
60	Right Blanking (1080i)	0~255	0	0	0	0	0	
61	System (480p)	0~3	0	0	0	0	0	
62	System (1080i)	0~3	0	0	0	0	0	
63	CrCb Gain (480p)	0~255	0	0	0	0	0	
64	CrCb Gain (1080i)	0~255	0	0	0	0	0	
65	LTI Mode (480p)	0~3	0	0	0	0	0	

Alignment and Adjustments

F-No	Factory Control Name	Range	29" CIS SDI CRT	32" CIS SDI CRT	34" CIS TOS CRT	29" EUR SDI CRT	32" EUR PHI CRT	REMARK
66	LTI Mode (1080i)	0~3	0	0	0	0	0	
67	TTX V Position	0~255	37	37	37	37	38	
68	TTX H Position	0~255	186	188	185	186	190	
69	16 PIP UPPER CORNER OFF SET	0~255	2	4	3	2	4	
70	16 PIP LOWER CORNER OFF SET	0~255	1	0	3	1	0	
71	4:3 Normal Parabola	0~255	0	0	0	0	0	

### 4-3-3 AISA Factory Data

#### DEFLECTION : PAL

ITEMS	29" AISA SDI CRT	32" Australia LG CRT	29" Australia SDI CRT	REMARK
V-AMP	35	24	39	Vertical AMP adj(Gain Control)
V-SHIFT	22	27	27	Vertical Position adj(DC bias adj)
H- EW	40	34	31	Horizontal AMP adj(Gain Control)
H-SHIFT	22	21	17	Horizontal Position adj(DC bias adj)
V-LIN	7	9	9	Vertical Linearity adj(Top/Bottom adj)
UP-LIN	9	9	9	Vertical Linearity adj(Top adj)
LOW-LIN	4	3	4	Vertical Linearity adj(Bottom adj)
V-SC	1	1	3	Vertical S correction adj
H-PAR	33	20	39	Horizontal pin distortion adj
UP-COR	18	32	31	Horizontal pin distortion up adj
LOW-COR	27	35	32	Horizontal pin distortion low adj
H-TRA	24	32	36	Horizontal Tapezium distortion adj
BOW	33	32	35	Vertical line slope adj(parabola)
ANGLE	31	30	26	Vertical Linearity adj(sawtooth)
V-POSI	40	40	40	V-Position adj as to CRT inch



 **DEFLECTION : NTSC**

ITEMS	29" AISA SDI CRT	32" Australia LG CRT	29" Australia SDI CRT	REMARK
V-AMP	1	2	1	Vertical AMP adj( Gain Control)
V-SHIFT	0	-2	-2	Vertical Position adj (DC bias adj)
H- EW	-2	0	-1	Horizontal AMP adj(Gain Control)
H-SHIFT	10	8	9	Horizontal Position adj (DC bias adj)
V-LIN	-4	-4	-4	Vertical Linearity adj(TOP/Bottom adj)
UP-LIN	-1	-1	-1	Vertical Linearity adj(TOP adj)
LOW-LIN	2	3	2	Vertical Linearity adj(Bottom adj)
V-SC	0	0	0	Vertical S correction adj
H-PAR	1	0	2	Horizontal pin distortion adj
UP-COR	4	1	2	Horizontal pin distortion up adj
LOW-COR	-3	-3	-3	Horizontal pin distortion low adj
H-TRA	4	0	4	Horizontal Trapezium distortion adj
BOW	0	0	1	Vertical line slope adj(parabola)
ANGLE	0	0	-1	Vertical Linearity adj(sawtooth)
V-POSI	0	0	0	V-POSITION ADJ as to CRT INCH

 **480p Offset**

ITEMS	29" AISA SDI CRT	32" Australia LG CRT	29" Australia SDI CRT	REMARK
V-AMP	-1	2	-8	Vertical AMP adj( Gain Control)
V-SHIFT	1	-3	2	Vertical Position adj (DC bias adj)
H- EW	8	4	3	Horizontal AMP adj(Gain Control)
H-SHIFT	-9	-7	-9	Horizontal Position adj (DC bias adj)
V-LIN	0	-4	0	Vertical Linearity adj(TOP/Bottom adj)
UP-LIN	0	-1	-1	Vertical Linearity adj(TOP adj)
LOW-LIN	0	3	-3	Vertical Linearity adj(Bottom adj)
V-SC	0	0	2	Vertical S correction adj
H-PAR	0	-4	1	Horizontal pin distortion adj
UP-COR	0	3	-1	Horizontal pin distortion up adj
LOW-COR	0	-3	-1	Horizontal pin distortion low adj
H-TRA	-7	4	3	Horizontal Trapezium distortion adj
BOW	0	0	2	Vertical line slope adj(parabola)
ANGLE	0	1	0	Vertical Linearity adj(sawtooth)
V-POSI	0	0	0	V-POSITION ADJ as to CRT INCH

**1080i Offset**

ITEMS	29" AISA SDI CRT	32" Australia LG CRT	29" Australia SDI CRT	REMARK
V-AMP	-14	-1	-4	Vertical AMP adj( Gain Control)
V-SHIFT	2	-2	-1	Vertical Position adj (DC bias adj)
H- EW	6	-10	2	Horizontal AMP adj(Gain Control)
H-SHIFT	4	11	10	Horizontal Position adj (DC bias adj)
V-LIN	0	0	-1	Vertical Linearity adj(TOP/Bottom adj)
UP-LIN	0	0	0	Vertical Linearity adj(TOP adj)
LOW-LIN	0	0	-1	Vertical Linearity adj(Bottom adj)
V-SC	0	0	0	Vertical S correction adj
H-PAR	0	3	-1	Horizontal pin distortion adj
UP-COR	0	5	0	Horizontal pin distortion up adj
LOW-COR	0	3	1	Horizontal pin distortion low adj
H-TRA	0	2	-3	Horizontal Trapezium distortion adj
BOW	0	-1	1	Vertical line slope adj(parabola)
ANGLE	0	1	2	Vertical Linearity adj(sawtooth)
V-POSI	0	0	0	V-POSITION ADJ as to CRT INCH

 **Video Adjust 1**

ITEMS	29" AISA SDI CRT	32" Australia LG CRT	29" Australia SDI CRT	REMARK
R-Cutoff	41	31	41	R-cutoff control adj
G-Cutoff	32	32	32	G-cutoff control adj
B-Cutoff	28	43	28	B-cutoff control adj
Color on/off	1	1	1	Fixed : "0"--> 1
CR offset	32	32	32	DC-offset canceling adjust
CB offset	32	32	32	DC-offset canceling adjust
R-Drive	37	37	37	R-Drive control adj
G-Drive	32	32	32	G-Drive control adj
B-Drive	32	43	32	B-Drive control adj
Sub-Bright	32	33	32	Sub-Bright control
Sub-Contrast	7	7	7	Sub-Contrast control
Sub-Color	15	15	15	color gain control(PAL SETTING AGAIN)
Sub-Tint	28	28	28	HUE control
CTI-Level	1	1	1	Chrominance Transient Improvement
COL AXIS	1	1	1	color detection axis setting(NTSC/USA)
LTI-Level	1	1	1	Luminance Transient Improvement
VSU	2	2	2	vertical osd position
Merody Volume	4	4	4	Volume gain control

**Video Adjust 2**

ITEMS	29" AISA SDI CRT	32" Australia LG CRT	29" Australia SDI CRT	REMARK
ABL Mode	3	3	3	picture/bright ABL gain control
Gamma	2	2	2	RGB output correction control
DPIC Level	3	3	3	Dynamic picture black expansion control
DC Trans	3	3	3	Y-System DC transmission ratio
ABL-TH	14	15	14	Threshold voltage adj ABL-IN
VM-Level	1	1	1	VM-OUT Level control
VM-Coring	2	2	2	VM-OUT coring control
VM-f0	2	2	2	VM-f0 control
VM-Limit	2	2	2	VM-Limit level control
VM-Delay	3	3	3	VM-OUT phase control(reference to R-OUT)
SHP CD	1	1	1	Sharpness gain control(color saturation)
SHP f0	0	0	0	Sharpness f0 control (3Mhz)
SHP f1&p/o	8	8	8	Sharpness gain control(PAL SETTING AGAIN)
AKB Time	13	13	13	AKB Bch reference pulse time control
Bandpass	17	17	17	VSP9407B Band pass filter
Highpass	23	23	23	VSP9407B High pass filter

**Video Adjust 3**

ITEMS	29" AISA SDI CRT	32" Australia LG CRT	29" Australia SDI CRT	REMARK
H comp	7	6	7	H-EHT compensation setting(PAL SETTING AGAIN)
V comp	4	4	4	V-EHT compensation setting(PAL SETTING AGAIN)
PIN comp	2	2	2	PIN-EHT compensation setting(PAL SETTING AGAIN)
AFC comp	0	0	0	AFC-EHT compensation
sync phase	0	0	0	WHEN USED 74HC123
NR Value	6	6	6	PAL SETTING AGAIN
sync phase(480p)	1	1	1	WHEN USED 74HC123
sync phase(1080i)	0	0	0	WHEN USED 74HC123

 **DTV Adjust (480p/1080i)**

ITEMS	29" AISA SDI CRT	32" Australia LG CRT	29" Australia SDI CRT	REMARK
Sub-Bright	19	38	19	
Sub-Contrast	7	7	7	
Sub-Color	15	15	15	
Sub-Tint	28	28	28	
COL AXIS	1	1	1	
LTI-Level	2	2	1	
VM-Level	1	1	1	
VM-Coring	2	2	2	
VM-f0	2	2	2	
VM-Limit	2	2	2	
VM-Delay	3	3	3	
SHP CD	1	1	1	
SHP f0	0	0	0	
SHP f1 & p/o	8	8	8	

 **Option Byte(ASIA Model)**

ITEMS	29" AISA SDI CRT	32" Australia LG CRT	29" Australia SDI CRT	REMARK
Language	Asia	ASIA	ASIA	CIS/ARAB
SOUND	V-DOLBY	V-DOLBY	V-DOLBY	V-DOLBY/A2-NICAM
CRT	4:3	WIDE	4:3	
AV JACK	RCA	RCA	RCA	SCART(CIS,EUROPE)/RCA(ASIA,AUSTRALIA)
AUTO FM	ON	ON	ON	ON/OFF
PIP	ON	ON	ON	ON/OFF(W/O PIP MODEL)
TXT LANGUAGE	ON	ON	ON	RUSSIA/GREEK-TURKEY/ARABIC/FARSI/ ARAB-HEBREW/WEST EUROPE/EAST EUROPE
LNA	ON	ON	ON	ON/OFF(1 TUNER)
HIGH DEVIATION	OFF	OFF	OFF	OFF/ON(INDIA)
AV BY CH KEY	OFF	OFF	OFF	OFF/ON
DTV	ON	ON	ON	OFF/ON
VGA	OFF	OFF	OFF	OFF/OFF
AGC	OFF	OFF	OFF	OFF/ON
WOOFER	OFF	OFF	OFF	OFF/ON (Z7PART : ON, OTHERS : OFF)

**YC Delay**

ITEMS	29" AISA SDI CRT	32" Australia LG CRT	29" Australia SDI CRT	REMARK
P.YC(AV) DELAY	1	1	1	
S.YC(AV) DELAY	-5	-5	-5	
N.YC(AV) DELAY	2	2	2	
P.BG.YC DELAY	0	0	0	
P.DK.YC DELAY	-2	-2	-2	
P.I.YC DELAY	-1	-1	-1	
P.M.YC DELAY	0	0	0	
P.L.YC DELAY	0	0	0	
S.BG.YC DELAY	-6	-6	-6	
S.DK.YC DELAY	-9	-9	-9	
S.I.YC DELAY	-9	-9	-9	
S.M.YC DELAY	0	0	0	
S.L.YC DELAY	0	0	0	
N.M.YC DELAY	0	0	0	

High Voltage(kV)		30.64kV	31.62kV	Lion-head(Dynamic mode)
		33.8kV	33.97kV	
Beam Current(mA)		1.833mA	1.82mA	

**ASIA EEPROM Data**

F-No	Factory Control Name	Range	29" AISA SDI CRT	32" Australia LG CRT	29" Australia SDI CRT	REMARK
0	UP-UCG(up corner semi control)	0~3	1	0	1	
1	LO-UCG(low corner semi control)	0~3	1	0	1	
2	LTI Mode	0~3	2	2	2	
3	System	0~3	1	1	1	
4	50 Hz Progressive Trapezium	0~63	6	7	6	
5	60 Hz Progressive Trapezium	0~63	7	7	7	
6	Dynamic Contrast	0~100	90	100	90	
7	Dynamic Brightness	0~100	50	50	50	
8	Dynamic Sharpness	0~100	50	50	50	
9	Dynamic Color	0~100	60	60	60	
10	Dynamic ColorTone	0~100	50	50	50	
11	Dynamic Tint	0~100	50	50	50	
12	Standard Contrast	0~100	70	80	70	
13	Standard Brightness	0~100	50	50	50	
14	Standard Sharpness	0~100	50	40	50	
15	Standard Color	0~100	50	50	50	
16	Standard ColorTone	0~100	50	50	50	
17	Standard Tint	0~100	50	50	50	
18	Movie Contrast	0~100	50	60	50	
19	Movie Brightness	0~100	50	50	50	
20	Movie Sharpness	0~100	50	40	50	
21	Movie Color	0~100	45	50	45	
22	Movie ColorTone	0~100	50	50	50	
23	Movie Tint	0~100	50	50	50	
24	PROGRESSIVE TTX V-POSITION	0~255	76	78	76	
25	PROGRESSIVE TTX H-POSITION	0~255	186	187	186	
26	1080i 50Hz OSD V-POSITION	0~255	32	32	32	
27	1080i 50Hz OSD H-POSITION	0~255	255	255	255	
28	1080i 60Hz OSD V-POSITION	0~255	32	32	32	
29	1080i 60Hz OSD H-POSITION	0~255	184	184	184	
30	Brightness(RGB/DVD)	0~255	0	0	0	
31	Contrast(RGB/DVD)	0~255	124	124	124	
32	U Saturation(RGB/DVD)	0~255	125	125	125	

F-No	Factory Control Name	Range	29" AISA SDI CRT	32" Australia LG CRT	29" Australia SDI CRT	REMARK
33	V saturation(RGB/DVD)	0~255	248	248	248	
34	9407 Y Gain	0~255	93	93	93	
35	9407 U Gain	0~255	83	83	83	
36	Luminance Delay(FIX)	0~255	8	8	8	
37	9407 V Gain	0~255	82	82	82	
38	Start Value of Lum LUT(Main)-NR_ON	0~255	255	255	255	
39	Noise Reduction(Main)-NR_ON	0~255	102	102	102	
40	Start Value of Lum LUT(PIP)-NR_ON	0~255	255	255	255	
41	Noise Reduction(PIP)-NR_ON	0~255	102	102	102	
42	Vertical End of Clamping Pulse	0~255	28	28	28	
43	SECAM Color Sensitivity(Main)	0~255	28	28	28	
44	Vertical End of Clamping Pulse	0~255	28	28	28	
45	SECAM Color Sensitivity(PIP)	0~255	28	28	28	
46	Left Blanking	0~255	147	147	147	
47	Right Blanking	0~255	153	153	153	
48	S-ABL	0~255	0	0	0	
49	P-ABL	0~255	48	48	48	
50	Start Value of Lum LUT(Main)-NR_OFF	0~255	255	255	255	
51	Noise Reduction(Main)-NR_OFF	0~255	255	255	255	
52	Start Value of Lum LUT(PIP)-NR_OFF	0~255	255	255	255	
53	Noise Reduction(PIP)-NR_OFF	0~255	255	255	255	
54	Picture Limit Level	0~3	3	3	3	
55	OSD LEVEL(LRGB2_LEV)	0~15	12	12	12	
56	TTX LEVEL(LRGB2_LEV)	0~15	5	5	5	
57	Left Blanking (480p)	0~255	195	195	195	
58	Right Blanking (480p)	0~255	165	165	165	
59	Left Blanking (1080i)	0~255	167	167	167	
60	Right Blanking (1080i)	0~255	125	125	125	
61	System (480p)	0~3	1	1	1	
62	System (1080i)	0~3	1	1	1	
63	CrCb Gain (480p)	0~255	119	119	119	
64	CrCb Gain (1080i)	0~255	119	119	119	
65	LTI Mode (480p)	0~3	1	1	1	



Alignment and Adjustments

F-No	Factory Control Name	Range	29" AISA SDI CRT	32" Australia LG CRT	29" Australia SDI CRT	REMARK
66	LTI Mode (1080i)	0~3	1	1	1	
67	TTX V Position	0~255	38	38	38	
68	TTX H Position	0~255	186	188	186	
69	16PIP UPPER CORNER OFF SET	0~255	4	0	4	
70	16 PIP LOWER CORNER OFF SET	0~255	1	0	1	
71	4:3 Normal Parabola	0~255	0	0	0	

### 4-4 Screen Change(I<sup>2</sup>C Bus Geometric Adjustment)

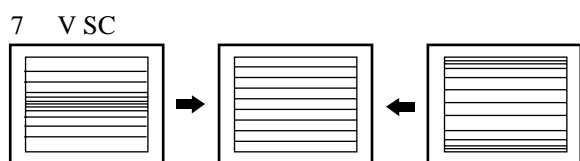
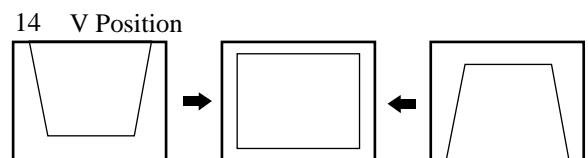
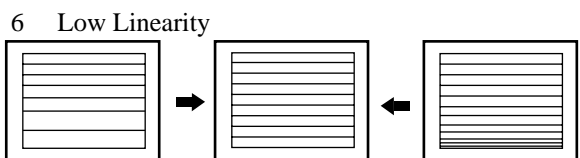
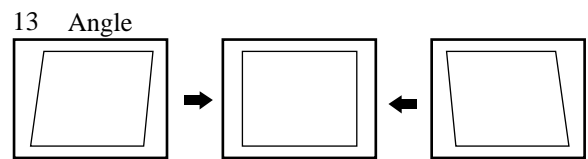
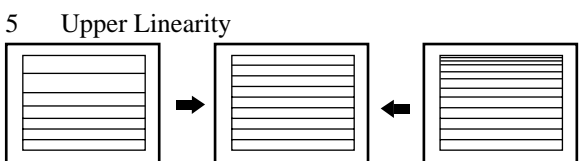
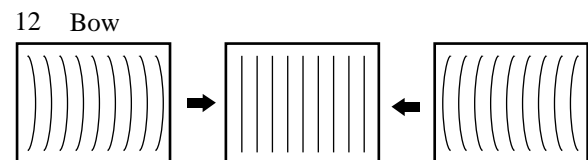
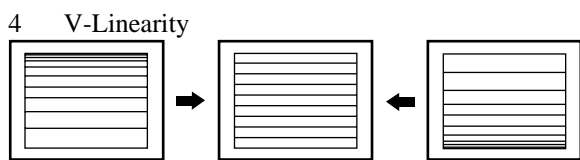
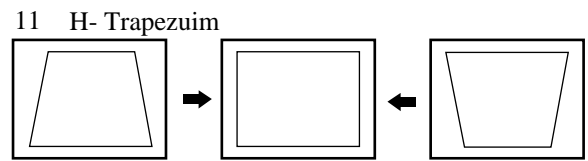
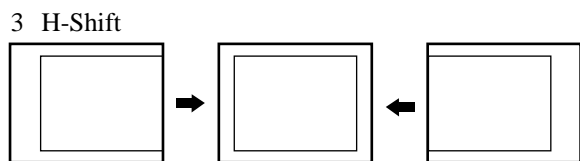
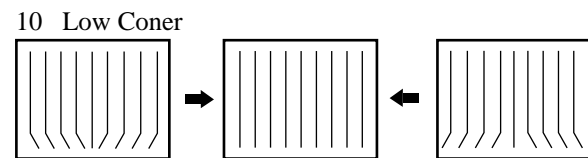
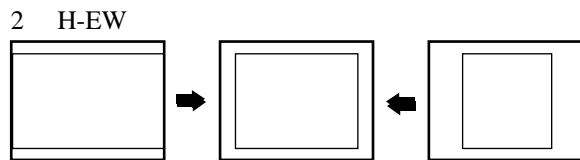
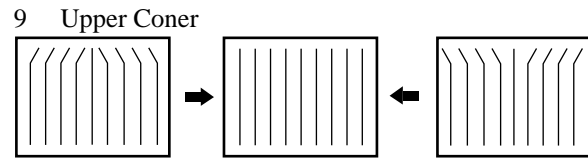
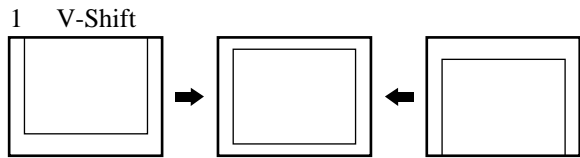
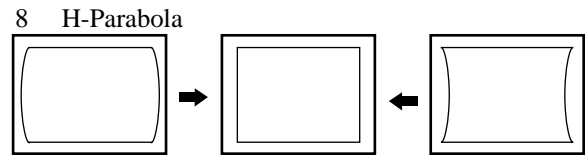
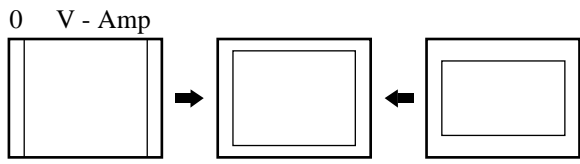

## 5. Troubleshooting

### 5-1 No Raster

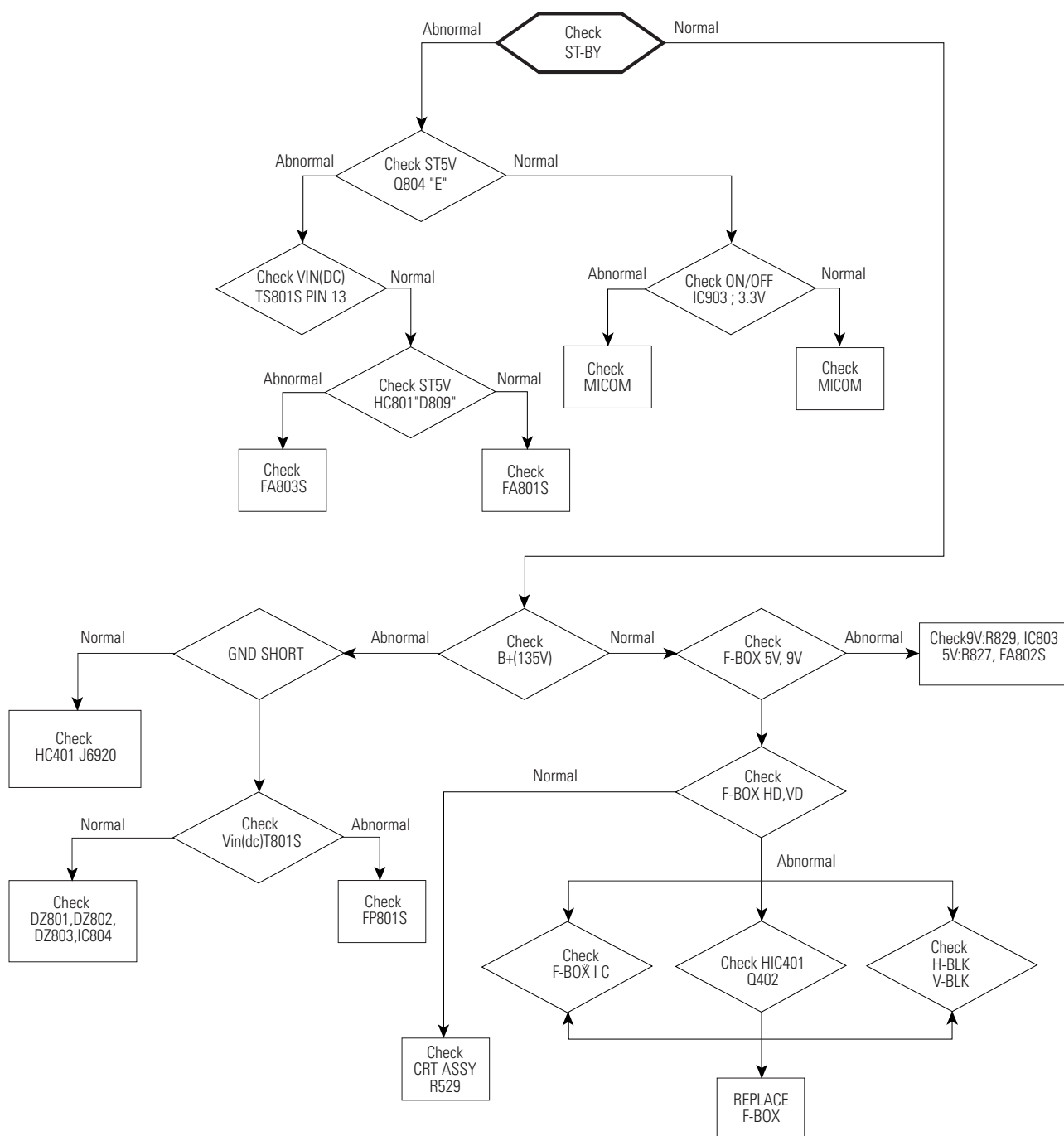

## 5-2 No Sound

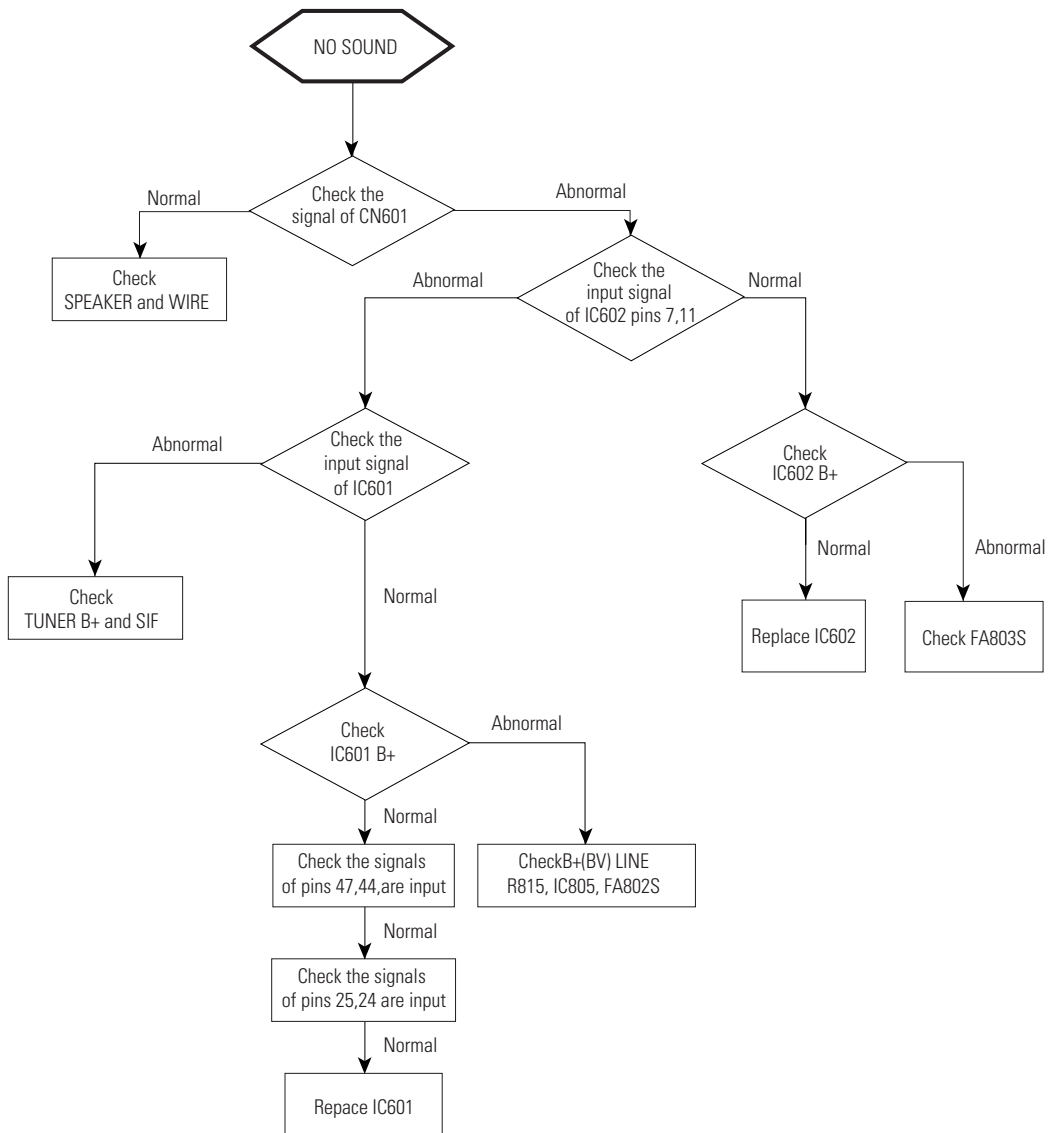

## 5-3 No Power

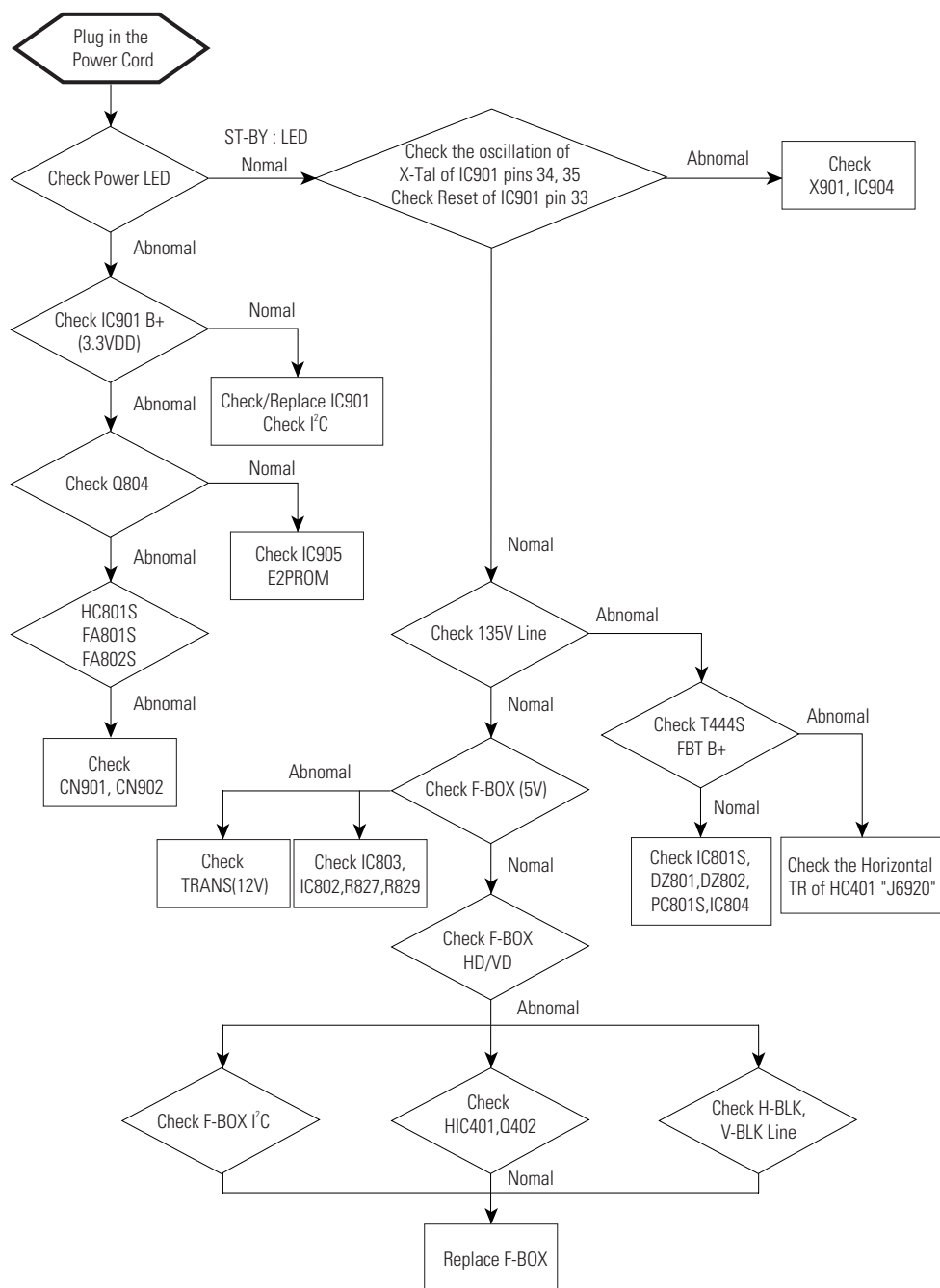

## 5-4 Horizontal Lines Appear

---

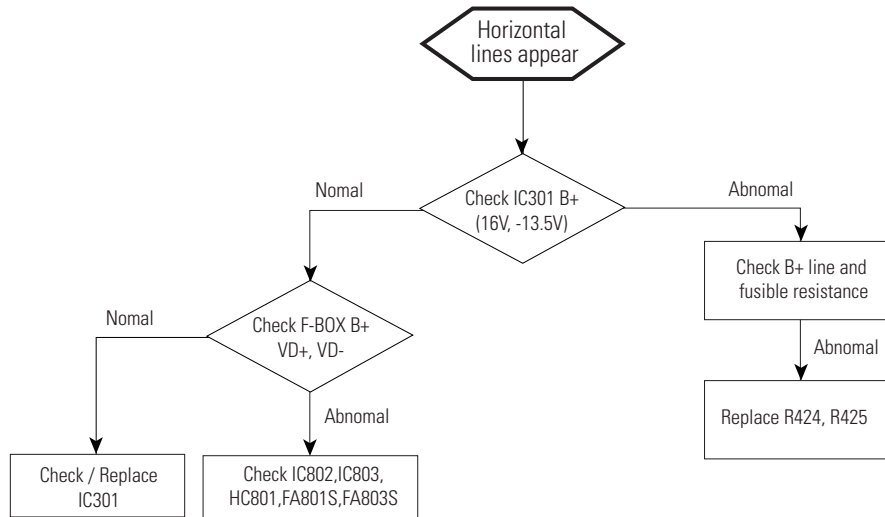

# 9. Schematic Diagrams

## 9-1 MAIN 1

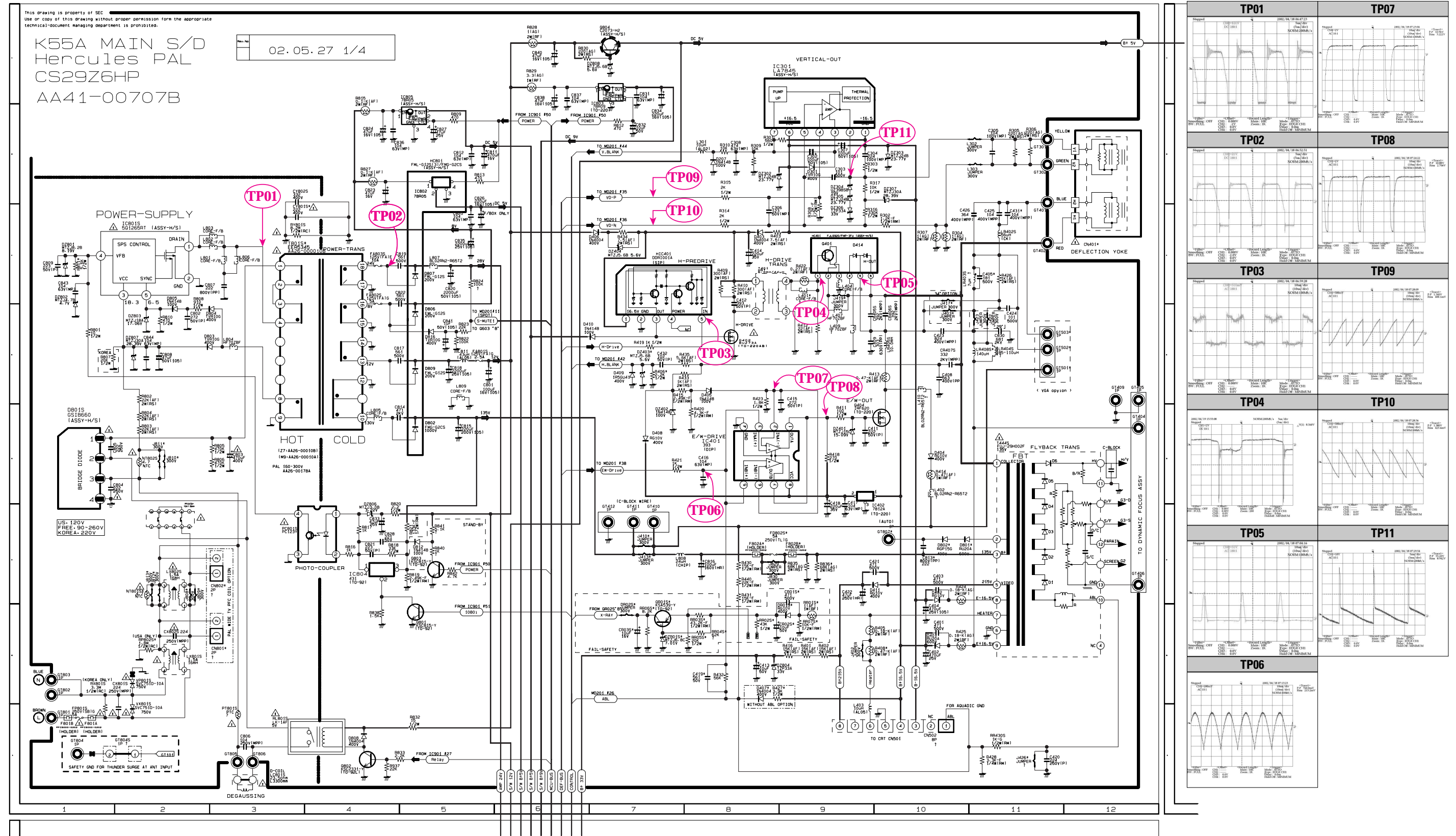

9-2 MAIN 2

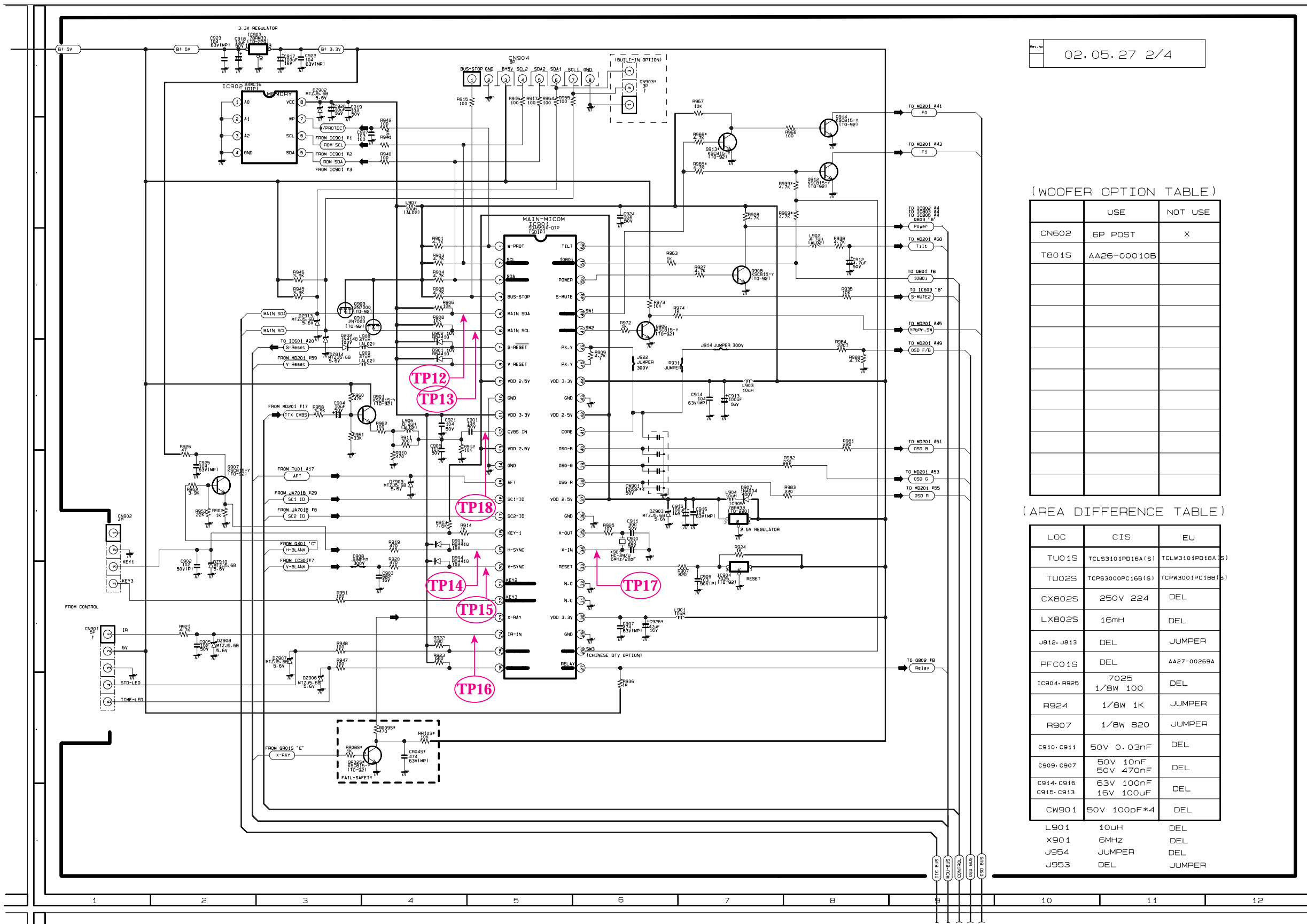

(WOOFER OPTION TABLE)

	USE	NOT USE
CN602	6P POST	X
T801S	AA26-00010B	

(AREA DIFFERENCE TABLE)

LOC	CIS	EU
TU01S	TCL9310PD16A(S)	TCLW310PD18A(S)
TU02S	TCPS3000PC16B(S)	TCPW3001PC18B(S)
CX802S	250V 224	DEL
LX802S	16mH	DEL
J812, J813	DEL	JUMPER
PFC01S	DEL	AA27-00269A
IC904, R925	7025 1/8W 100	DEL
R924	1/8W 1K	JUMPER
R907	1/8W 820	JUMPER
C910, C911	50V 0.03nF	DEL
C909, C907	50V 10nF 50V 470nF	DEL
C914, C913	63V 100nF	DEL
C915, C913	16V 100uF	DEL
CW901	50V 100pF *4	DEL
L901	10uH	DEL
X901	6MHZ	DEL
J954	JUMPER	DEL
J953	DEL	JUMPER

**TP12**

**TP13**

**TP14**

**TP15**

**TP16**

**TP17**

**TP18**



9-3 MAIN 3

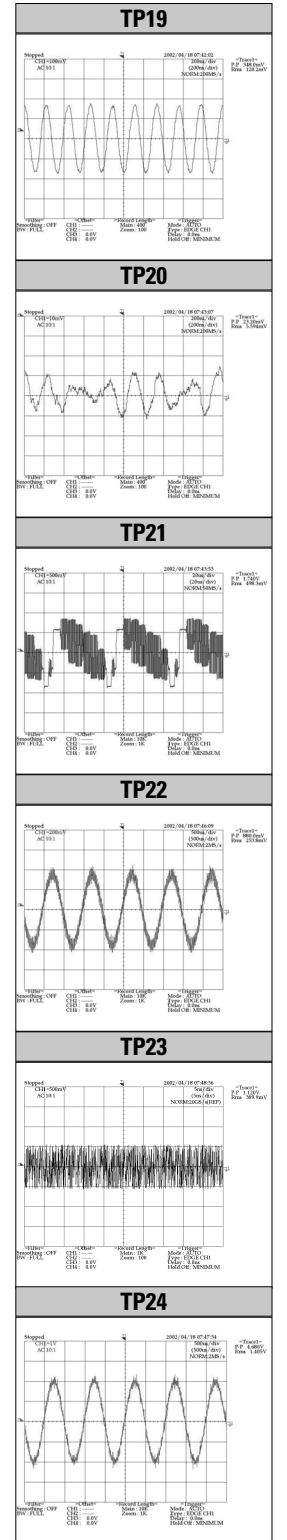
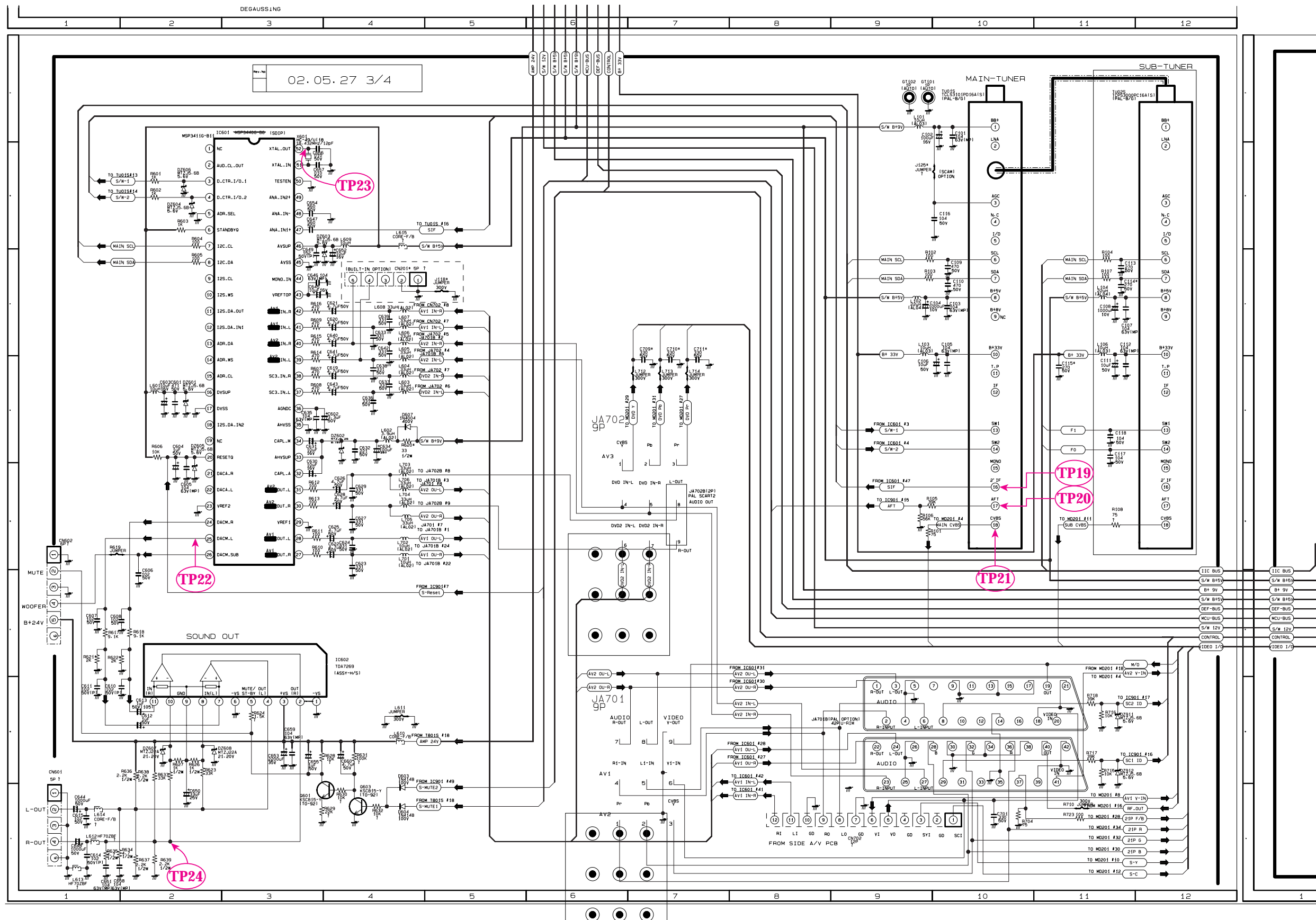

9-4 MAIN 4

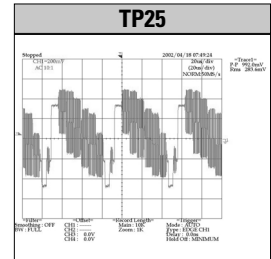
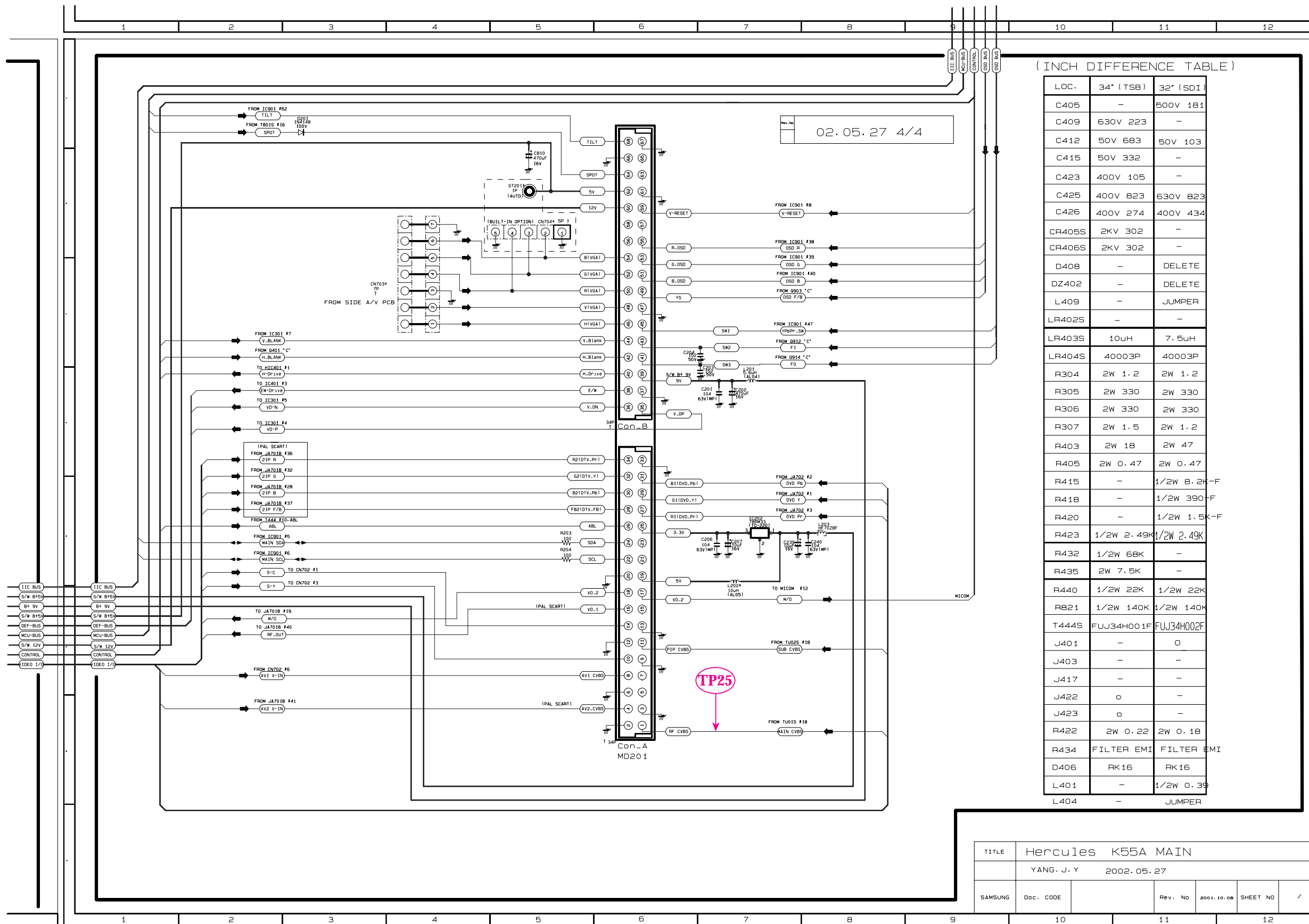

(INCH DIFFERENCE TABLE)

LOC.	34" (TSB)	32" (SDI)
C405	-	500V 181
C409	630V 223	-
C412	50V 683	50V 103
C415	50V 332	-
C423	400V 105	-
C425	400V 823	630V 823
C426	400V 274	400V 434
CR405S	2KV 302	-
CR406S	2KV 302	-
D408	-	DELETE
DZ402	-	DELETE
L409	-	JUMPER
LR402S	-	-
LR403S	10uH	7.5uH
LR404S	40003P	40003P
R304	2W 1.2	2W 1.2
R305	2W 330	2W 330
R306	2W 330	2W 330
R307	2W 1.5	2W 1.2
R403	2W 18	2W 47
R405	2W 0.47	2W 0.47
R415	-	1/2W 8.2K-F
R418	-	1/2W 390-F
R420	-	1/2W 1.5K-F
R423	1/2W 2.49K	1/2W 2.49K
R432	1/2W 68K	-
R435	2W 7.5K	-
R440	1/2W 22K	1/2W 22K
R821	1/2W 140K	1/2W 140K
T444S	FUJ34H001F	FUJ34H002F
J401	-	0
J403	-	-
J422	0	-
J423	0	-
R422	2W 0.22	2W 0.18
R434	FILTER EMI	FILTER EMI
D406	RK16	RK16
L401	-	1/2W 0.39
L404	-	JUMPER

TITLE	Hercules K55A MAIN				
	YANG, J. Y 2002.05.27				
SAMSUNG	Doc. CODE		Rev. No	2001.10.08	SHEET NO /

9-5 MICOM

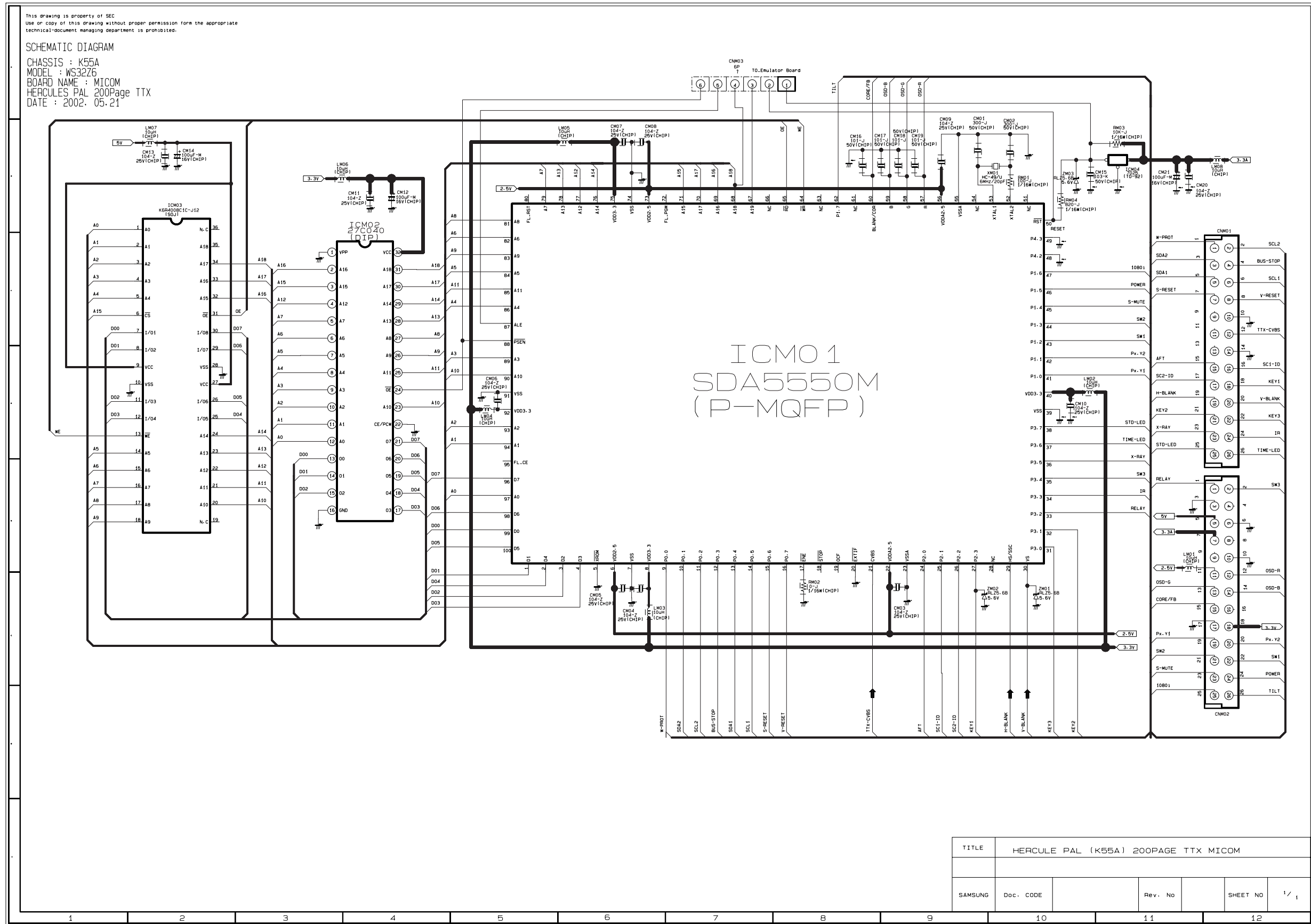

9-6 CRT

This drawing is property of SEC  
Use or copy of this drawing without proper permission from the appropriate  
technical-document managing department is prohibited.

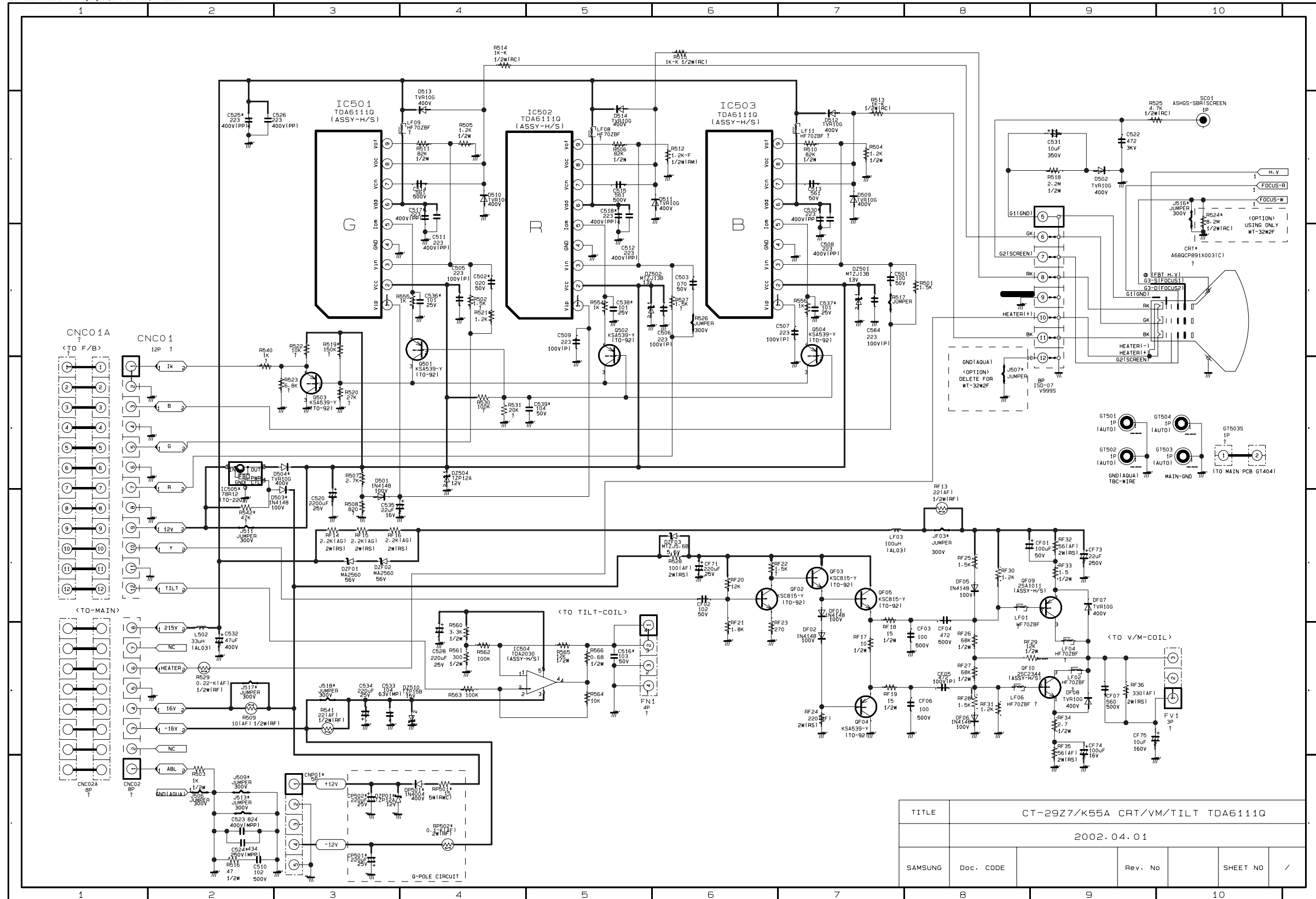

# 9-7 F-BOX 1

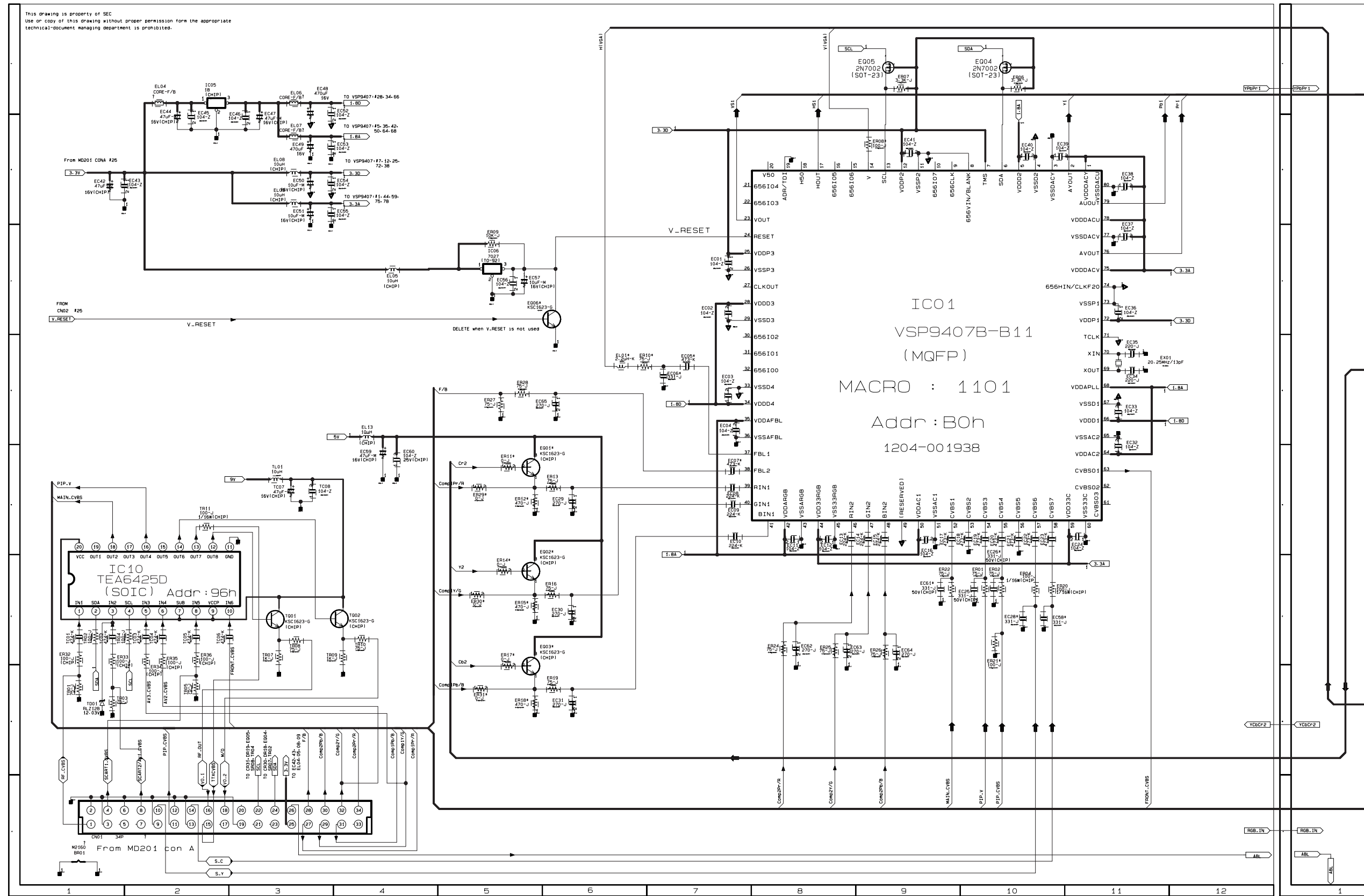

9-8 F-BOX 2

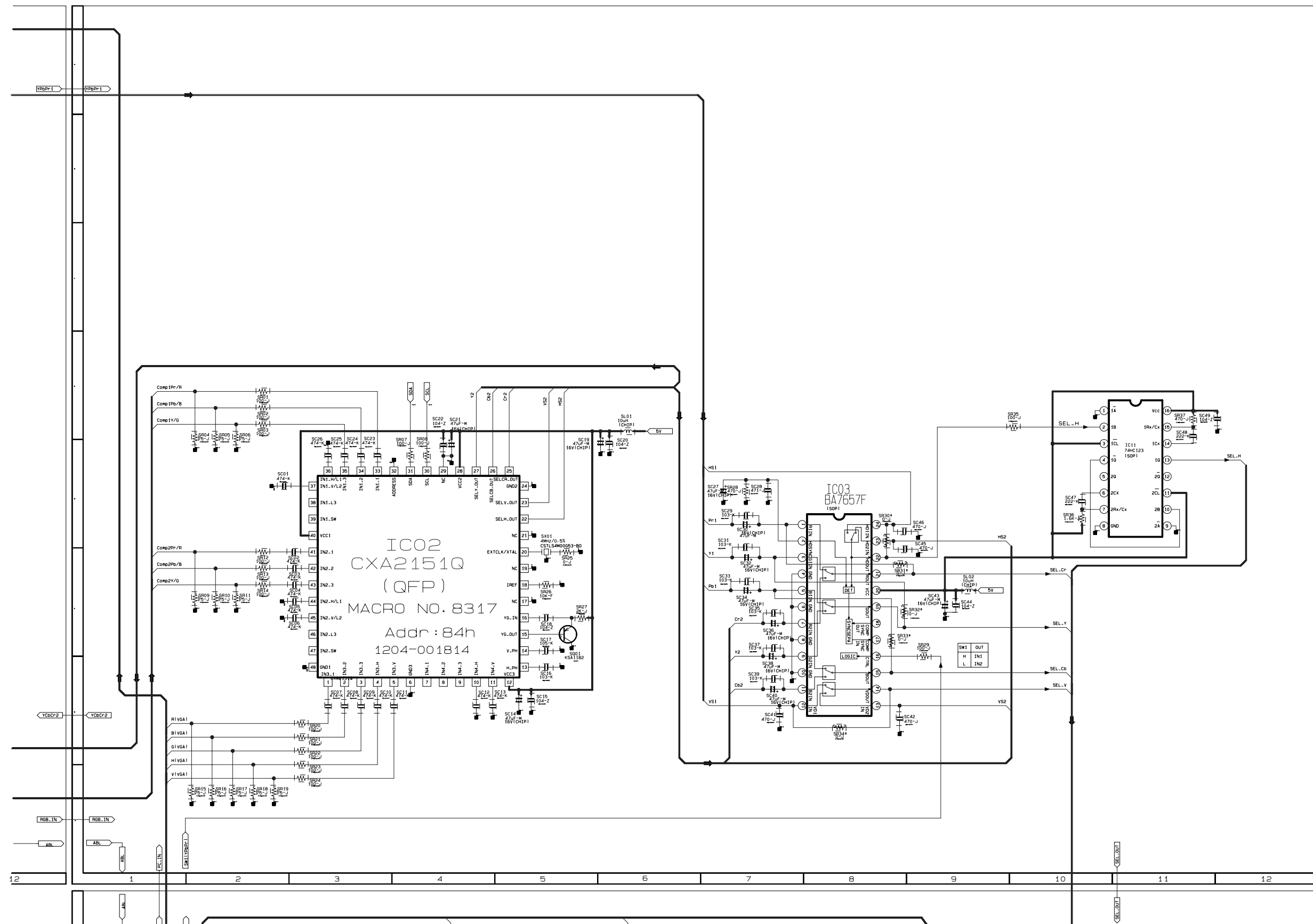

9-9 F-BOX 3

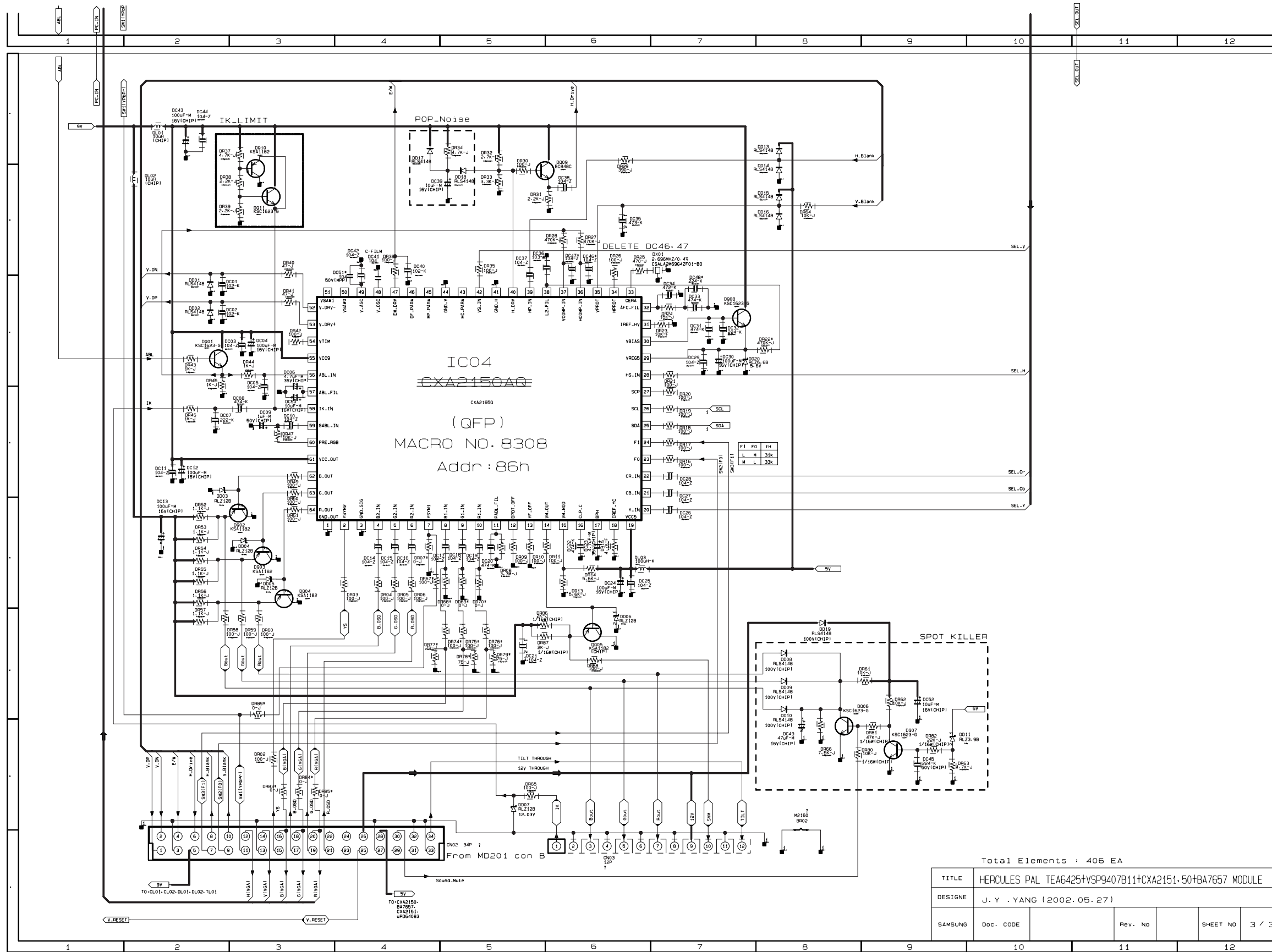

Total Elements : 406 EA

TITLE	HERCULES PAL TEA6425+VSP9407B11+CXA2151.50+BA7657 MODULE				
DESIGNE	J. Y . YANG (2002.05.27)				
SAMSUNG	Doc. CODE	Rev. No	SHEET NO	3 / 3	

# 9-10 CONTROL

This drawing is property of SEC  
 Use or copy of this drawing without proper permission from the appropriate  
 technical-document managing department is prohibited.

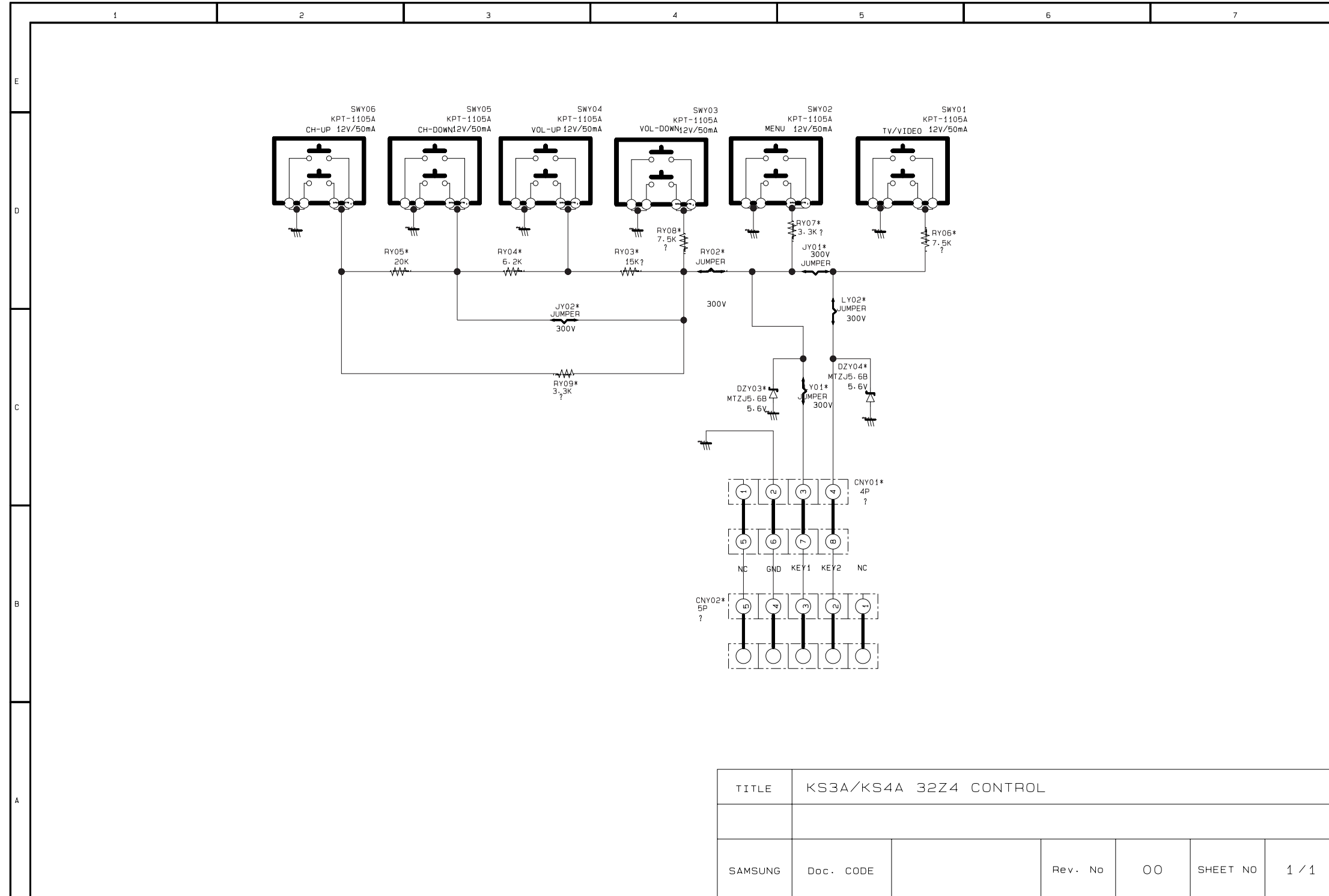



9-11 A/V SIDE

This drawing is property of SEC  
Use or copy of this drawing without proper permission from the appropriate  
technical-document managing department is prohibited.

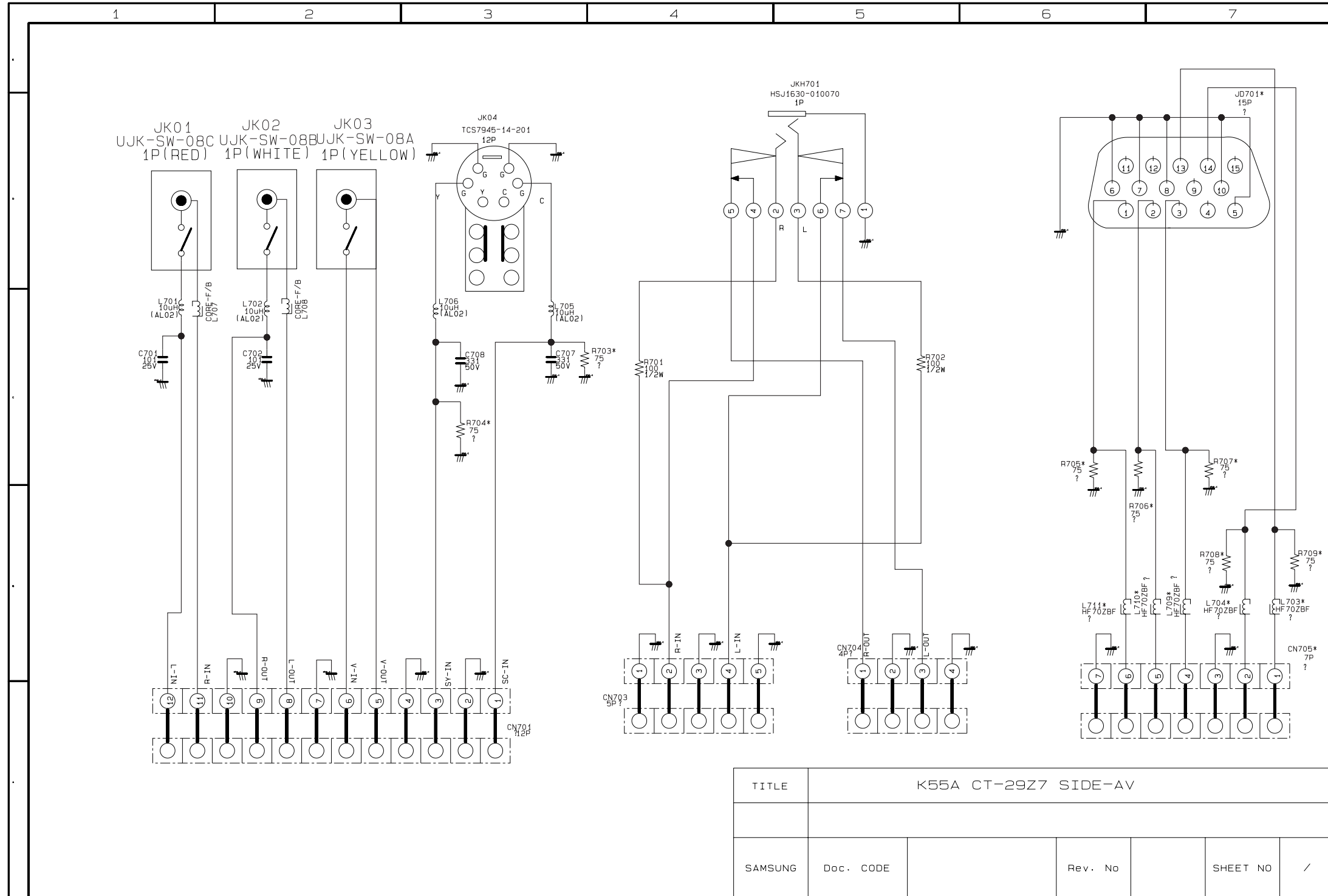

TITLE	K55A CT-29Z7 SIDE-AV					
SAMSUNG	Doc. CODE		Rev. No	SHEET NO	/	

9-12 LED

This drawing is property of SEC  
 Use or copy of this drawing without proper permission from the appropriate  
 technical-document managing department is prohibited.

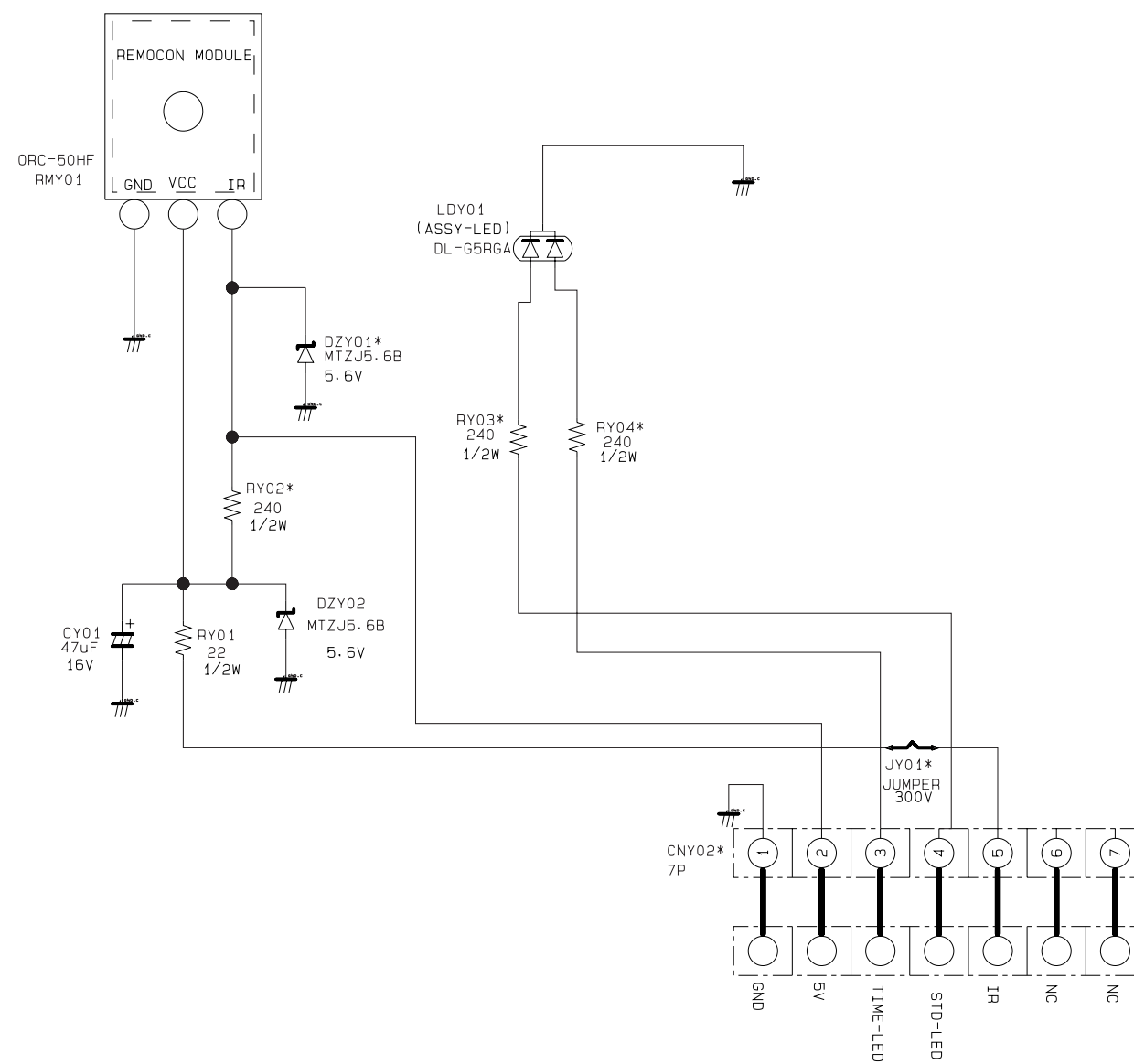

TITLE	AMADEUS LED MODULE					
SAMSUNG	Doc. CODE		Rev. No	00	SHEET NO	1 / 1

1 2 3 4 5 6