

# **SERVICE MANUAL**

Color Television Receiver

Model: -SZ2 (MONO) series

## SPECIFICATION

System	TV PAL D/K , B/G , I AV NTSC 4.43/3.58MHz
Channel	VHF LOW 49.75~85.25 MHz VHF HIGH 168.25~216.25MHz UHF 471.25~863.25 MHz CATV 112.25~464.25MHz
Scanning	Line 625 Line Horizontal Frequency 15625Hz Vertical 50/60 Hz
IF Frequency	Video 38MHz Sound 31.5/32/32.5 MHz Chroma 33.57 MHz
Sensitivity	VHF LOW 43 dB $\mu$ V VHF HIGH 45 dB $\mu$ V UHF 45 dB $\mu$ V CATV 45 dB $\mu$ V
Audio Output Power	7% THD 2W + 2W
Antenna Impedance	75 $\Omega$
Power Consumption	60W (14" series) 75W (21" series)
Power Supply	AC 110/220/240V 50/60Hz

## IMPORTANT SERVICE SAFETY INFORMATION

Operating the receiver outside of its cabinet or with its back removed involves a shock hazard. Work on these models should only be performed by those who are thoroughly familiar with precautions necessary when working on high voltage equipment.

Exercise care when servicing this chassis with power applied. Many B plus and high voltage RF terminals are exposed which, if carelessly contacted, can cause serious shock or result in damage to the chassis. Maintain interconnecting ground lead connections between chassis, escutcheon, picture tube dag and tuner when operating chassis.

These receivers have a "polarized" AC line cord. The AC plug is designed to fit into standard AC outlets in one direction only. The wide blade connects to the 'ground side' and the narrow blade connects to the 'hot side' of the AC line. This assures that the TV receiver is properly grounded to the house wiring. If an extension cord must be used, make sure it is of the 'polarized' type.

Since the chassis of this receive is connected to one side of the AC supply during operation, service should not be attempted by anyone not familiar with the precautions necessary when working on these types of equipment.

When it is necessary to make measurements or tests with AC power applied to the receiver chassis, an Isolation Transformer must be used as a safety precaution and to prevent possible damage to transistors. The Isolation Transformer should be connected between the TV line cord plug and the AC power outlet.

Certain HV failures can increase X-ray radiation. Receivers should not be operated with HV levels exceeding the specified rating for their chassis type. The maximum operating HV specified for the chassis used in these receivers is  $23.5\text{kV} \pm 1.0\text{kV}$  at zero beam current with a liner voltage of 120V AC. Higher voltage may also increase the possibility of failure in the HV supply.

It is important to maintain specified values of all components in the horizontal and high voltage circuits and anywhere else in the received that could cause a rise in high voltage, or operating supply voltages. No changes should be made to the original design of the receiver.

Components shown in the shaded areas on the schematic diagram and/or identified by in the replacement parts list should be replaced only with exact factory recommended replacement parts. The use of unauthorized substitute parts man creates may create shock, fire, X-ray radiation, or other hazards.

To determine the presence of high voltage, use accurate high impedance HV meter connected between the second anode lead and the CRT dag grounding device. When servicing the High Voltage System remove static charges from it by connecting a 10K Ohm resistor in series with an insulated wire (such as test probe) between the picture tube dag and 2nd anode lead (Have AC line cord disconnected from AC supply).

The picture tube used in this receiver employ integral implosion protection. Replace with a tube of the same type number for continued safety. Do not lift picture tube by the neck. Handle the picture tube only when wearing shatterproof goggles and after discharging the high voltage completely. Keep others without shatter proof goggles away.

Before returning the receiver to the user, perform the following safety checks:

1. Inspect all lead dress to make certain that leads are not pinched or that hardware is not lodged between the chassis and other metal parts in the receiver.
2. Replace all protective devices such as non-metallic control knobs, insulating fishpapers, cabinet backs, adjustment and compartment covers of shields, isolation resistor-capacitor networks, mechanical insulators etc.
3. To be sure that not shock hazard exists, a check for the presence of leakage current should be made at each exposed metal part having a return path to the chassis (antenna, cabinet metal, screw heads knobs and/or shafts, escutcheon, etc.) in the following manner.

Plug the AC line cord directly into a 110V/220V/240V, AC receptacle. (Do not use an Isolation Transformer during these checks.) All checks must be repeated with the AC line cord plug connection reversed. (If necessary, a nonpolarized adapter plug must be used only for the purpose of completing these checks.)

If available, measure current using an accurate leakage current tester. Any reading of 0.35mA or more is excessive and indicates a potential shock hazard, which must be corrected before returning the receiver to the owner.

If a reliable leakage current tester is not available, this alternate method of measurement should be used. Using two clip leads, connect a 1500 Ohm, 10 Watt resistor paralleled by a 0.15MF capacitor in series with a known earth ground, such as a water pipe or conduit and the metal part to be checked. Use a VTVM or VOM with 1000 Ohms per Volt, or higher, sensitivity to measure this AC voltage drop across the resistor. Any reading of 0.35 Volt RMS or more is excessive and indicates potential shock hazard which must be corrected before returning the receiver to the owner.

## ALIGNMENT PROCEDURES

### PLEASE READ BEFORE ATTEMPTING SERVICE

1. Use an Isolation Transformer when performing any service on this chassis.
2. Never disconnect any leads while receiver is in operation.
3. Disconnect all power before attempting any repairs.
4. Do not short any position of the circuit while the power is on.
5. For safety reasons, replace components any with identical replacement parts (SEE PARTS LIST).
6. Before alignment, warm up the TV for at least 30 minutes and demagnetize the CRT with an external degaussing coil.
7. When removing a PCB or related component, after unfastening or changing a wire, be sure to put the wire back in its original position.
8. Inferior silicon grease can damage IC's and transistors. When replacing IC's and transistors, use only specified silicon grease. Remove all old silicon when applying new silicon.
9. Before removing the anode cap, discharge eletricity because it contains high voltage.

### Power supply

check input voltage → check voltage of C910 anode → check Pin 3 of N901 → check V901 → check output voltage of T901 secondary coil → check voltage of N904, N905 Pin 3 (5.0v) and N903 Pin 3 (9.0V) → check voltage of N103 Pin 8, 31, 32, 35, 36, 43, 55 (5v) and Pin 11, 19 (8v) → check voltage of N602 Pin 8 (+5V)

### Audio circuit

check power supply of audio power amplify circuit → check input audio signal of audio power amplify circuit → check waveform of N103 Pin 5 → check waveform of xs808 Pin 16, 17 → check waveform of N201 Pin 8, 10

### Horizontal circuit

Check voltage of T402 Pin 3 (110V) → check voltage of N103 Pin 19 (+9.0V) → check waveform of V401 Base → check waveform of V402 Collector → check output voltage of T402 coil → check waveform of T402 Pin 8

### Vertical circuit:

check voltage of N440 Pin 2 (+25V) and Pin 7 (+9V) → check voltage of N103 pin 19 (+9V) → check waveform of N103 Pin 17 → check waveform of N440 Pin 1 → check waveform of N440 Pin 5

### MCU circuit:

check voltage of N103 Pin 31, 32 (5v) → check waveform of N103 Pin 33

# ADJUSTMENT MANUAL

## 一. Test Notices:

1. Please follow the pointed test steps and choose the right test equipment to conduct adjustment, otherwise good effect of TV set could not be obtained. Pointed bias voltage value should be ensured during test to get satisfied test result.
2. To adjust the chassis, you should write master slice's data into the memory N602 which will be installed into this chassis before installing, and no any data except this test manual listed is promised to be modified without designer's agreement.
3. The unit should be warmed up 30 minutes before adjustment, and should demagnetize it with degaussing coil.

## 二. Test equipment

1. DC Power Supply(14V)
2. Oscilloscope
3. Vacuum Voltage Meter
4. Multimeter (Internal resistance:  $DC \geq 20k \Omega/V$ ,  $AC \geq 5k \Omega/V$ )
5. High Voltage Meter 30kV
6. Ammeter (0.5 grade, DC 3mA position)
7. Demagnetizing Coil
8. PHILIP Pattern Signal Generator (5820)
9. Standard Signal Generator (3216)

## 三. Factory test menu

1. Press MENU button on the remote control firstly, then the press RECALL button three times sequentially to enter FACTORY MENU.
2. Press P+ or P- button on the remote control to select test item.
3. Press V+ or V- button on the remote control to adjust the value of selected item.
4. Press RECALL button again to exit FACTORY MENU.

FACTORY MENU	00
H-PHASE	11
OSD-H-POSITION	25
V-SIZE	82
V-POSITION	1
V-LINEARRITY	22
V-SC	4
V-KILL	0
SUB-BRIGHT	85
RF-AGC AUTO	25

<b>FACTORY MENU 01</b>	
H-BLK-L	1
H-BLK-R	2
TUNER 0-3 Q Q2 A A2	0
VOL LINEAR MEASURE	1
B-Y DC LEVEL	11
R-Y DC LEVEL	10
B-Y DC LEVEL-YUV	6
R-Y DC LEVEL-YUV	6

<b>FACTORY MENU 02</b>	
RED-BIAS	117
GREEN-BIAS	134
BLUE-BIAS	153
RED-DRIVE	99
GREEN-DRIVE	10
BLUE-DRIVE	92

<b>OPTION MENU 00</b>	
BACK COVER OPTION	0
Q-ASM OPTION	0
OPT-AV-SYSTEM	0
Y-IN 0:P48 1:P54	1
OPT-YUV	0
LANGUAGE SW CE	1
ENG 0 : CH 1	0
ONLY ENG AND TAI	0

<b>OPTION MENU 01</b>	
LV1116 OPT	0
AUDIO SW	1
SIF6.5M	1
SIF6.0M	1
SIF5.5M	1
SIF4.5M	1

#### 四. Power Supply and Voltage adjustment

1. Check AC voltage is normal or not, AC220V 50Hz.
2. Receive Television broadcast signal, adjust Brightness and Contrast until the standard picture is obtained.
3. Adjust RP950 until voltage between cathode of VD950 and GND of chassis is  $110V \pm 0.5V$ . (Detail voltage please see B/M )

#### 五.High Voltage check

1. Use 220V power supply to measure that power supply is up to standard before checking the high voltage.
2. Connect the precise high voltage meter to second anode of CRT.
3. Turn on the receiver , adjust Brightness and Contrast until the standard picture is obtained and set the screen "OFF" .
4. Switch the receiver to AV,High voltage must be measured below 25kv. (Detail high voltage please see the specification of CRT.)

#### 六.Geometric Distortion and Sub-brightness adjustment

1. Receive black-white PAL five circles pattern signal, and set the picture to standard mode, apply  $80dB \mu V$  signal.
2. Enter into factory submenu FACTORY MENU 00 to adjust the following items.
3. Use P+/P- button to choose the adjustive item.
4. Use V+/V- button to adjust the parameter.

#### 七、 White balance and sub-brightness adjustment

Note: BLUE BACK must be turned off and factory menu must be ON before placing the set with aging test.

1. Set Unit to AV, and set the picture to standard mode.
2. Enter FACTORY MENU 00, press P+ or P- button to choose V-KILL, then press V+ button to display horizontal light line on the screen, adjust SCREEN potentiometer so that the horizontal light line just

displays anyone color of R,G and B, press V- button to restore the screen.

3. Input left black and right white signal for white balance adjustment.

4. Insert I<sup>2</sup>C controller plug which is used for automatic adjustment system into XS600 socket on the main board.

5. Turn on color analyzer CA100 to make zero correction.

6. Run the program (WB76810.exe t213.wbd)

7. Press "SPACE" key or press switch on the controller socket, white balance adjustment will be operated automatically. If OK, "Click" will be heard.

8. Pull out I<sup>2</sup>C controller plug from XS600, receive black-white PAL five circles pattern signal, and set the picture to standard mode. Enter FACTORY MENU 00, adjust sub-brightness until black-white gray scale is 7~7.5

#### 八、 HF AGC automatic adjustment

1. Receive signal (VHF channel)

2. Set input field strength to 60dB  $\mu$  V

3. Enter into FACTORY MENU 00, select RF AGC item, press V+ button to adjust RF AGC automatically, and when the adjustment is finished, the screen will display RF AGC value.

#### 九、 OSD position adjustment

1. Receive PAL five circles pattern signal.

2. Enter into FACTORY MENU 00 and select OSD-H-POSITION, then press V+/V- button to adjust OSD to the proper position.



# BLOCK DIAGRAM

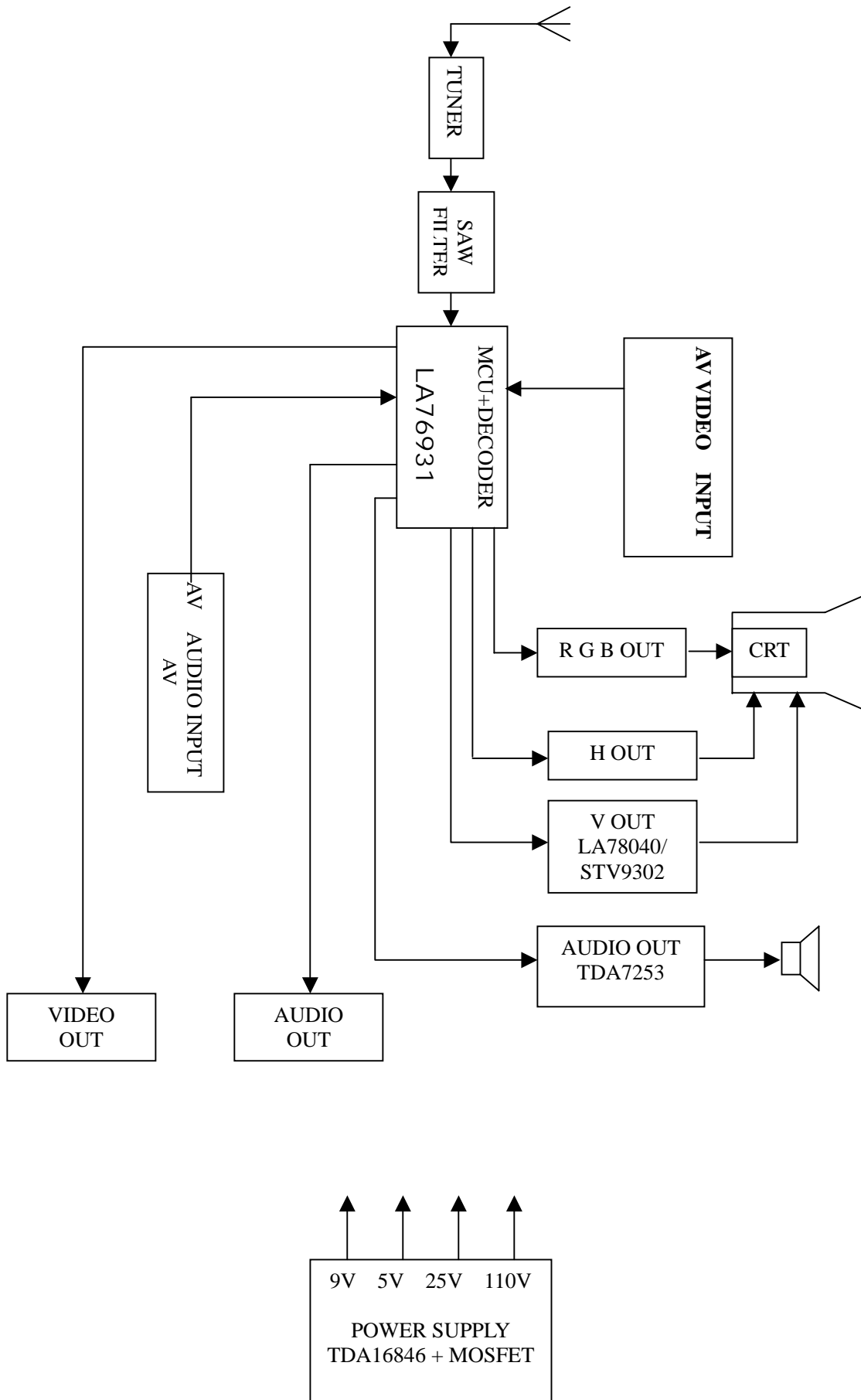

## The Technical Note of LA76931

	Function	remark
PIN 1	SIF OUTPUT	2.8V DC
PIN 2	IF AGC FILTER	
PIN 3	SIF INPUT	3.3V DC
PIN 4	FM FILTER	
PIN 5	FM OUTPUT	2.5V~3.5V
PIN 6	AUDIO OUTPUT	DC
PIN 7	SND APC FILTER	
PIN 8	IF VCC	5V DC
PIN 9	EXT AUDIO INPUT	2.9V DC
PIN 10	ABL	AUTO BEAM LIMITER
PIN 11	RGB VCC	8V DC
PIN 12	R,G,B OUTPUT	
PIN 13		
PIN 14		
PIN 15	NC	
PIN 16	V RAMP OSC.CAPACITOR	Connect 0.47uF capacitor to GND
PIN 17	VERTICAL OUTPUT	
PIN 18	VCO I REFERENCE	Connect 4.7k resister to GND
PIN 19	HORIZONTAL/BUS VCC	9V DC
PIN 20	AFC FILTER	
PIN 21	HORIZONTAL OUTPUT	
PIN 22	VIDEO CHROMA DEFLECTION GND	GND
PIN 23	NC	
PIN 24	NC	
PIN 25	SVHS CONTROL	CONTROL S OSD
PIN 26	REM	Remote control
PIN 27	AV2	Control av1/av2 input
PIN 28	AV1	
PIN 29	NC	
PIN 30	MUTE	
PIN 31	SDA	I <sup>2</sup> C control
PIN 32	SCK	I <sup>2</sup> C control
PIN 33	XT1	32.768KHz
PIN 34	XT2	32.768KHz
PIN 35	CPU VCC	5V DC
PIN 36	POWER	Control standby
PIN 37	NC	
PIN 38	AGC	

PIN 39	KEY	KEY control
PIN 40	RESET	
PIN 41	PLL	
PIN 42	CPU GND	
PIN 43	CDD VCC	5V DC
PIN 44	FBP INPUT	
PIN 45	C INPUT FOR Y/C MODE	
PIN 46	Y INPUT FOR Y/C MODE	
PIN 47	DDS FILTER	
PIN 48	Y INPUT FOR YcbCr MODE	
PIN 49	Cb INPUT for YcbCr MODE	
PIN 50	4.43MHz CRYSTAL	
PIN 51	Cr INPUT FOR YcbCr MODE	
PIN 52	SELECTED VIDEO OUTPUT OR FSC OUTPUT	
PIN 53	CHROMA APC FILTER	
PIN 54	EXT VIDEO INPUT	
PIN 55	VIDEO CHROMA DEFLECTION VCC	
PIN 56	INT VIDEO INPUT	
PIN 57	BLACK STRETCH FILTER	
PIN 58	PIF APC FILTER	
PIN 59	AFT OUTPUT	
PIN 60	VIDEO OUTPUT	
PIN 61	RF AGC OUTPUT	
PIN 62	IF GROUND	
PIN 63	PIF AMP INPUT	
PIN 64		

# The block diagrams of LA76931

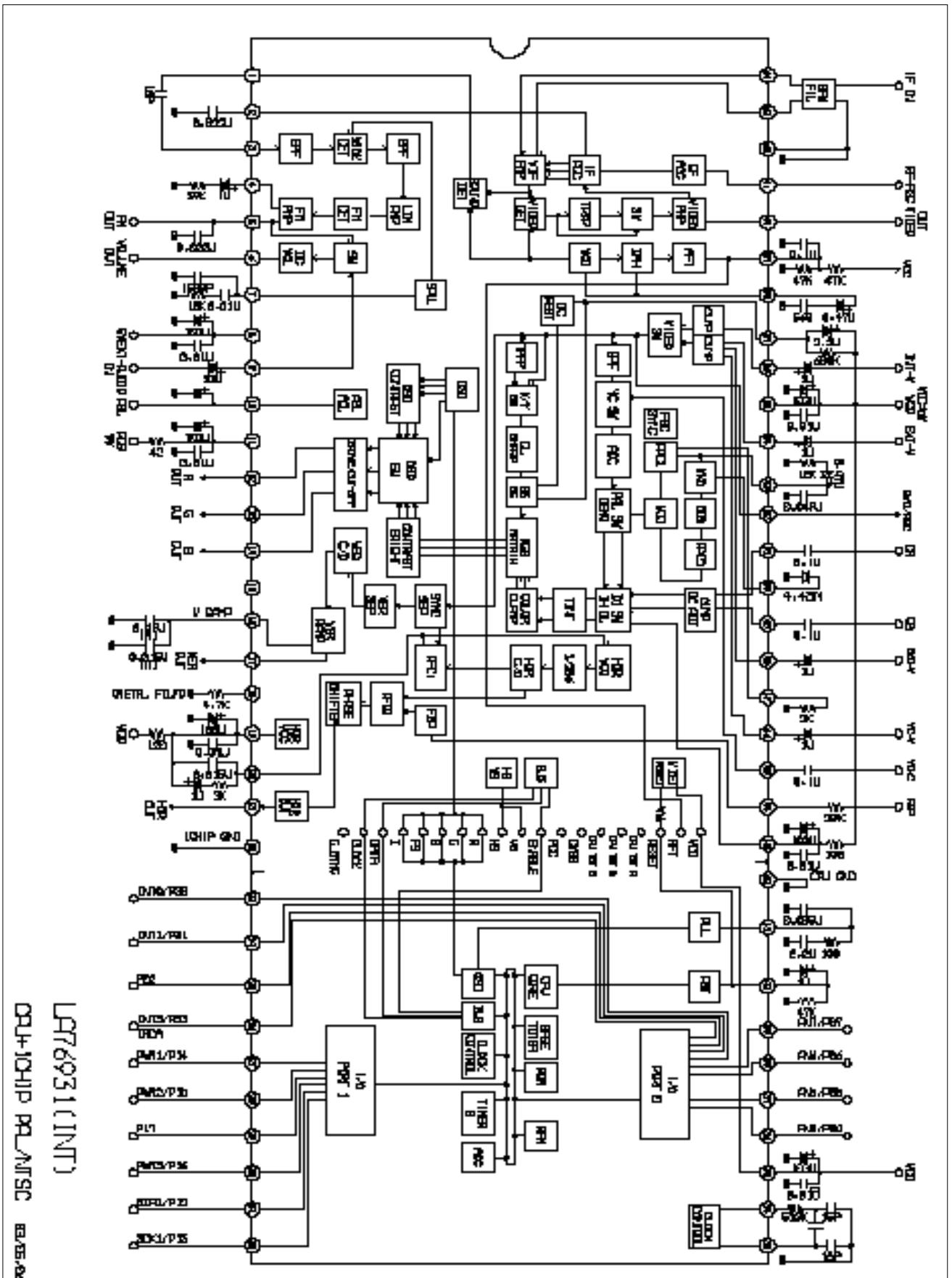

## The Technical Note of TDA16846

	Function	Remark
PIN 1	Off Time Circuit	A parallel RC-circuit between this pin and ground determines the ringing suppression time and the standby-frequency.
PIN 2	Primary Current Simulation	A capacitor between this pin and ground and a resistor between this pin and the positive terminal of the primary elcap quantifies the max. possible output power of the SMPS.
PIN 3	Regulation and Zero Crossing Input	This is the input of the error amplifier and the zero crossing input. The output of a voltage divider between the control winding and ground is connected to this input. If the pulses at pin 3 exceed a 5 V threshold, the control voltage at pin 4 is lowered.
PIN 4	Soft-Start and Regulation Capacitor	This is the pin for the control voltage. A capacitor has to be connected between this pin and ground. The value of this capacitor determines the duration of the softstart and the speed of the control.
PIN 5	Opto Coupler Input	If an opto coupler for the control is used, it's output has to be connected between this pin and ground. The voltage divider at pin 3 has then to be changed, so that the pulses at pin 3 are below 5 V.
PIN 6	Fault Comparator 2	Fault comparator 2: If a voltage > 1.2 V is applied to this pin, the SMPS stops.
PIN 7	Synchronization Input	If fixed frequency mode is wanted, a parallel RC circuit has to be connected between this pin and ground. The RC-value determines the frequency. If synchronized mode is wanted, sync pulses have to be fed into this pin.
PIN 8	Not Connected	
PIN 9	Reference Voltage and Current	Output for reference voltage (5 V). With a resistor between this pin and ground the fault comparator 2 (pin 6) is enabled.
PIN 10	Fault Comparator 1	Fault comparator 1: If a voltage > 1 V is applied to this pin, the SMPS stops.
PIN 11	Primary Voltage Check	This is the input of the primary voltage check. The voltage at the anode of the primary elcap has to be fed to this pin via a voltage divider. If the voltage of this pin falls below 1 V, the SMPS is switched off. A second function of this pin is the primary voltage dependent fold back point correction (only active in free running mode).
PIN 12	Ground	
PIN 13	Output	Output signal. This pin has to be connected across a serial resistor with the gate of the power transistor.
PIN 14	Supply Voltage	Connection for supply voltage and startup capacitor. After startup the supply voltage is produced by the control winding of the transformer and rectified by an external diode.

# The block diagrams of TDA16846



TDA 16846  
TDA 16847

## 1.5 Block Diagrams

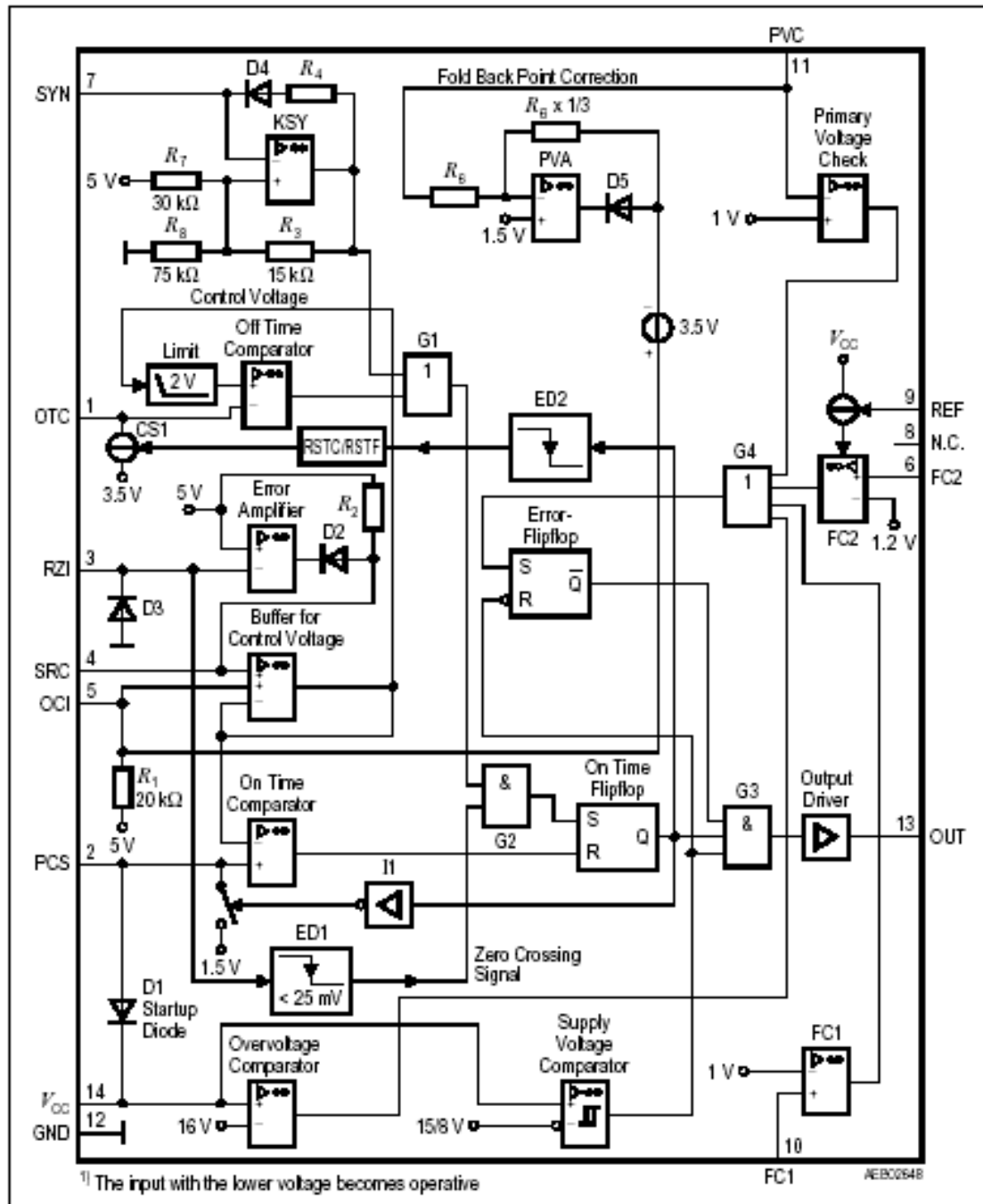
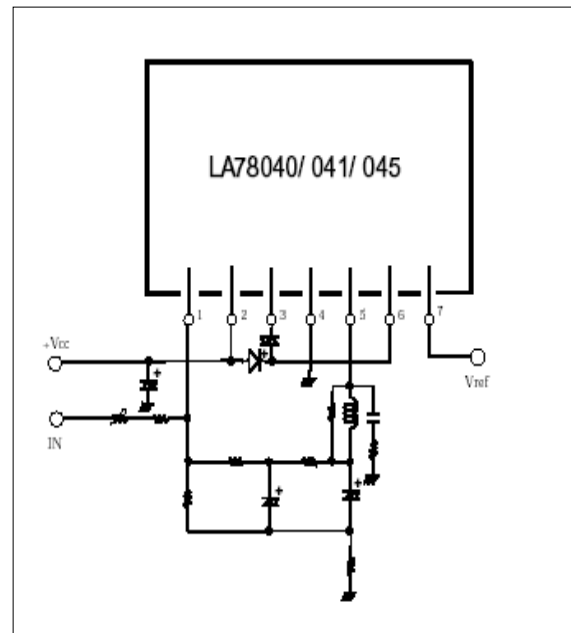
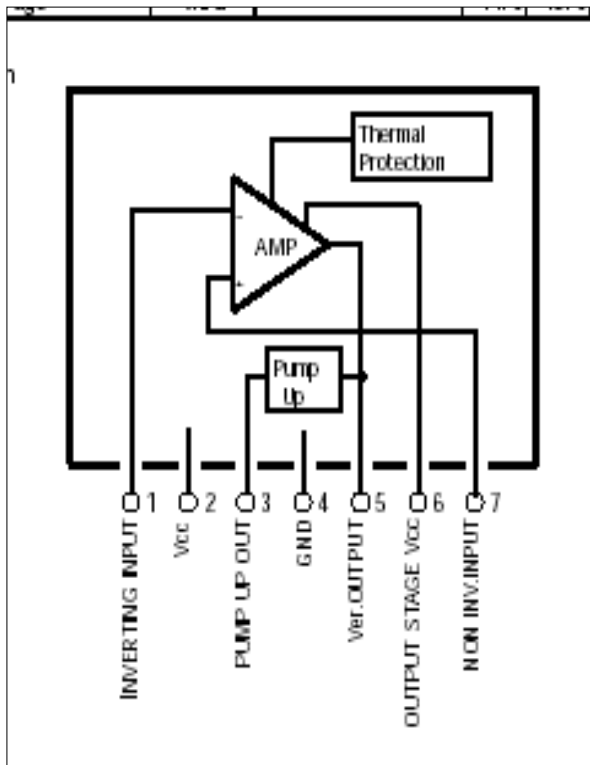

Figure 2 TDA 16846

## The Technical Note of LA78040

	Function	Remark
PIN 1	INVERTING INPUT	
PIN 2	VCC	25VDC
PIN 3	PUMP UP OUTPUT	
PIN 4	GND	
PIN 5	Ver.OUTPUT	
PIN 6	OUTPUT STAGE	
PIN 7	NON INV.INPUT	9VDC

## The block diagrams of LA78040



# The block diagrams of TDA7253

## TDA7253

### ABSOLUTE MAXIMUM RATINGS

Symbol	Parameter	Value	Unit
$V_s$	Supply Voltage	35	V
$I_o$	Output Peak Current (repetitive $f > 20\text{Hz}$ )	2.5	A
$I_o$	Output Peak Current (non repetitive, $t = 100\mu\text{s}$ )	3.5	A
$P_{tot}$	Total Power Dissipation ( $T_{case} = 70^\circ\text{C}$ )	25	W
$T_{op}$	Operating Temperature Range	0 to 70	$^\circ\text{C}$
$T_{stg, T_j}$	Storage & Junction Temperature	-40 to 150	$^\circ\text{C}$

### PIN CONNECTION (Top view)

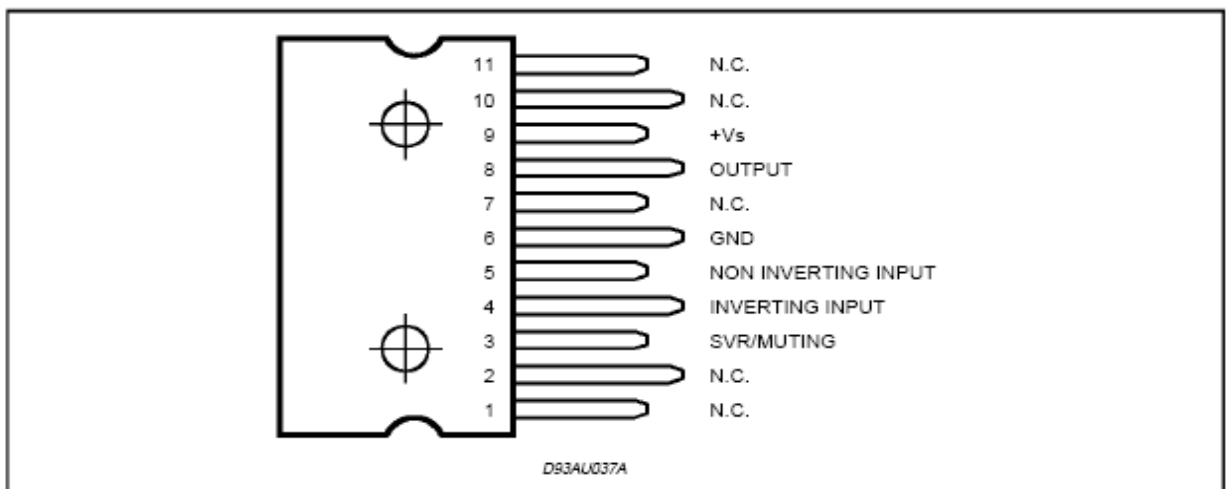
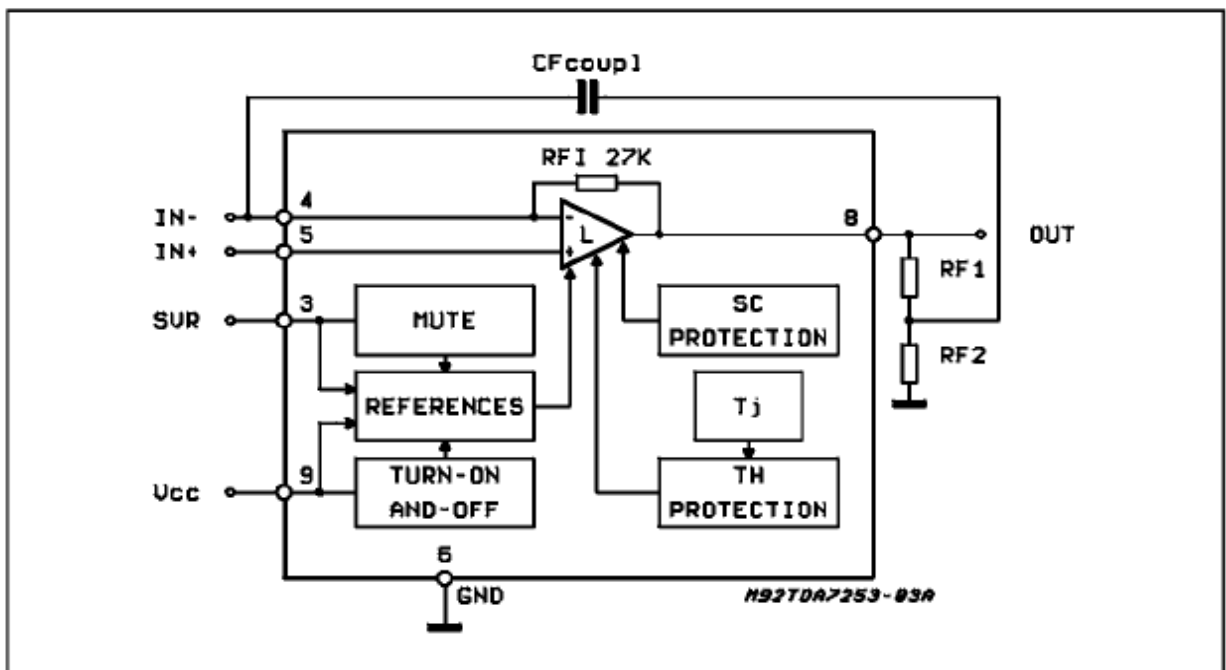

Figure 1: Application Circuit





## The Technical Note of TDA7253(8W+8W)

	Function	Remark
PIN 1	NON INVERTING INPUT(1)	
PIN 2	INVERTING INPUT(1)	
PIN 3	SVR/MUTING	
PIN 4	INVERTING INPUT(2)	
PIN 5	NON INVERTING INPUT(2)	
PIN 6	GND	
PIN 7	NC	
PIN 8	OUTPUT(2)	16 $\Omega$
PIN 9	VS	22V
PIN 10	OUTPUT(1)	16 $\Omega$
PIN 11	NC	

### THE WAVEFORM of STICKING POINT

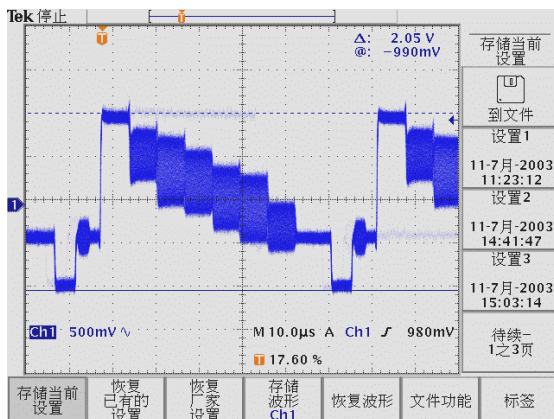

N103 PIN60 (VIDEO OUTPUT)

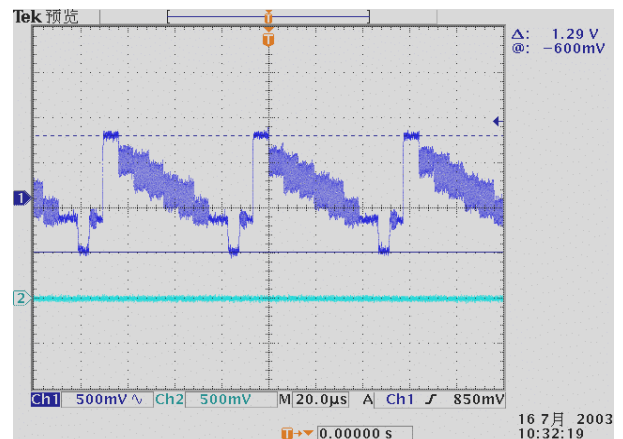

N103 PIN56(VIDEO INPUT)

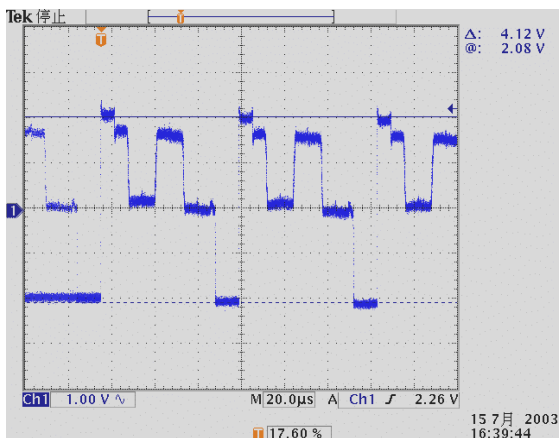

N103 PIN12 (R OUTPUT)

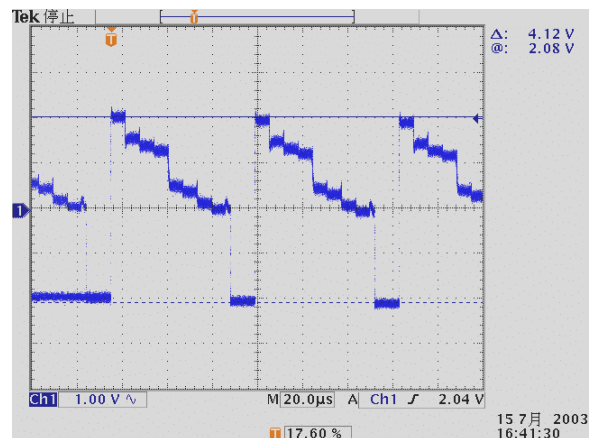

N103 PIN13 (G OUTPUT)

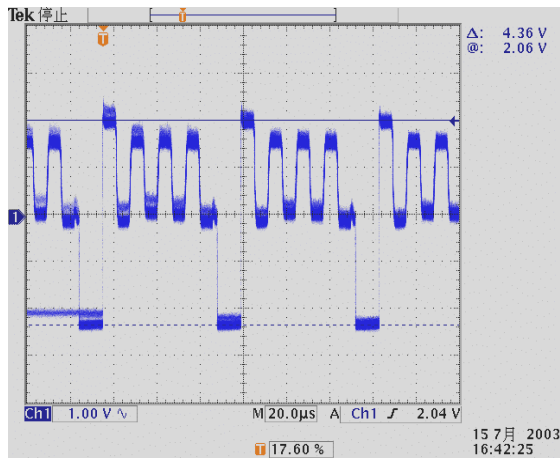

N103 PIN14 (B OUTPUT)

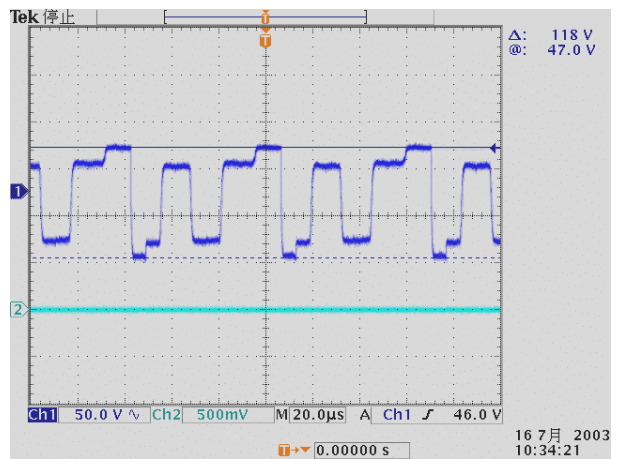

CRT ----R

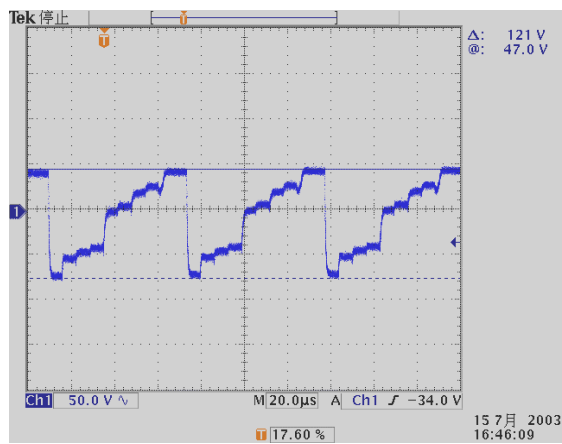

CRT-----G

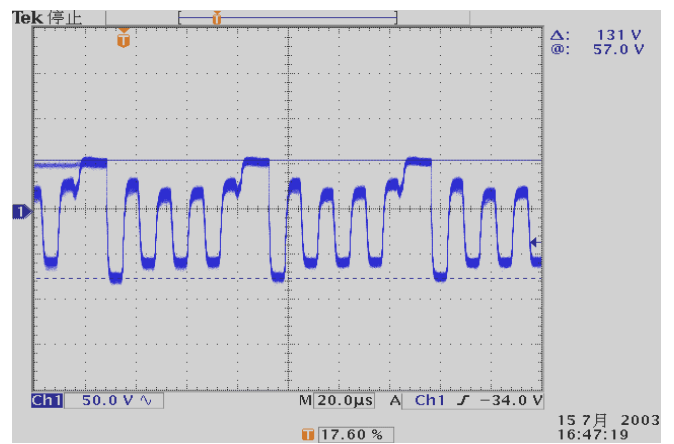

CRT -----B

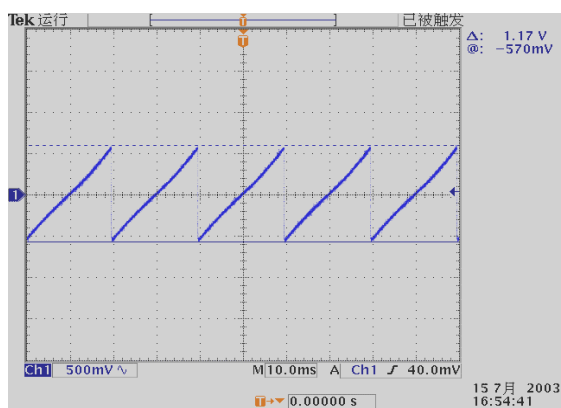

N103 PIN17 (VER OUTPUT)

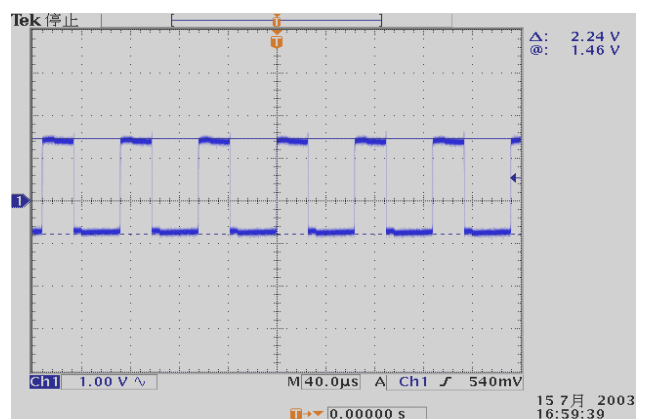

N103 PIN21 (H OUTPUT)

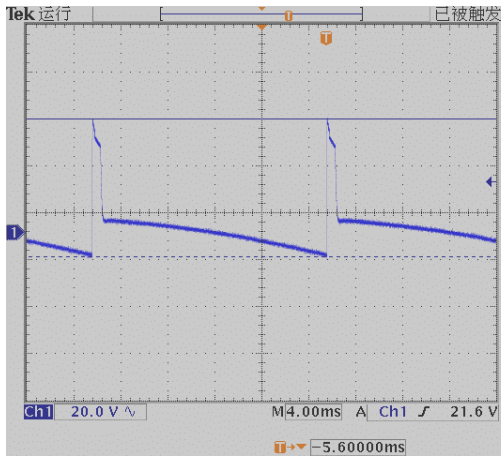

N440 PIN5 (VER OUTPUT)

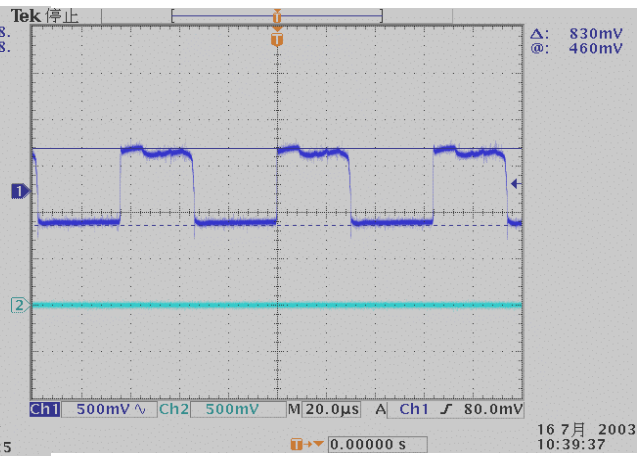

V401--B (H INPUT)

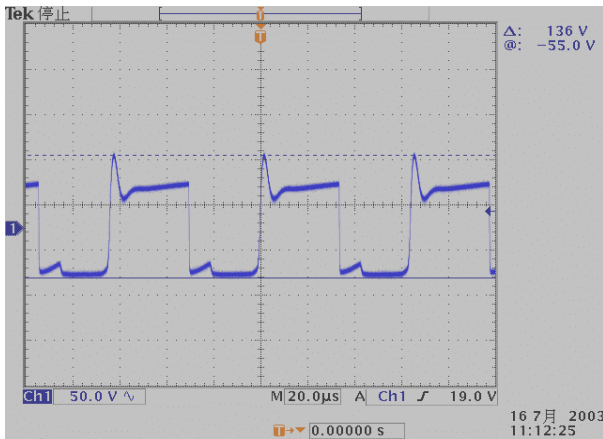

V401--C

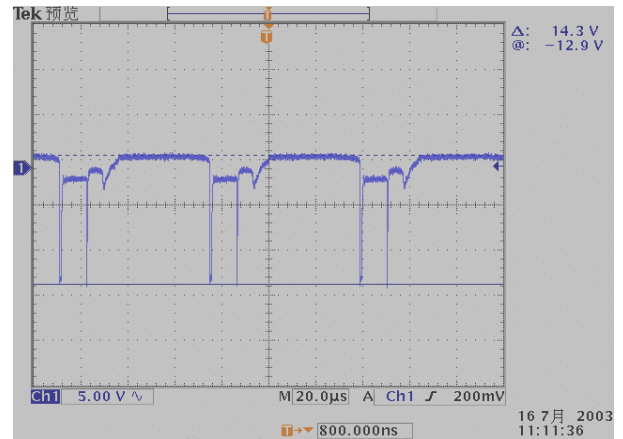

V402--B

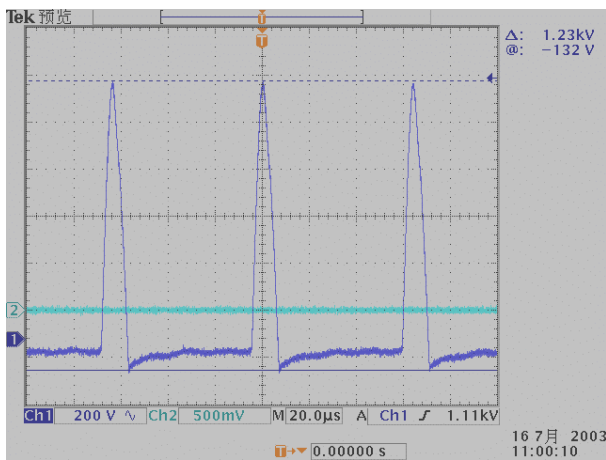

V402--C

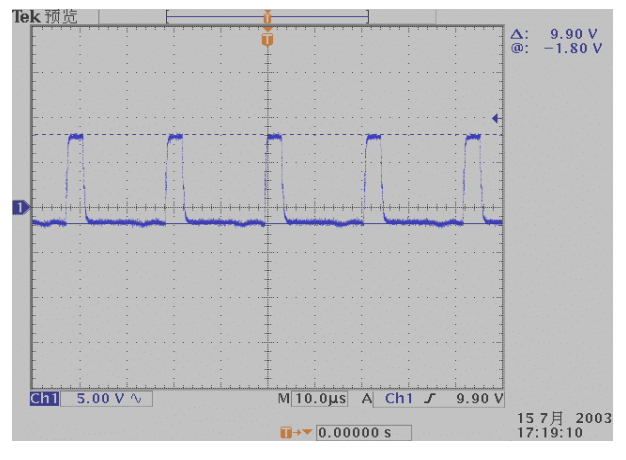

V901----G

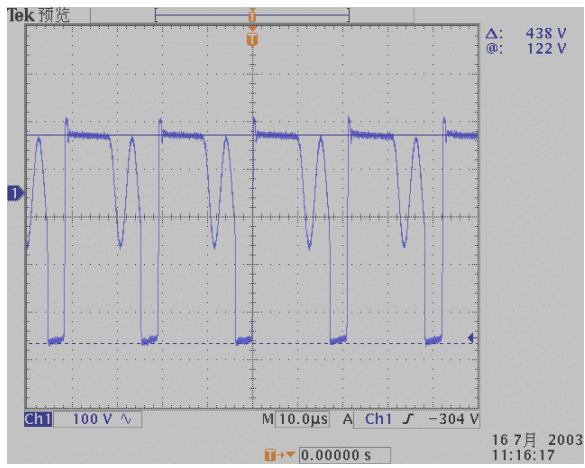

V901---S